

This file is available for free download at <http://www.iluvmyrx7.com>

This file was not scanned to deprive Mazda of any money – it was scanned due to the rareness of the original manuals and the overwhelming need of the RX-7 owner to have this information so that they can accurately troubleshoot problems. Perhaps if Mazda's dealerships could support the Rotary Engine it wouldn't be so necessary for the owners to do so.



Many thanks to Anh Diep for scanning this file.

Before beginning any service procedure, refer to the 1993 RX-7 Body Electrical Troubleshooting Manual; see section S for air bag system precautions and J1 for audio anti-theft system precautions.

# MANUAL TRANSMISSION (R15M-D)

<b>INDEX</b> .....	J - 2
<b>OUTLINE</b> .....	J - 3
SPECIFICATIONS .....	J - 3
STRUCTURAL VIEW .....	J - 3
POWERFLOW .....	J - 4
<b>TROUBLESHOOTING GUIDE</b> .....	J - 5
<b>TRANSMISSION OIL</b> .....	J - 6
INSPECTION .....	J - 6
REPLACEMENT .....	J - 6
<b>OIL SEAL (EXTENSION HOUSING)</b> .....	J - 7
PREPARATION .....	J - 7
ON-VEHICLE REPLACEMENT .....	J - 7
<b>TRANSMISSION</b> .....	J - 8
PREPARATION .....	J - 8
REMOVAL .....	J -10
DISASSEMBLY .....	J -14
INSPECTION .....	J -31
ASSEMBLY .....	J -35
INSTALLATION .....	J -57
<b>SHIFT MECHANISM</b> .....	J -61
OVERHAUL .....	J -61

**INDEX**

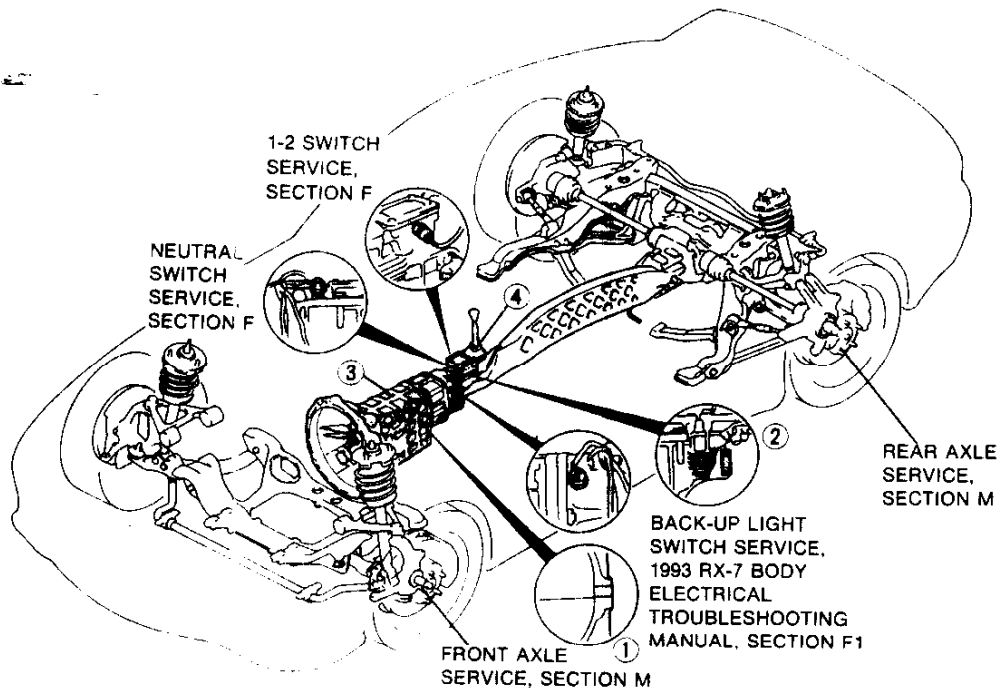

**OIL SPECIFICATION**

GRADE : API SERVICE GL-4 OR GL-5  
 ALL SEASON : SAE 75W-90  
 ABOVE 10°C (50°F) : SAE 80W-90  
 CAPACITY : 2.5 L {2.6 US qts, 2.2 Imp qts}

37U0JX-002

- |  |  |   |
|--|--|---|
| <p>1. Transmission oil<br/>             Inspection ..... page J-6<br/>             Replacement ..... page J-6</p> <p>2. Oil seal (extension housing)<br/>             On-vehicle<br/>             replacement ..... page J-7</p> | <p>3. Transmission<br/>             Removal ..... page J-10<br/>             Disassembly ..... page J-14<br/>             Inspection ..... page J-31<br/>             Assembly ..... page J-35<br/>             Installation ..... page J-57</p> | <p>4. Shift mechanism<br/>             Overhaul ..... page J-61</p> |
|--|--|---|

OUTLINE

SPECIFICATIONS

Item		Model	R15M-D (R5M-D)
Synchronization mechanism			Forward: Synchromesh Reverse: Synchromesh
Shift type			5-speed, floor shift
Shift pattern			
Gear ratio	1st		3.483
	2nd		2.015
	3rd		1.391
	4th		1.000
	5th		0.719
	Reverse		3.288
Oil	Grade		API service GL-4 or GL-5
	Viscosity	All-season	SAE 75W-90
		Above 10°C (50°F)	SAE 80W-90
	Capacity	L {US qts, Imp qts}	2.5 {2.6, 2.2}

37U0JX-003

STRUCTURAL VIEW

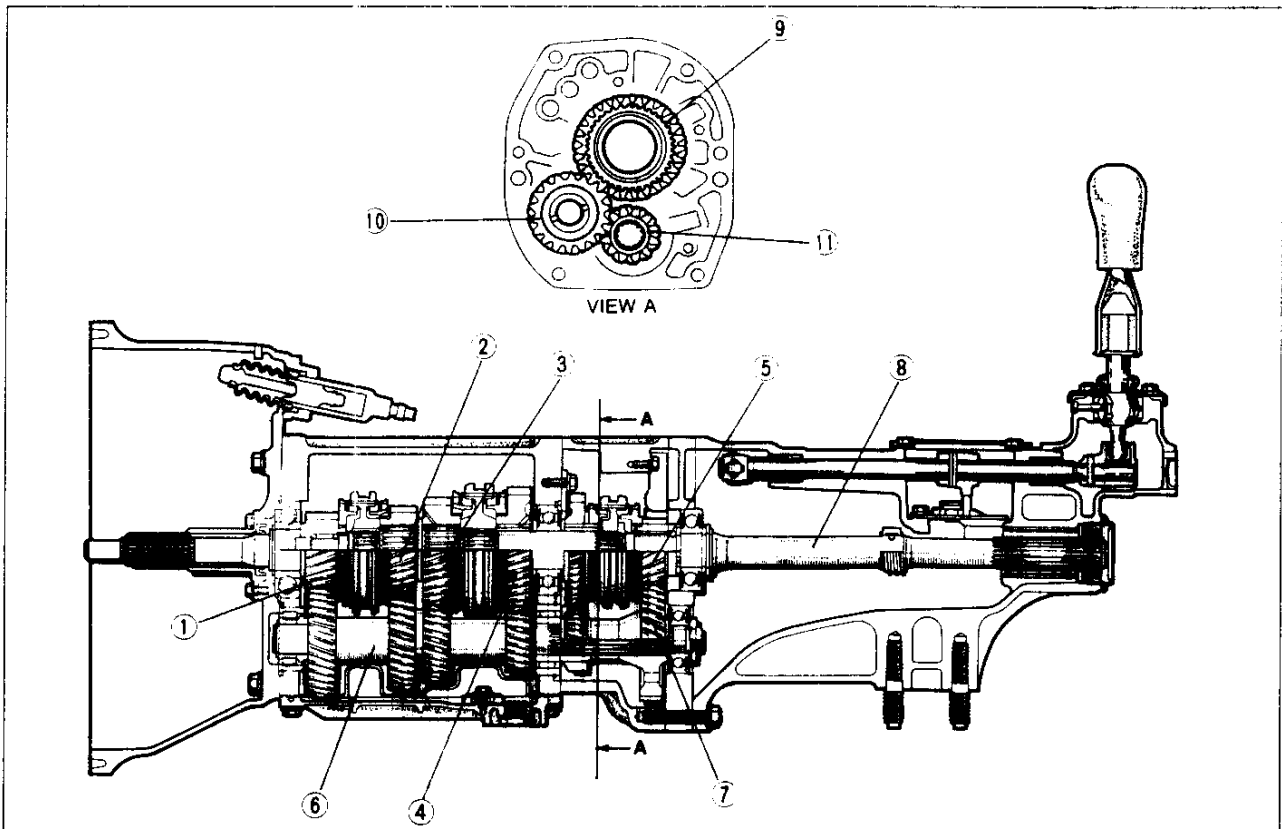

37U0JX-004

- |                               |                          |
|-------------------------------|--------------------------|
| 1. Main drive gear (4th gear) | 7. Counter 5th gear      |
| 2. 3rd gear                   | 8. Mainshaft             |
| 3. 2nd gear                   | 9. Reverse gear          |
| 4. 1st gear                   | 10. Reverse idler gear   |
| 5. 5th gear                   | 11. Counter reverse gear |
| 6. Countershaft               |                          |

POWERFLOW

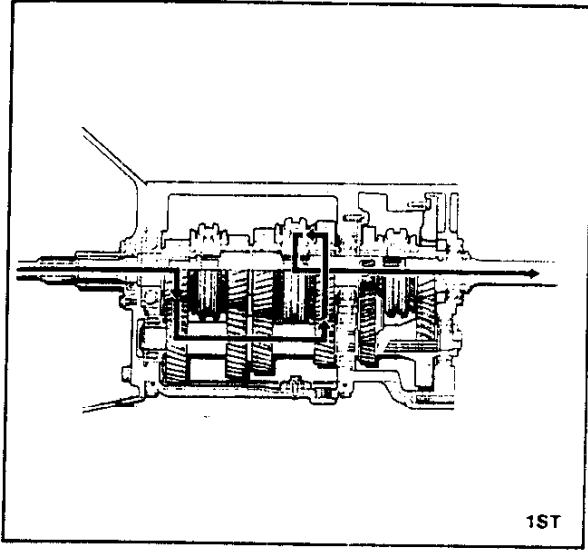

1ST

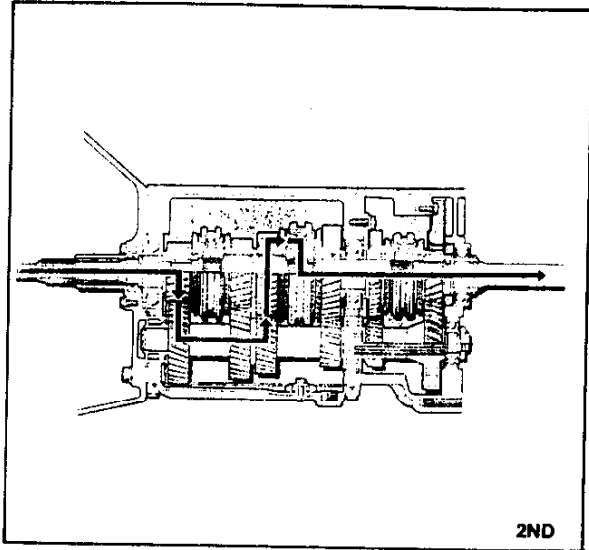

2ND

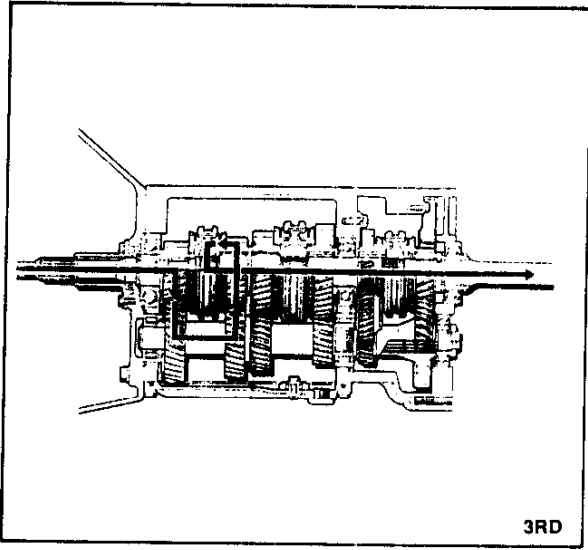

3RD

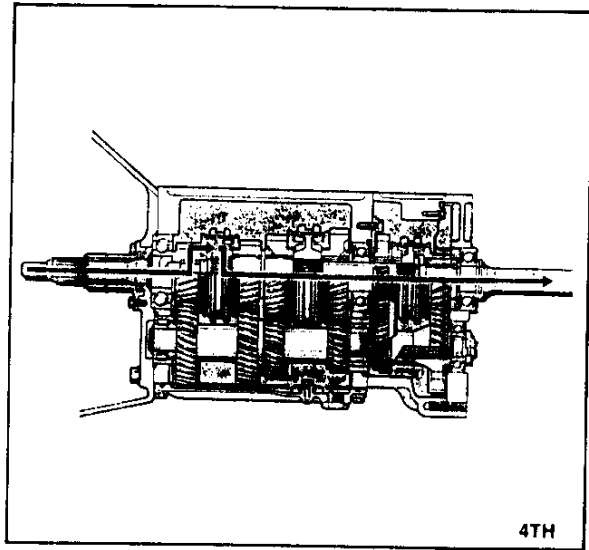

4TH

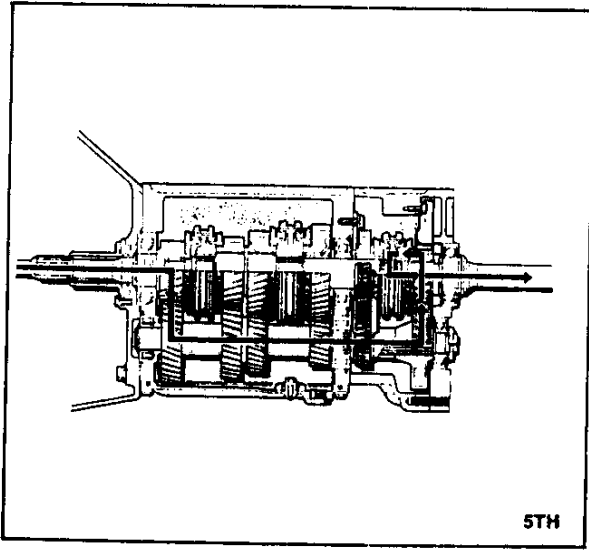

5TH

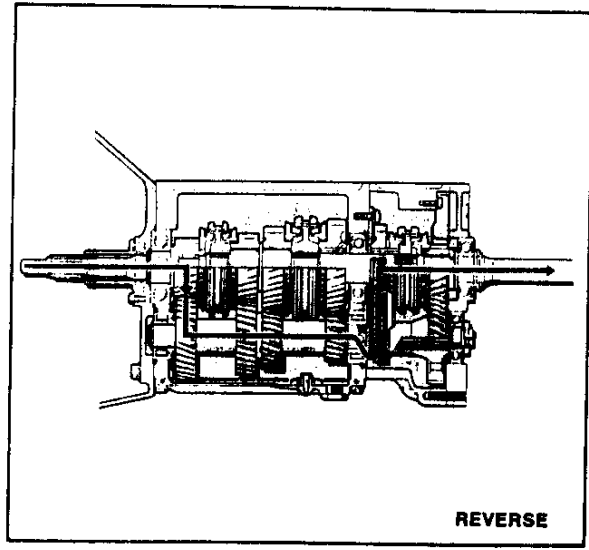

REVERSE

TROUBLESHOOTING GUIDE

Problem	Possible Cause	Action	Page
<b>Abnormal noise</b>	Insufficient oil	Add oil	J-6
	Deterioration of oil quality	Replace with specified oil	J-6
	Worn bearing	Replace	-
	Worn contact surface of countershaft gear	Replace	J-26
	Worn contact surface of gears	Replace	J-18, 22, 26
	Excessive gear backlash	Replace	J-18, 22, 26
	Damaged gear teeth	Replace	J-18, 22, 26
	Object caught in gears	Repair or replace	J-18, 22, 26
<b>Difficult to shift</b>	Bent shift rod	Replace	J-18
	Insufficient oil	Add oil	J-6
	Deterioration of oil quality	Replace with specified oil	J-6
	Wear or play of shift fork or shift rod	Replace	J-18, 22
	Worn or damaged synchronizer ring (1st, 4th, 5th, Reverse)	Replace	J-18, 26
	Worn or damaged synchronizer assembly (2nd and 3rd)	Replace	J-26
	Worn synchronizer gear cone	Replace	J-18, 22, 26
	Poor contact of synchronizer ring and gear cone	Replace	J-18, 22, 26
	Excessive longitudinal play of gears	Replace	J-18, 22, 26
	Worn bearing	Replace	-
	Improper disengagement of clutch	Refer to section H	-
Weak synchronizer key spring	Replace	J-18, 26	
<b>Jumps out of gear</b>	Weak detent ball spring	Replace	J-18
	Worn shift fork	Replace	J-18, 22
	Worn clutch hub	Replace	J-18, 26
	Worn clutch hub sleeve	Replace	J-18, 26
	Worn gears	Replace	J-18, 22, 26
	Excessive gear backlash	Replace	J-18, 22, 26
	Worn bearing	Replace	-
	Loose engine mounts or transmission mounts	Tighten	-

37U0JX-006

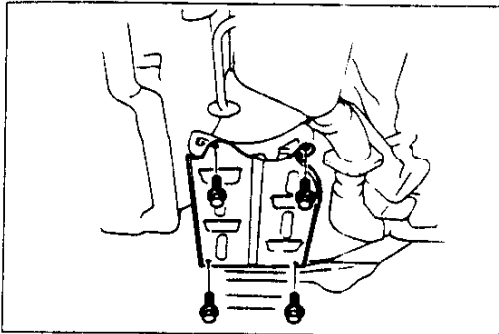

37U0JX-007

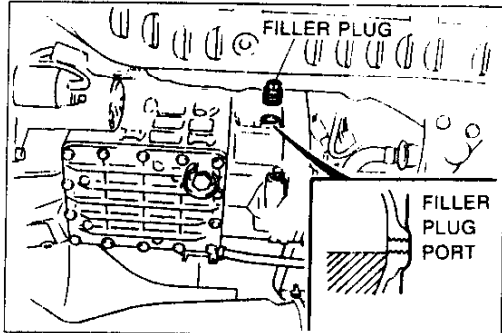

37U0JX-008

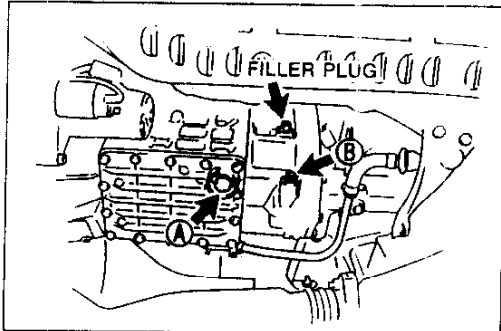

37U0JX-009

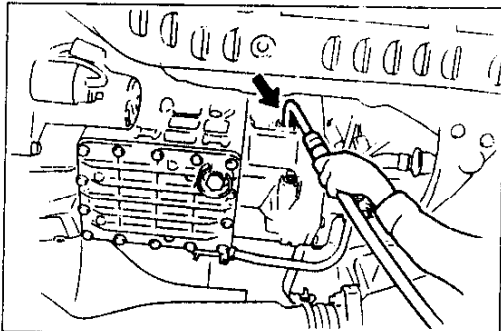

37U0JX-010

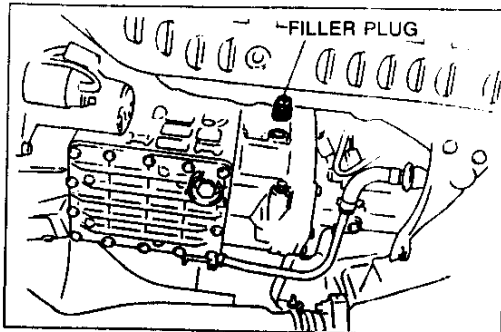

37U0JX-011

**TRANSMISSION OIL INSPECTION**

**Caution**

- Park the vehicle on level ground.

1. Remove the transmission cover.
2. Remove the filler plug.
3. Verify that the oil is up to the bottom of the filler plug hole.
4. If the oil level is low, add the specified oil through the filler plug port.
5. Install a new filler plug.

**Tightening torque:**

**25–39 N·m {2.5–4.0 kgf·m, 19–28 ft·lbf}**

6. Install the transmission cover.

**Tightening torque:**

**7.9–10.7 N·m {80–110 kgf·cm, 70–95.4 in·lbf}**

**REPLACEMENT**

1. Remove the transmission cover.
2. Remove plug A (with washer) and B, and drain the oil into a suitable container.
3. Wipe both plugs clean.
4. Apply sealant to the B plug threads.
5. Install plug A (with new washer) and B.

**Tightening torque:**

**A: 40–58 N·m {4.0–6.0 kgf·m, 29–43 ft·lbf}**

**B: 21–31 N·m {2.1–3.2 kgf·m, 16–23 ft·lbf}**

6. Remove the filler plug and add the specified oil through the filler plug port until the level rises to the bottom of the port.

**Specified oil:**

**Grade: API service GL-4 or GL-5**

**All-season: SAE 75W-90**

**Above 10°C {50°F}: SAE 80W-90**

**Capacity: 2.5 L {2.6 US qts, 2.2 Imp qts}**

7. Install a new filler plug.

**Tightening torque:**

**25–39 N·m {2.5–4.0 kgf·m, 19–28 ft·lbf}**



8. Install the transmission cover.

**Tightening torque:**

**7.9–10.7 N·m {80–110 kgf·cm, 70–95.4 in·lbf}**

OIL SEAL (EXTENSION HOUSING)

PREPARATION  
SST

<p>49 G030 795</p> <p>Installer, oil seal</p> 	<p>For ir stallation of oil seal</p>	<p>49 G030 796</p> <p>Body (Part of 49 G030 795)</p> 	<p>For ir stallation of oil seal</p>
<p>49 G030 797</p> <p>Handle (Part of 49 G030 795)</p> 	<p>For ir stallation of oil seal</p>		

37U0JX 012

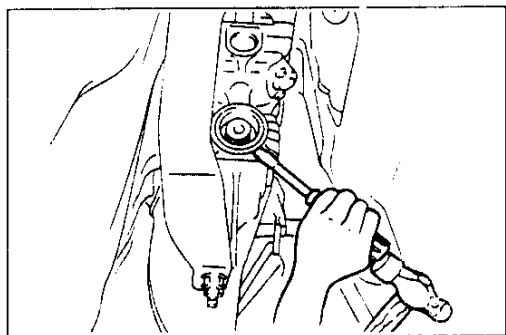

37U0JX-C13

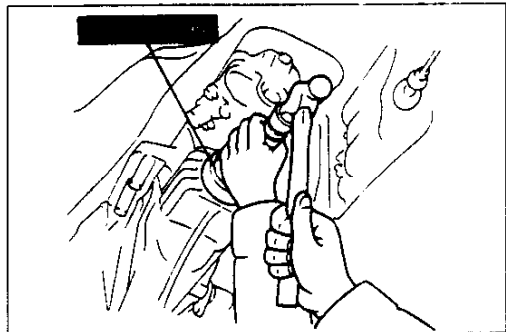

37U0JX-C14

ON-VEHICLE REPLACEMENT

Caution

- Do not damage the extension housing or mainshaft splines.

1. Remove the transmission cover.
2. Remove the propeller shaft. (Refer to section L.)
3. Remove the oil seal with a screwdriver.
4. Apply the specified oil to the new oil seal.
5. Install the oil seal by using the **SST**.
6. Install the propeller shaft. (Refer to section L.)
7. Inspect the oil level. (Refer to page J-6)
8. Install the transmission cover.

Tightening torque:









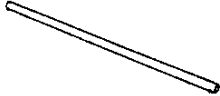

7.9-10.7 N·m {80-110 kgf·cm, 70-95.4 in·lbf}

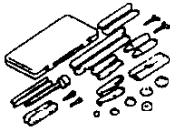

TRANSMISSION



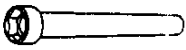
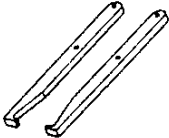
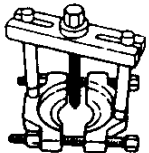
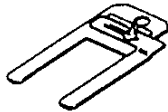

PREPARATION

SST

<p>49 G017 5A0</p> <p>Support, engine</p> 	<p>For support of engine</p>	<p>49 G017 501</p> <p>Bar (Part of 49 G017 5A0)</p> 	<p>For support of engine</p>
<p>49 G017 502</p> <p>Support (Part of 49 G017 5A0)</p> 	<p>For support of engine</p>	<p>49 G017 503</p> <p>Hook (Part of 49 G017 5A0)</p> 	<p>For support of engine</p>
<p>49 S120 440</p> <p>Holder, mainshaft</p> 	<p>For holding mainshaft</p>	<p>49 0839 425C</p> <p>Puller set, bearing</p> 	<p>For removal of bearing</p>
<p>49 G030 795</p> <p>Installer, oil seal</p> 	<p>For installation of oil seal</p>	<p>49 G030 796</p> <p>Body (Part of 49 G030 795)</p> 	<p>For installation of oil seal</p>
<p>49 G030 797</p> <p>Handle (Part of 49 G030 795)</p> 	<p>For installation of oil seal</p>	<p>49 0500 330</p> <p>Installer, transmission bearing</p> 	<p>For installation of bearing</p>
<p>49 0636 145</p> <p>Puller, fan pulley boss</p> 	<p>For removal of clutch hub assembly</p>	<p>49 0862 350</p> <p>Guide, shift fork</p> 	<p>For installation of interlock pin</p>
<p>49 1243 465A</p> <p>Wrench, mainshaft locknut</p> 	<p>For removal of locknut</p>	<p>49 H017 101</p> <p>Hook</p> 	<p>For removal of bearing</p>
<p>49 0710 520</p> <p>Puller, bearing</p> 	<p>For removal of bearing</p>	<p>49 F017 101</p> <p>Holder, synchronizer ring</p> 	<p>For installation of bearing</p>

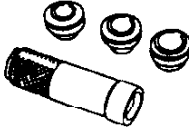
# TRANSMISSION

**J**

<p>49 F401 330B Installer set, bearing</p> 	<p>For installation of bearing</p>	<p>49 F401 331 Body (Part of 49 F401 330B)</p> 	<p>For installation of clutch hub assembly</p>
<p>49 F401 335A Attachment A (Part of 49 F401 330B)</p> 	<p>For installation of bearing race</p>	<p>49 0813 235 Replacer, main bearing</p> 	<p>For installation of main bearing</p>

37U0JX-015



**REMOVAL**

**Caution**

● **Remove the clutch release collar from the clutch cover before removing transmission.**

1. Disconnect the negative battery cable.
2. Remove in the order shown in the figure, referring to **Removal Note**.

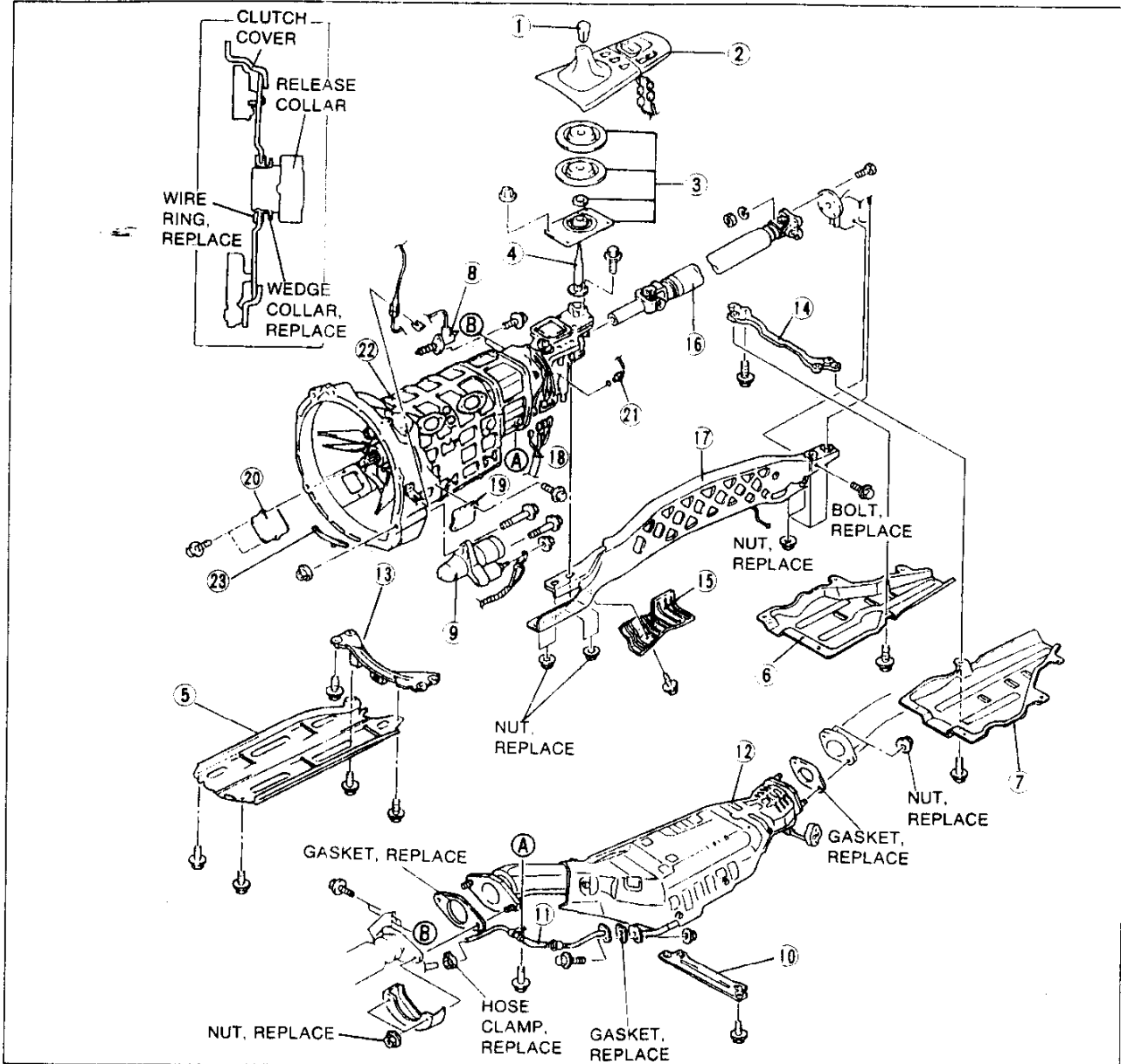

37U0JX-016

- |  |                                     |   |
|--|-------------------------------------|---|
| 1. Shift lever knob                        | 11. Secondary air injection pipe    | 17. Power Plant Frame (PPF)<br>Removal Note |
| 2. Console panel assembly                  | 12. Catalytic converter assembly    | ..... page J-11                             |
| 3. Insulator assembly                      | 13. Tunnel reinforcement (front)    | 18. Connectors                              |
| 4. Shift lever assembly                    | 14. Tunnel reinforcement (rear)     | 19. Service hole A cover                    |
| 5. Transmission cover                      | 15. Cover                           | 20. Service hole B cover                    |
| 6. Right undercover                        | 16. Propeller shaft<br>Removal Note | 21. Back-up light switch                    |
| 7. Left undercover                         | ..... page J-11                     | 22. Transmission<br>Removal Note            |
| 8. Clutch release cylinder<br>Removal Note |                                     | ..... page J-12                             |
| ..... page J-11                            |                                     | 23. Dust cover                              |
| 9. Starter                                 |                                     |   |
| 10. Tunnel reinforcement (center)          |                                     |   |

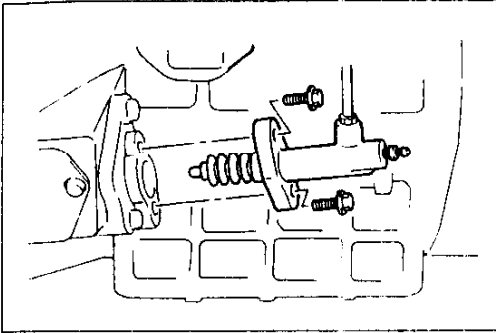

37U0JX 017

### Removal Note Clutch release cylinder

#### Caution

- Do not damage the clutch pipe.

1. Loosen the clutch release cylinder installation bolts.
2. Loosen the clutch pipe bracket bolt.
3. Secure the clutch release cylinder/clutch pipe assembly in a place where it will not interfere with transmission removal.

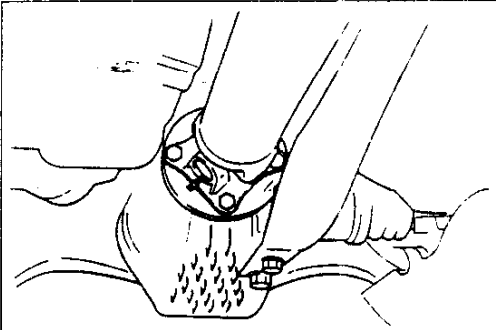

37U0JX 018

### Propeller shaft

1. Mark the flanges for correct reinstallation.
2. Remove the propeller shaft.



49 S120 440

37U0JX 019

3. Install the **SST** to the extension housing.

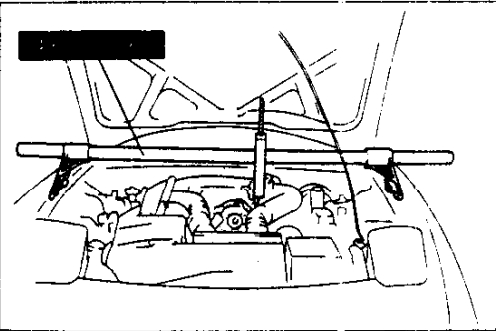

37U0JX 020

### Power plant frame (PPF)

1. Hold the engine by using the **SST** (engine supports).

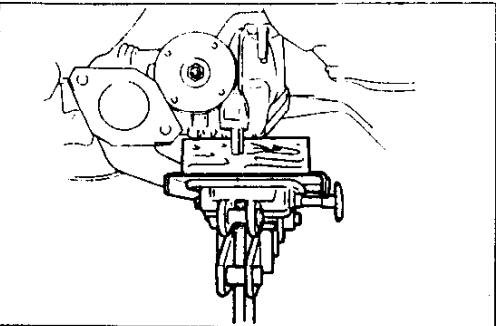

37U0JX-021

2. Hold the differential with a transmission jack.
3. Remove the PPF.
4. Remove the back-up light switch from the transmission.

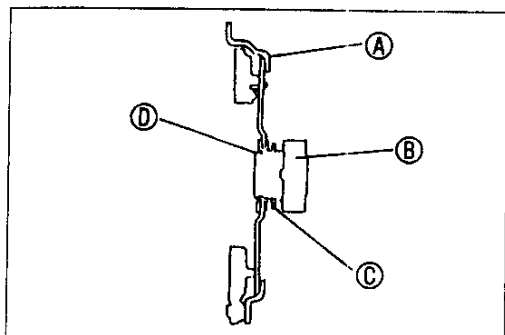

37U0JX-022

**Transmission**

1. The clutch cover and clutch release collar are joined as shown in the figure.

- A: Clutch cover
- B: Clutch release collar
- C: Wedge collar
- D: Wire ring

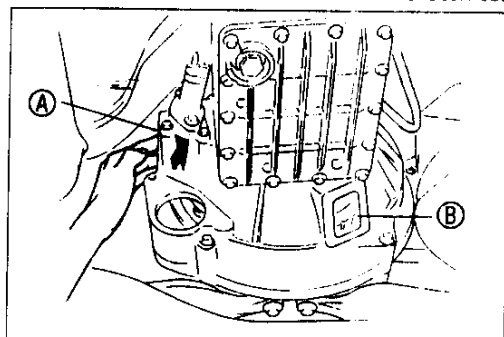

37U0JX-023

**Caution**

- Separation of the clutch cover and release collar must be done with the release collar pushed into the clutch cover, away from the transmission.
- Do not reuse wedge collar or wire ring. (Refer to section H.)

2. Remove the covers from service holes A and B.  
 3. Through service hole A, swing the release fork so that the release collar is pushed and held toward the clutch cover (engine side).

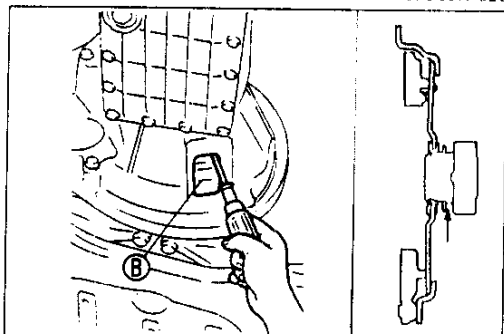

37U0JX-024

4. Insert a screwdriver through service hole B, into the space between the wedge collar and the release collar. Pry and separate the release collar from the clutch cover.

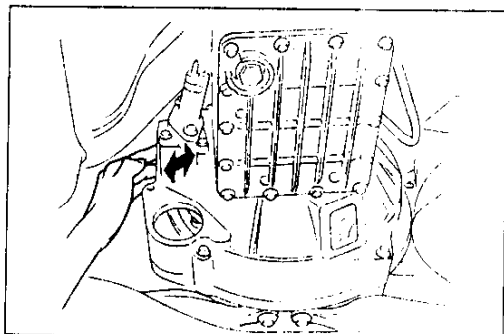

37U0JX-025

5. Swing the release fork back and forth to make sure that the release collar and clutch cover are separated.

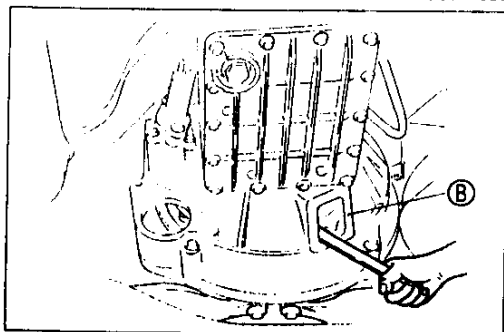

37U0JX-026

6. If the above procedure does not work, then separate the clutch cover from the flywheel, following the procedure below.

- (1) Through service hole B, gradually loosen the 6 clutch cover installation bolts in a crisscross pattern.
- (2) Remove the clutch cover installation bolts, and separate the clutch cover from the flywheel.

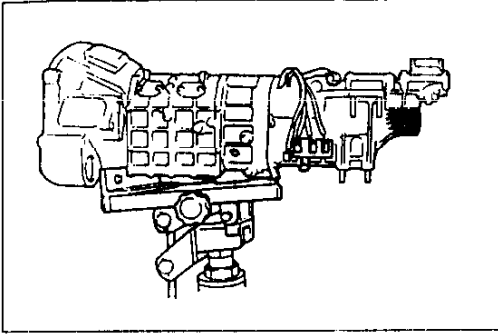

37U0JX-027

7. Support the transmission with a transmission jack.

**Warning**

- **Do not allow the transmission to fall from the jack.**

8. Loosen the transmission installation bolts.
9. Remove the transmission.

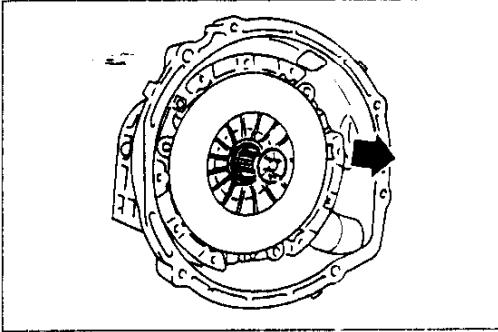

37U0JX-028

10. Remove the clutch cover.
  - (1) Remove the clutch cover from the flywheel.  
(Refer to section H.)
  - (2) If the transmission was removed by following step 6, remove the wire ring from the release collar and separate the release collar from the clutch cover.

**DISASSEMBLY****Precaution**

1. Clean the transmission exterior thoroughly with a steam cleaner or cleaning solvents before disassembly.
2. Clean the removed parts (except sealed bearings) with cleaning solvent, and dry with compressed air. Clean out all holes and passages with compressed air, and check that there are no obstructions.
3. Wear eye protection when using compressed air.
4. Use a plastic hammer when disassembling the transmission case and other light alloy metal parts.
5. Keep all disassembled parts in a clean area.
6. When using a vise, insert protective plates to prevent damage to the part.
7. Note the assembly position of each part as it is disassembled.
8. Inspect each part for damage while disassembling.

37U0JX-029

## Clutch Housing and Extension Housing Components

**Note**

- Do not remove the front and rear oil seals unless necessary.

Disassemble in the order shown in the figure, referring to **Disassembly Note**.

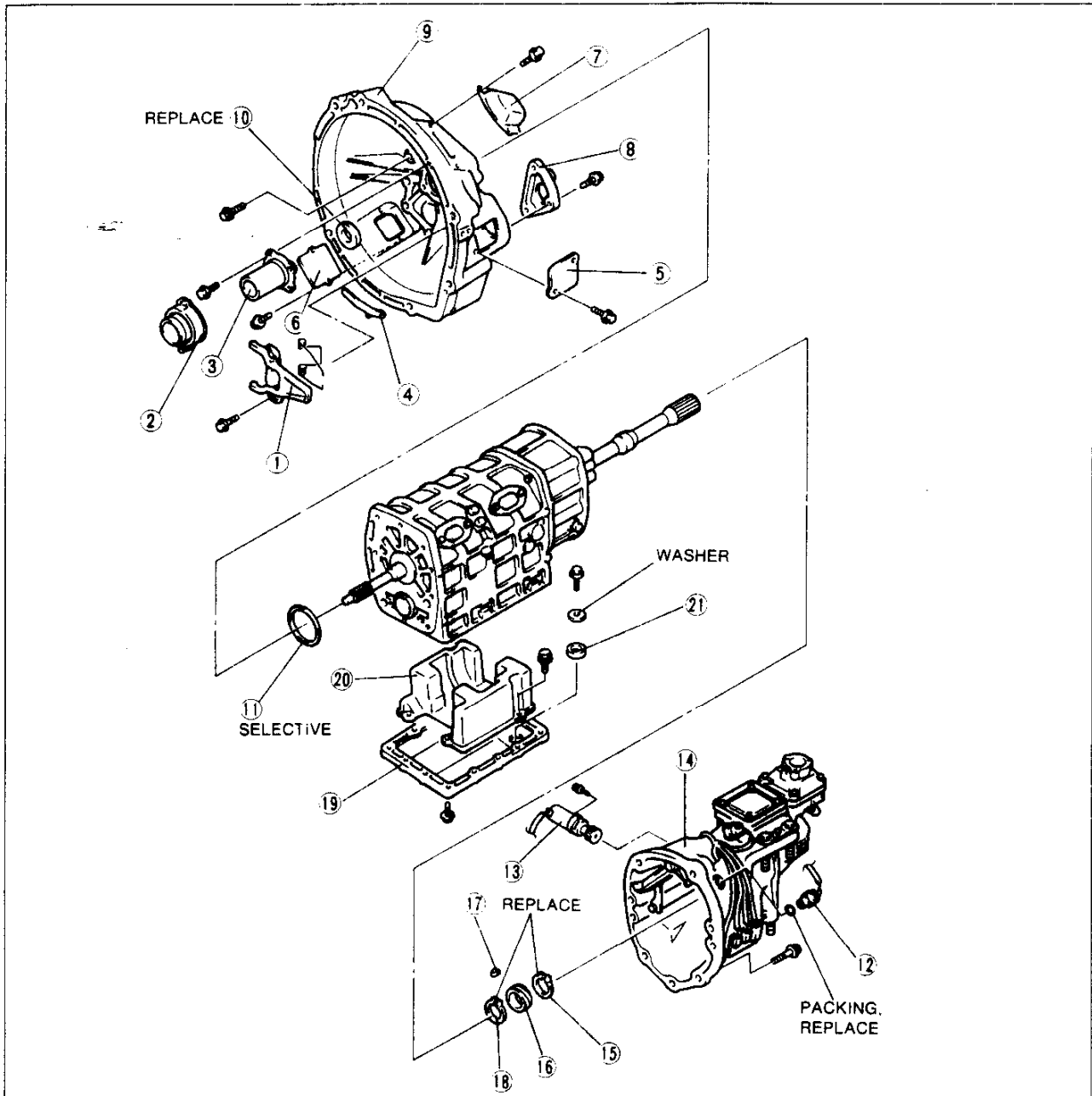

37U0JX-030

- |                             |   |                            |
|-----------------------------|---|----------------------------|
| 1. Release fork assembly    | 10. Oil seal (clutch housing)                       | 16. Speedometer drive gear |
| 2. Release collar           | 11. Adjustment shim                                 | 17. Key                    |
| 3. Front cover              | 12. Back-up light switch                            | 18. Snap ring              |
| 4. Dust cover               | 13. Speedometer sensor<br>(Speedometer driven gear) | 19. Undercover             |
| 5. Service hole A cover     | 14. Extension housing                               | 20. Oil baffle             |
| 6. Service hole B cover     | Disassembly note                                    | 21. Magnet                 |
| 7. Vent cover               | ..... page J-16                                     |                            |
| 8. Release cylinder support |   |                            |
| 9. Clutch housing           | 15. Snap ring                                       |                            |



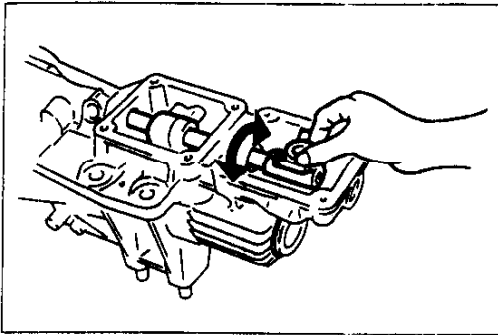

37JGJX-031

**Disassembly note  
Extension housing**

1. Move the control rod end to the neutral position.
2. Remove the extension housing installation bolts.
3. Lift up on and remove the extension housing from the center housing.

---

MEMO

5th/Reverse Gear and Housing Components

Disassemble in the order shown in the figure, referring to **Disassembly Note**.

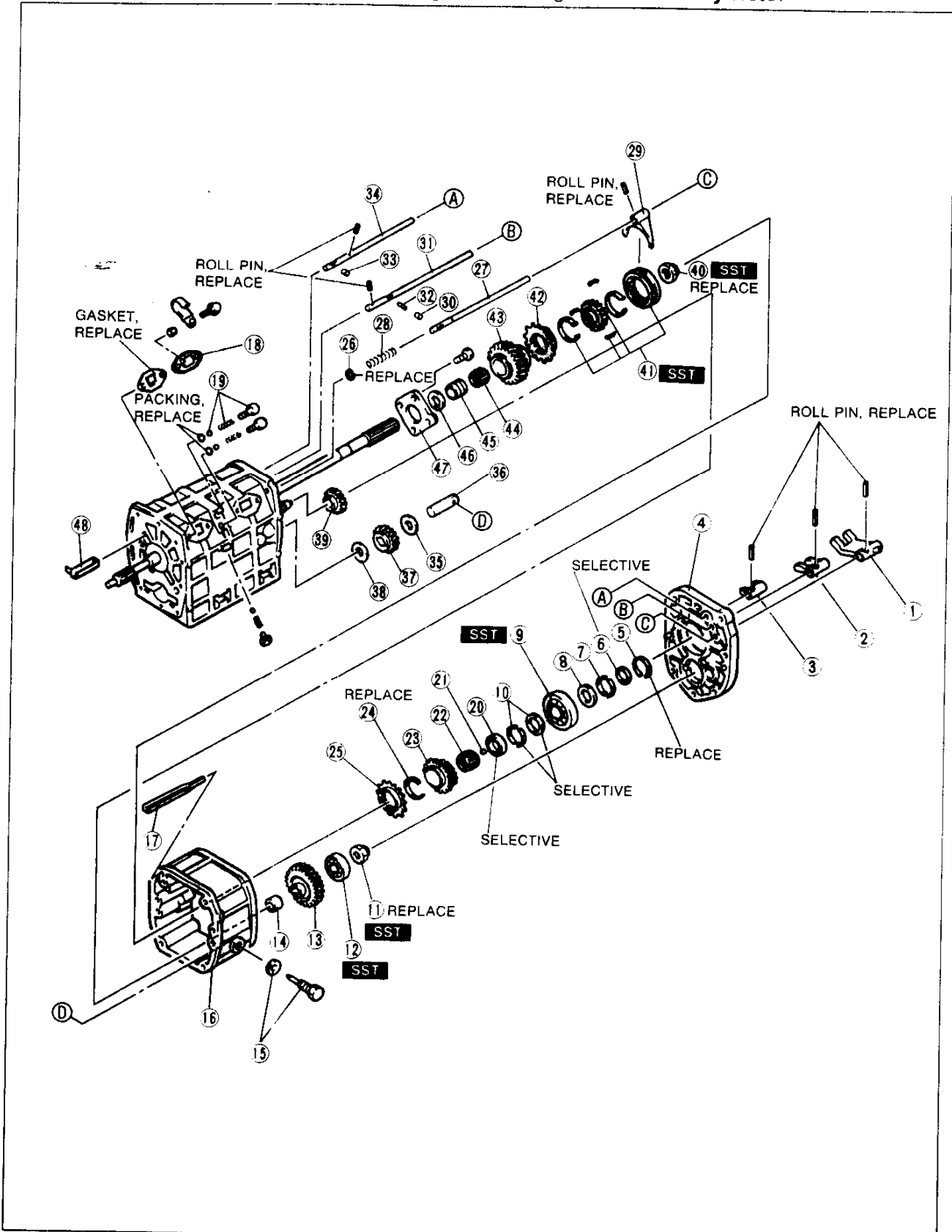

- |  |  |   |
|--|--|---|
| <p>1. 5th/Reverse shift rod end<br/>Inspection ..... page J-32</p> <p>2. 3rd/4th shift rod end<br/>Inspection ..... page J-32</p> <p>3. 1st/2nd shift rod end<br/>Inspection ..... page J-32</p> <p>4. Bearing housing<br/>Disassembly Note<br/>..... below</p> <p>5. Snap ring</p> <p>6. Thrust washer</p> <p>7. C-washers</p> <p>8. Retaining ring</p> <p>9. Mainshaft rear bearing<br/>Disassembly Note<br/>..... below<br/>Inspect for damage</p> <p>10. C-washers and retaining ring</p> <p>11. Locknut<br/>Disassembly Note<br/>..... page J-20</p> <p>12. Countershaft rear bearing<br/>Disassembly Note<br/>..... page J-20<br/>Inspect for damage</p> <p>13. Counter 5th gear<br/>Inspection ..... page J-31</p> <p>14. Spacer</p> <p>15. Set bolt and washer</p> | <p>16. Center housing<br/>Disassembly Note<br/>..... page J-20</p> <p>17. Oil guide</p> <p>18. Blind cover</p> <p>19. Cap plug, spring, and detent ball</p> <p>20. Thrust lock washer</p> <p>21. Steel ball</p> <p>22. Bearing<br/>Inspect for damage</p> <p>23. 5th gear<br/>Inspection ..... page J-31</p> <p>24. Retaining ring</p> <p>25. Synchronizer ring (5th)<br/>Inspection ..... page J-32</p> <p>26. Retaining ring</p> <p>27. 5th/Reverse shift rod<br/>Disassembly Note<br/>..... page J-20</p> <p>28. Spring<br/>Inspection ..... page J-33</p> <p>29. 5th/Reverse shift fork</p> <p>30. Interlock pin (large)</p> <p>31. 3rd/4th shift rod<br/>Disassembly Note<br/>..... page J-21</p> <p>32. Interlock pin (small)</p> <p>33. Interlock pin (large)</p> | <p>34. 1st/2nd shift rod<br/>Disassembly Note<br/>..... page J-21</p> <p>35. Thrust washer</p> <p>36. Reverse idler gear shaft<br/>Inspection ..... page J-33</p> <p>37. Reverse idler gear<br/>Inspection ..... page J-33</p> <p>38. Thrust washer</p> <p>39. Counter reverse gear<br/>Inspection ..... page J-31</p> <p>40. Locknut<br/>Disassembly Note<br/>..... page J-21</p> <p>41. 5th/Reverse clutch hub assembly<br/>Disassembly Note<br/>..... page J-21<br/>Inspection ..... page J-32</p> <p>42. Synchronizer ring (Reverse)<br/>Inspection ..... page J-32</p> <p>43. Reverse gear<br/>Inspection ..... page J-31</p> <p>44. Bearing<br/>Inspect for damage</p> <p>45. Bearing race</p> <p>46. Thrust washer</p> <p>47. Bearing cover</p> <p>48. Oil guide</p> |
|--|--|---|

37U0JX-033

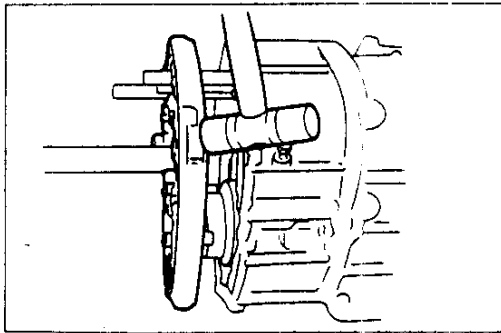

37U0.X-034

### Disassembly note Bearing housing

#### Caution

- Using metal tools to remove the bearing housing could cause severe damage to its machined surfaces.

Hit down and outward on the bearing housing with a plastic hammer to remove.

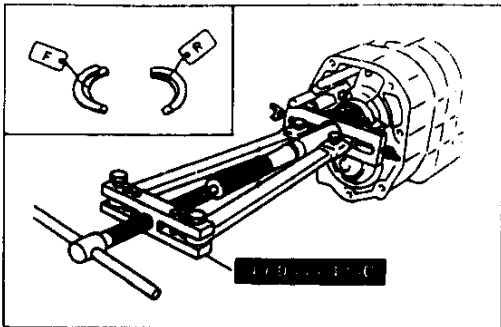

37U0JX-035

### Mainshaft rear bearing

#### Caution

- The front and rear C-washers may have different thicknesses.

1. Remove the snap ring, washer, retaining ring, and rear C-washers.
2. Remove the mainshaft rear bearing by using the **SST**.
3. Remove the retaining ring and the front C-washers.

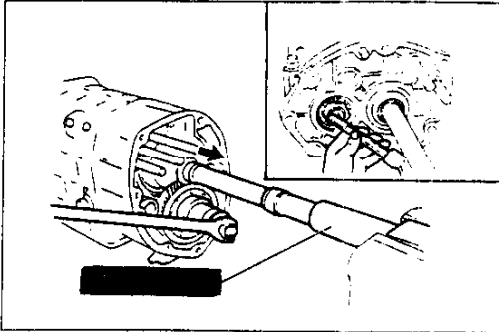

37U0JX-036

**Locknut and countershaft rear bearing**

1. Shift the 1st/2nd shift rod to 1st gear.

**Caution**

- Do not reuse the locknut.
- Do not scratch or damage the countershaft.

2. Uncrimp the tab of the locknut.
3. Hold the mainshaft by using the **SST** and a vise.
4. Remove the locknut.

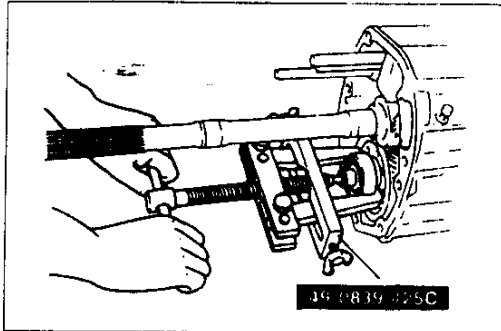

37U0JX-037

5. Remove the countershaft rear bearing by using the **SST**.

**Center housing**

1. Remove the set bolt and washer from the center housing.

**Note**

- If the center housing is difficult to remove, tap around the edge of the center housing with a plastic hammer.

2. Remove the center housing.

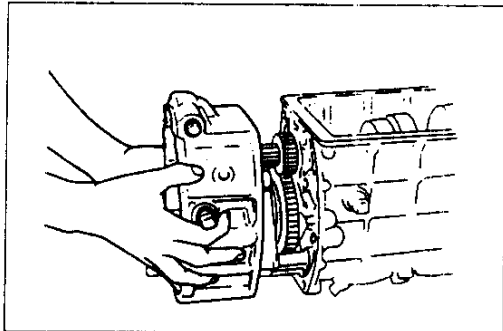

37U0JX-038

**5th/Reverse shift rod**

1. Remove the three cap plugs, packings, detent balls, and springs.

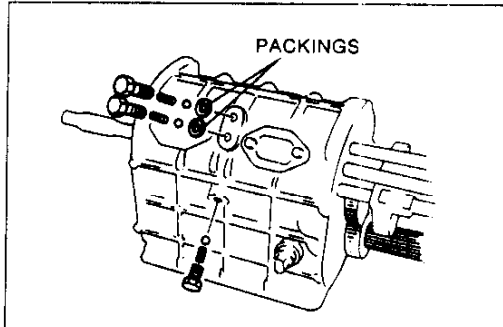

37U0JX-039

2. Drive the roll pin from the 5th/Reverse shift fork.

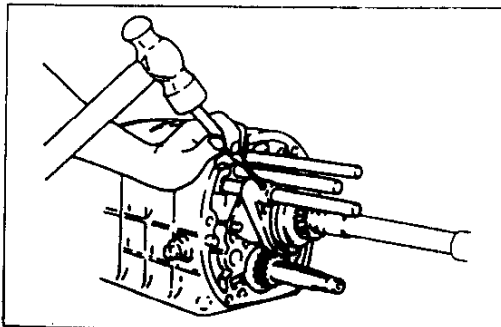

37U0JX-040

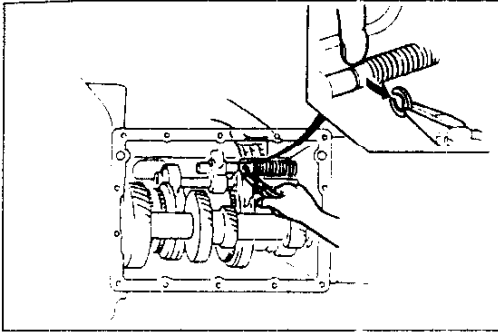

37U0JX-041

3. Pull the retaining ring from the 5th/Reverse shift rod.
4. Slide the 5th/Reverse shift rod out of the transmission case, and remove the spring.

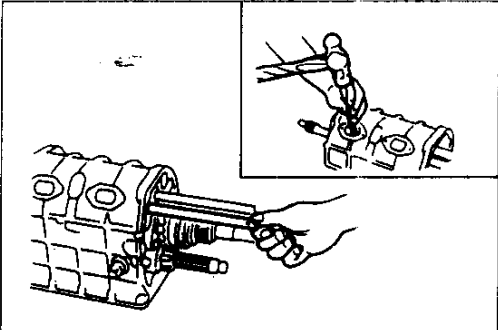

37U0JX-042

### 1st/2nd and 3rd/4th shift rods

1. Shift the transmission into 4th gear to gain access to the roll pin. Drive the roll pin from the 3rd/4th shift fork.
2. Slide the 3rd/4th shift rod and interlock pin (small) out from the rear of the transmission case.
3. Drive the roll pin from the 1st/2nd shift fork. Slide the 1st/2nd shift rod out from the rear of the transmission case, and remove the interlock pin (large).

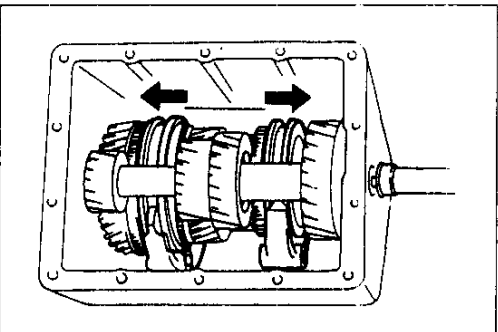

37U0JX-043

### Locknut

1. Uncrimp the tab of the locknut.
2. Shift into 1st and 4th gears to lock the rotation of the mainshaft.

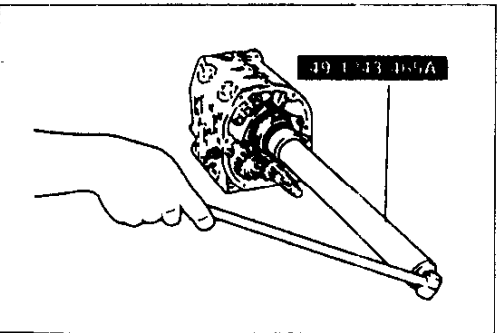

37U0JX-044

### Caution

- Do not reuse the locknut.

3. Remove the locknut by using the **SST**.

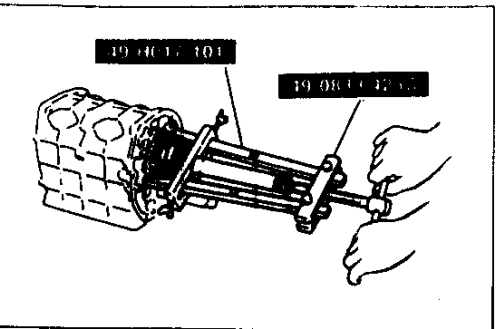

37U0JX-045

### 5th/Reverse clutch hub assembly

1. Remove the bearing cover installation bolts.
2. Attach the **SST** to the bearing cover and remove the assembly, which consists of the following parts:
  - 5th/Reverse clutch hub assembly
  - Synchronizer ring
  - Needle bearing
  - Bearing race
  - Reverse gear
  - Thrust washer

Transmission Case Components

Disassemble in the order shown in the figure, referring to **Disassembly Note**.

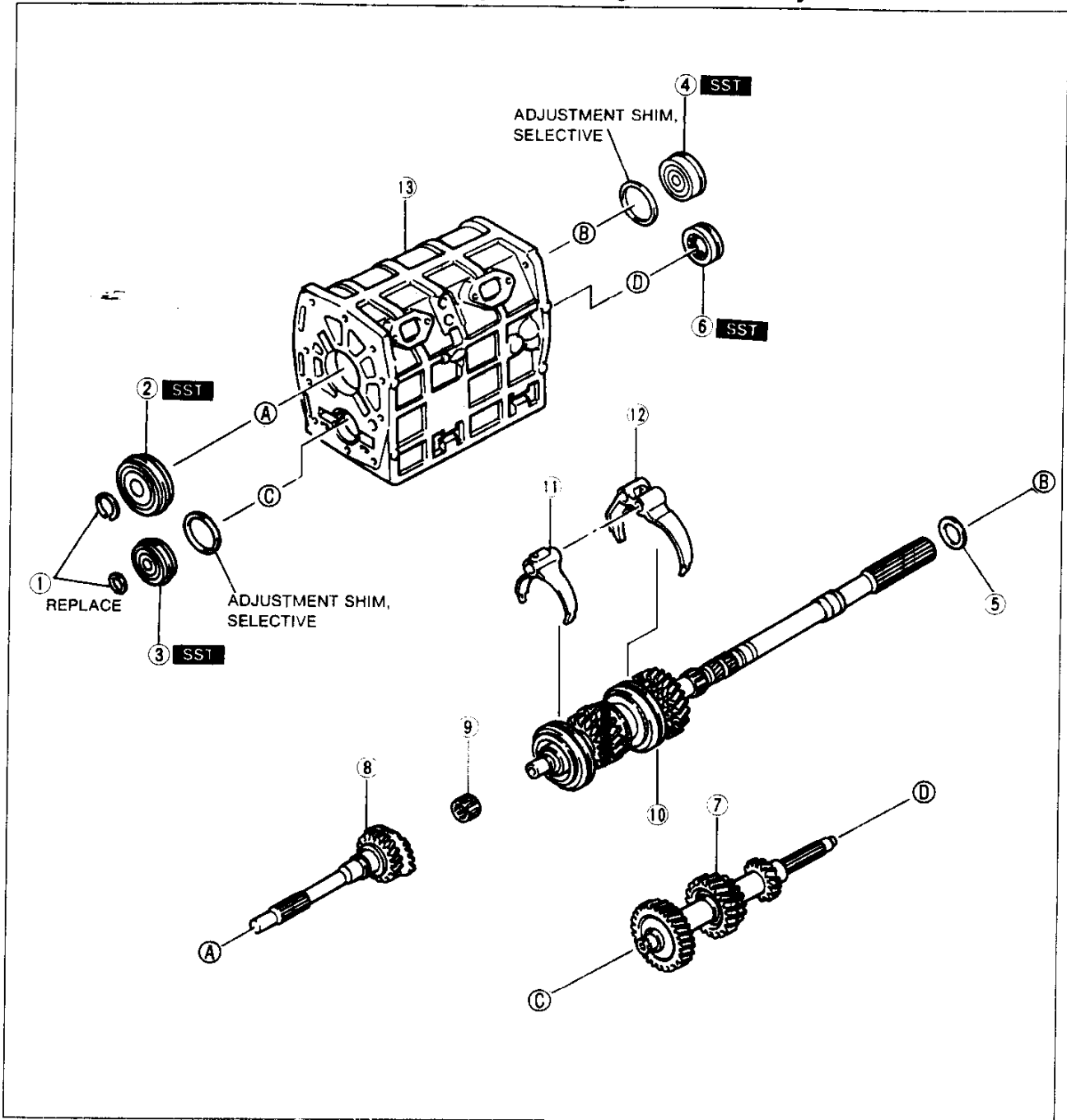

37U0JX-046

- 1. Snap rings  
Disassembly Note  
..... page J-23
- 2. Main drive gear bearing  
Disassembly Note  
..... page J-23  
Inspect for damage
- 3. Countershaft front bearing  
Disassembly Note  
..... page J-23  
Inspect for damage

- 4. Mainshaft front bearing  
Disassembly Note  
..... page J-24  
Inspect for damage
- 5. Thrust washer
- 6. Countershaft center bearing  
Disassembly Note  
..... page J-24  
Inspect for damage
- 7. Countershaft assembly

- 8. Main drive gear  
Inspection ..... page J-31
- 9. Bearing
- 10. Mainshaft gear assembly  
Disassembly Note  
..... page J-24
- 11. 3rd/4th shift fork
- 12. 1st/2nd shift fork
- 13. Transmission case

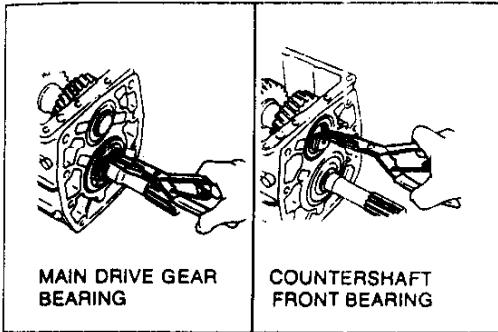

37U0JX-047

## Disassembly note Snap rings

### Caution

- Do not reuse the snap rings.

Remove the snap rings from the mainshaft and the countershaft by using snap ring pliers.

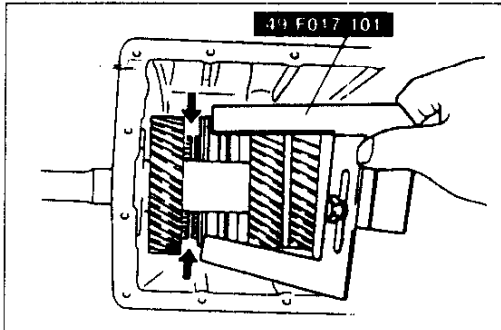

37U0JX-048

## Main drive gear bearing

1. Install the **SST** between the 4th gear synchronizer ring and main drive synchromesh gear.

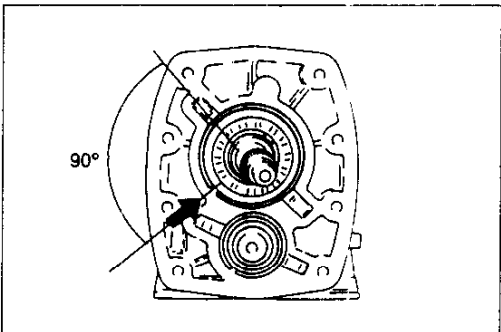

37U0JX-049

2. Turn the bearing snap rings so that the ends are 90° to the transmission case grooves.

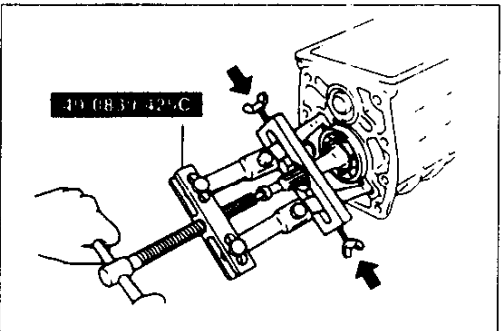

37U0JX-050

### Caution

- Be extremely careful not to damage the bearing snap ring while using the SST (bearing puller).
- Tighten the SST side screws shown in the figure.

3. Remove the main drive gear bearing by using the **SST**.

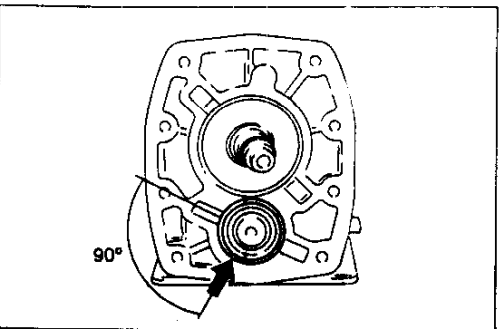

37U0JX-051

## Countershaft front bearing

1. Turn the bearing snap rings so that the ends are 90° to the transmission case grooves.



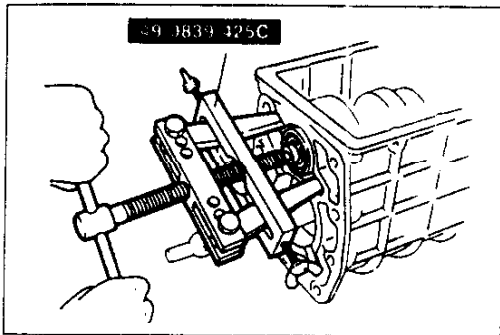

37U0JX-052

**Note**

- Replace the countershaft front bearing and countershaft front spacer as one assembly.

2. Remove the countershaft front bearing by using the **SST**.

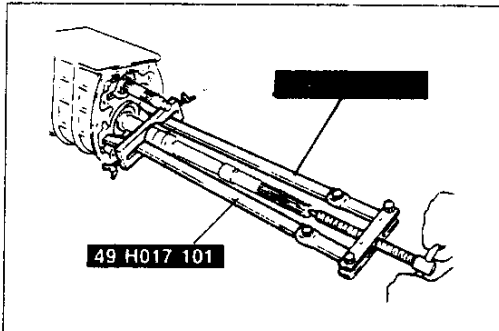

37U0JX-053

**Mainshaft front bearing**

Remove the mainshaft front bearing by using the **SST**.

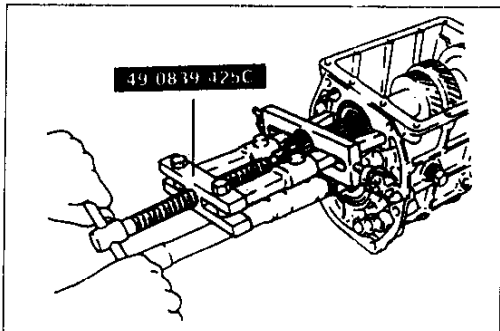

37U0JX-054

**Countershaft center bearing**

1. Remove the countershaft center bearing by using the **SST**.

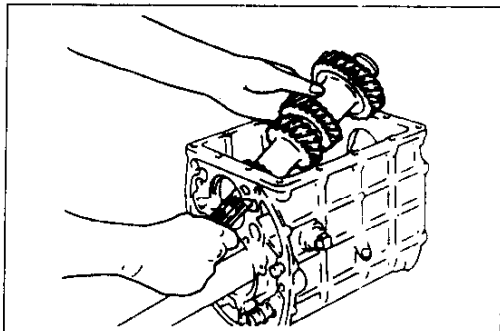

37U0JX-055

**Caution**

- Do not damage the transmission case or countershaft.

2. Remove the countershaft.

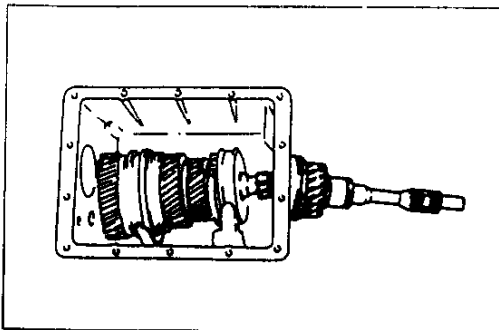

37U0JX-056

**Mainshaft gear assembly**

**Caution**

- Do not damage the main drive gear bearing bore.

1. Remove the main drive gear from the transmission case.
2. Remove the needle bearing from the mainshaft joint of the main drive gear.

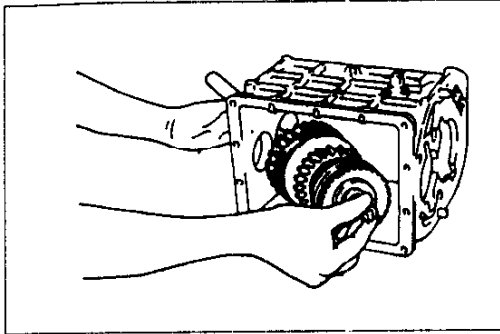

37U0JX-057

3. Remove the mainshaft gear assembly from the transmission case.

# J

## TRANSMISSION

### Mainshaft and Countershaft Components

#### Caution

- Do not remove the countershaft center bearing race unless necessary.

Disassemble in the order shown, referring to **Disassembly Note**.

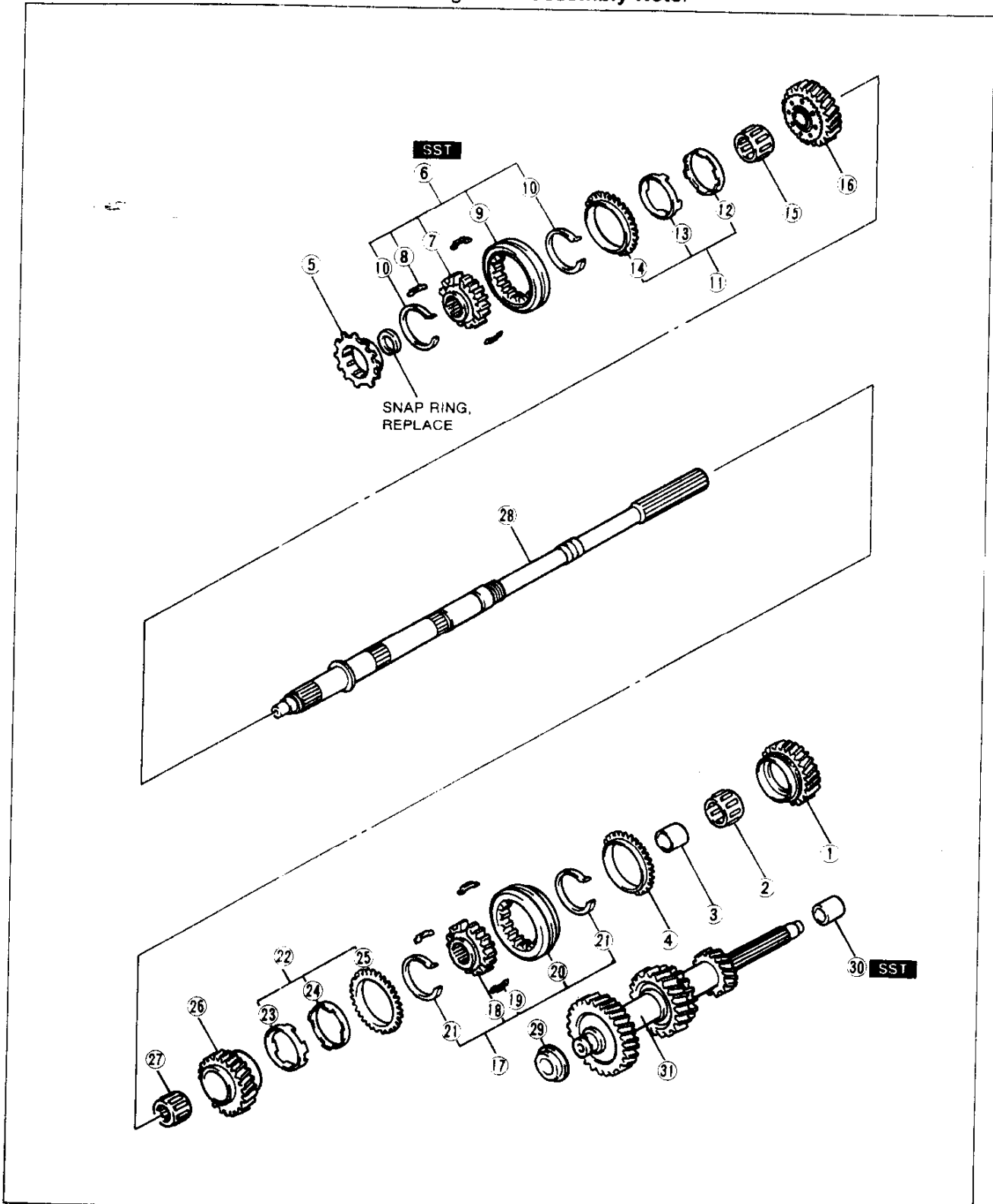

- |  |   |  |
|--|---|--|
| 1. 1st gear<br>Inspection ..... page J-31  | 12. Inner cone  | 23. Inner cone   |
| 2. Bearing<br>Inspect for damage   | 13. Double cone   | 24. Double cone  |
| 3. Bearing race  | 14. Synchronizer ring   | 25. Synchronizer ring  |
| 4. Synchronizer ring (1st)<br>Inspection ..... page J-32   | 15. Bearing<br>Inspect for damage   | 26. 2nd gear<br>Inspection ..... page J-31                                     |
| 5. Synchronizer ring (4th)<br>Inspection ..... page J-32   | 16. 3rd gear<br>Inspection ..... page J-31  | 27. Bearing<br>Inspect for damage  |
| 6. 3rd/4th clutch hub<br>assembly<br>Disassembly Note<br>..... below<br>Inspection ..... page J-32 | 17. 1st/2nd clutch hub<br>assembly<br>Disassembly Note<br>..... below<br>Inspection ..... page J-32 | 28. Mainshaft<br>Inspection ..... page J-31                                    |
| 7. 3rd/4th clutch hub  | 18. 1st/2nd clutch hub  | 29. Countershaft front<br>bearing spacer                                       |
| 8. Synchronizer key  | 19. Synchronizer key  | 30. Countershaft center<br>bearing race<br>Disassembly Note<br>..... page J-28 |
| 9. Clutch hub sleeve   | 20. Clutch hub sleeve   | 31. Countershaft<br>Inspection ..... page J-31                                 |
| 10. Synchronizer key<br>spring (3rd/4th)   | 21. Synchronizer key spring   |  |
| 11. Synchronizer assembly<br>(3rd)<br>Inspection ..... page J-33                                   | 22. Synchronizer assembly<br>(2nd)<br>Inspection ..... page J-33                                    |  |

37U0JX-059

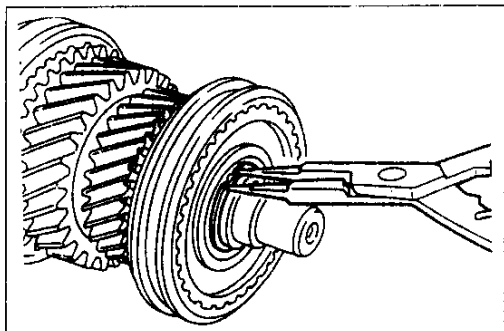

37U0JX-060

**Disassembly note  
3rd/4th clutch hub assembly**

**Caution**

- Do not reuse the snap ring.

1. Remove the snap ring from the front of the mainshaft.

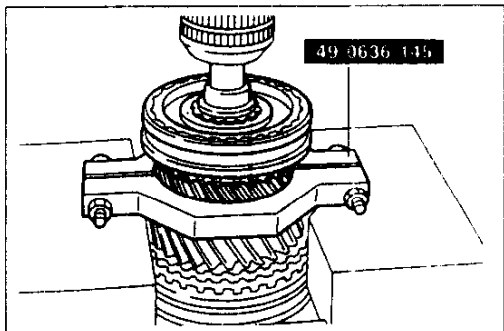

37JCJX-061

2. Position the SST between 2nd and 3rd gears.

**Caution**

- Hold the mainshaft with one hand so that it does not fall.

3. Press the mainshaft out from the 3rd gear, synchronizer ring assembly (3rd), and the 3rd/4th clutch hub assembly.

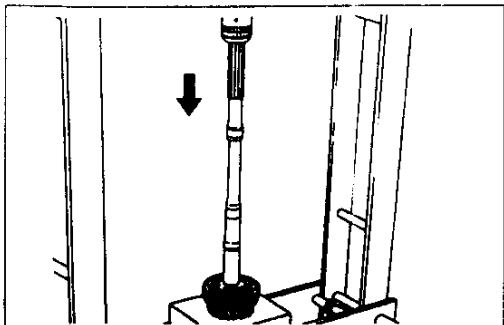

37U0JX-062

**1st/2nd clutch hub assembly**

**Caution**

- Hold the mainshaft with one hand so that it does not fall.

Press the 1st/2nd clutch hub assembly, synchronizer ring assembly (2nd), and 2nd gear from the mainshaft.

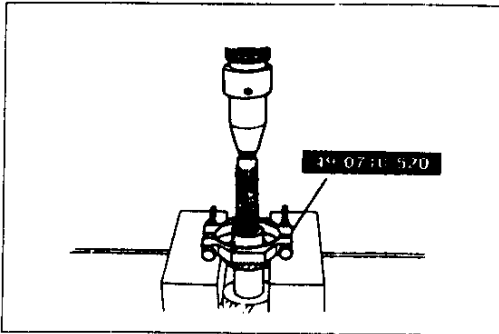

37L-0JX-063

**Countershaft center bearing race****Caution**

- Hold the countershaft with one hand so that it does not fall.

**Note**

- Replace the countershaft center bearing and bearing race as one assembly.

Remove the countershaft bearing race from the mainshaft by using the **SST**.

Extension Housing Components

Caution

● Do not remove the extension housing oil seal unless necessary.

Disassemble in the order shown, referring to **Disassembly Note**.

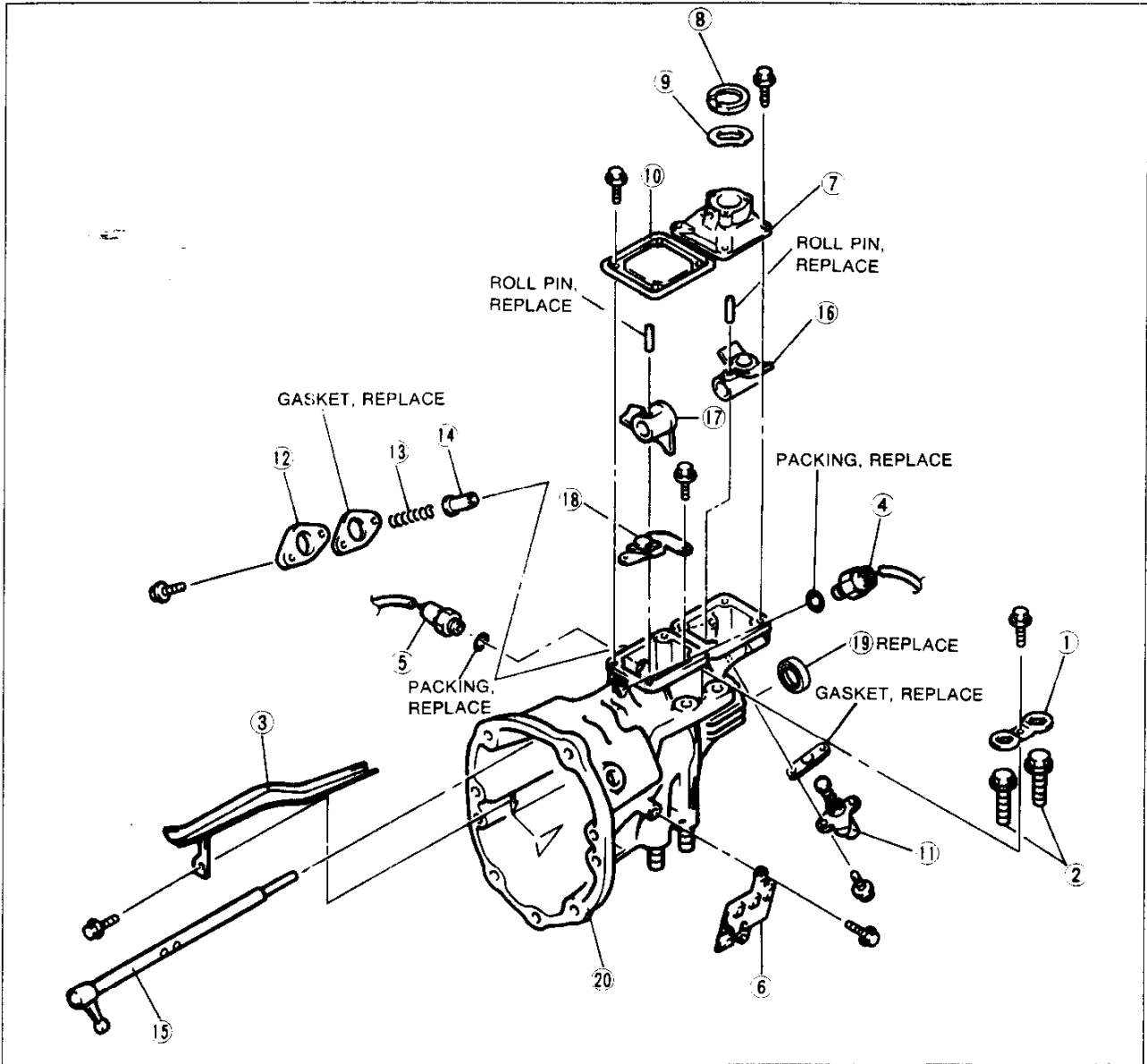

37U0JX-064

- |   |  |   |
|---|--|---|
| <p>1. Stopper</p> <p>2. Power plant frame installation bolts</p> <p>3. Oil guide</p> <p>4. Neutral switch</p> <p>5. 1-2 switch</p> <p>6. Bracket</p> <p>7. Control case</p> <p>8. Bushing<br/>Inspect for wear and damage</p> | <p>9. Wave washer<br/>Inspect for wear and damage</p> <p>10. Blind cover</p> <p>11. Select spindle assembly</p> <p>12. Spring cap</p> <p>13. Select lock spindle spring<br/>Inspection ..... page J-33</p> <p>14. Select lock spindle</p> <p>15. Control rod<br/>Disassembly Note<br/>..... page J-30<br/>Inspection ..... page J-32</p> | <p>16. Control rod end</p> <p>17. Selector</p> <p>18. Shift guide assembly</p> <p>19. Oil seal<br/>Disassembly Note<br/>..... page J-30</p> <p>20. Extension housing<br/>Inspection ..... page J-34</p> |
|---|--|---|

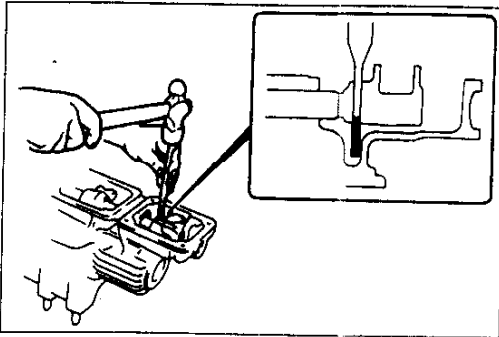

37U0JX-065

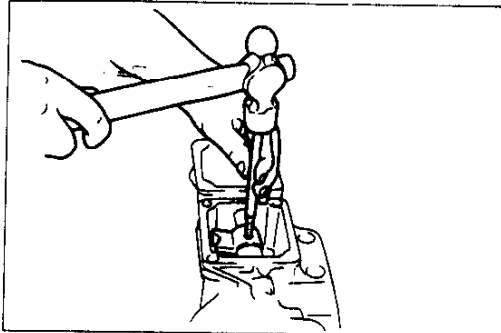

37U0JX-066

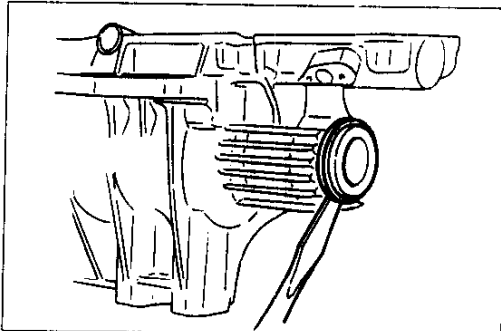

37U0IX-067

### Disassembly note Control rod

1. Slide the control rod end to the point where the roll pin is directly above the recess in the extension housing.
2. Remove the roll pin from the control rod end by using a pin punch and hammer.
3. Remove the roll pin from the selector by using a pin punch and hammer.
4. Slide the control rod from the extension housing, and remove the control rod end and selector.

### Oil seal (extension housing)

#### Caution

- **Do not scratch or damage the extension housing.**

Remove the oil seal from the extension housing by using a screwdriver.

## INSPECTION

Inspect all parts, and repair or replace as necessary.

37U0JX-068

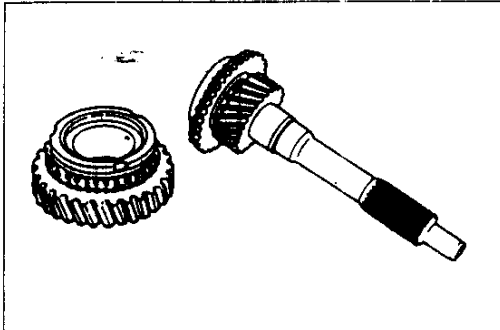

37U0JX-069

### Each Gear and Main Drive Gear

1. Inspect synchronizer cones for wear.
2. Inspect individual gear teeth for damage, wear, and cracks.
3. Inspect synchronizer ring matching teeth for damage and wear.
4. Inspect main drive gear splines for damage and wear.

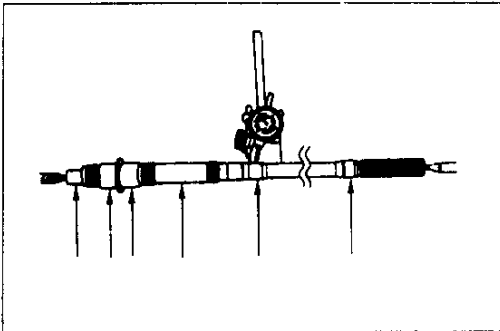

37U0JX-070

### Mainshaft

1. Measure the mainshaft runout.
  - Runout: 0.03 mm {0.0012 in} max.**
2. Inspect splines for damage and wear.

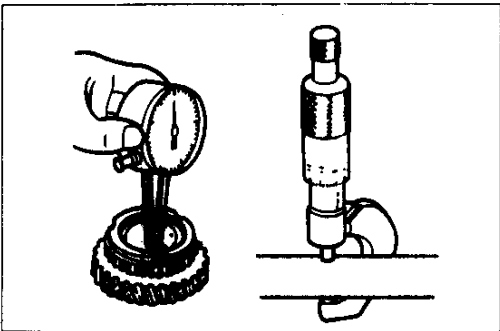

37U0JX-071

3. Measure the clearance between mainshaft and gear (or bushing).
  - Clearance: 0.15 mm {0.006 in} max.**

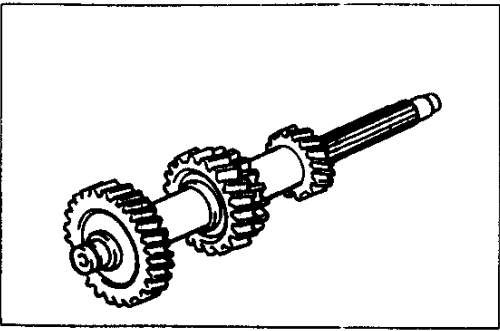

37U0JX-072

### Countershaft

1. Inspect gear teeth for damage, wear, and cracks.
2. Inspect splines for damage and wear.



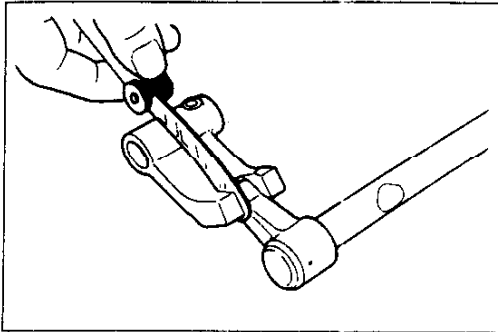

37U0JX-073

**Control Rod Lever and Shift Rod**

Measure the clearance between the control rod lever and the shift rod gate.

**Clearance: 0.8 mm {0.031 in} max.**

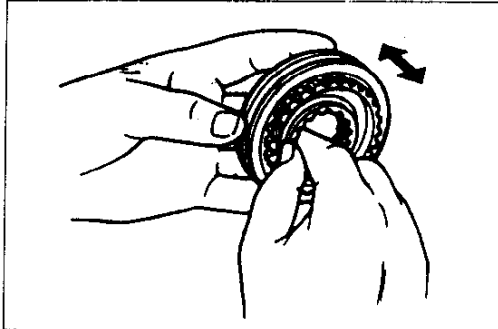

37U0JX-074

**Each Clutch Hub Assembly**

1. Inspect clutch hub sleeve and hub operation.
2. Inspect individual gear teeth for damage, wear, and cracks.
3. Inspect synchronizer keys for damage, wear, and cracks.

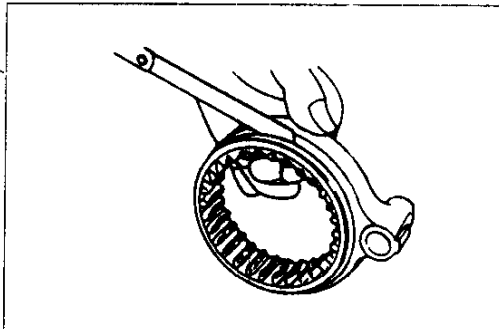

37U0JX-075

4. Measure the clearance between the hub sleeve groove and shift fork.

**Clearance:**

**0.2–0.3 mm {0.008–0.012 in}**

**Maximum: 0.5 mm {0.020 in}**

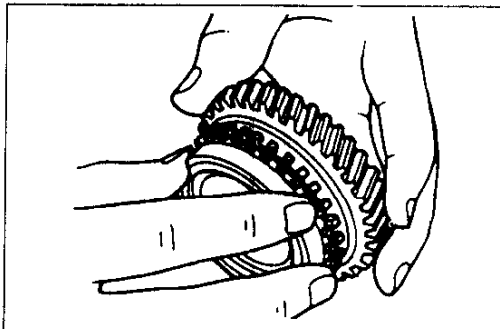

37U0JX-076

**Synchronizer Ring (1st, 4th, 5th, Reverse)**

1. Inspect individual synchronizer ring teeth for damage, wear, and cracks.
2. Inspect taper surface for wear and cracks.

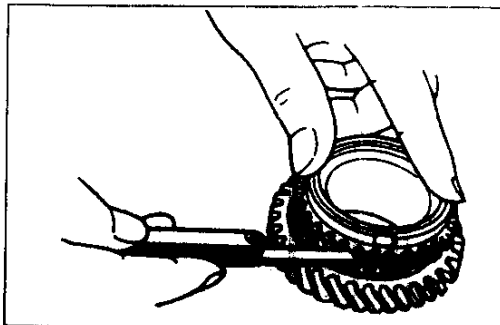

37U0JX-077

**Note**

- **Set the synchronizer ring squarely in the gear.**

3. Measure the clearance between the synchronizer ring and flank surface of gear.

**Clearance: 1.5 mm {0.059 in}**

**Minimum: 0.8 mm {0.031 in}**

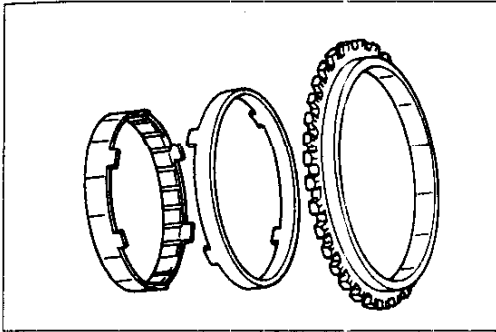

37U0JX-078

**Synchronizer Assembly (2nd/3rd)**

**Caution**

- If any part of the synchronizer assembly is damaged, replace the assembly as a whole.

1. Inspect individual synchronizer ring gear teeth for damage, wear, and cracks.
2. Inspect for wear and damage to the tapered surfaces of the inner cone, double cone, and synchronizer ring.

**Note**

- Set the synchronizer assembly squarely in the gear.

3. Measure the clearance between the synchronizer ring and flank surface of gear.

**Clearance: 1.5 mm {0.059 in}**  
**Minimum: 0.8 mm {0.031 in}**

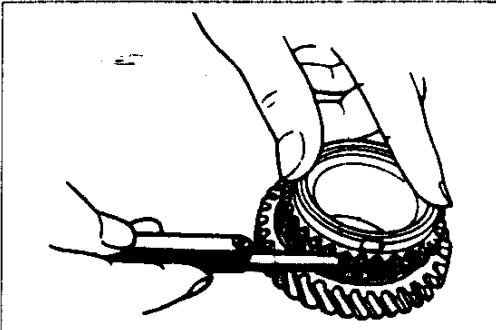

37U0JX-079

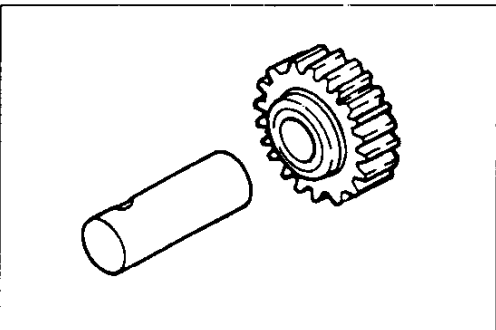

37J6JX-080

**Reverse Idler Gear and Shaft**

1. Inspect gear teeth for damage, wear, and cracks.

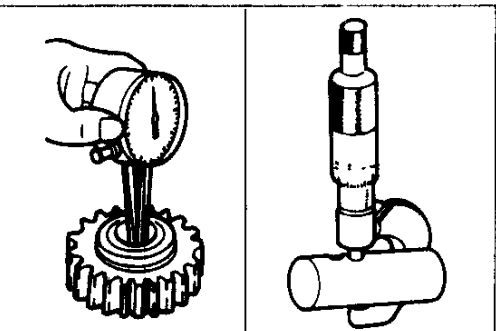

37U0JX-081

2. Measure the clearance between the reverse idler gear bushing and shaft.

**Clearance:**  
**0.02–0.05 mm {0.0008–0.0020 in}**  
**Maximum: 0.15 mm {0.006 in}**

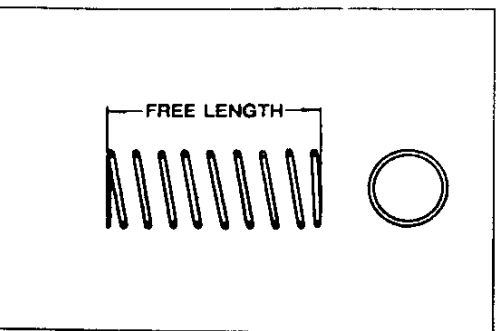

37U0JX-082

**Spring**

Measure the free length of the spring.

**Standard free length: mm {in}**  
**Detent ball spring: 22.5 {0.886}**  
**5th/Reverse retaining spring: 73.00 {2.874}**  
**Select lock spindle spring: 43.25 {1.703}**

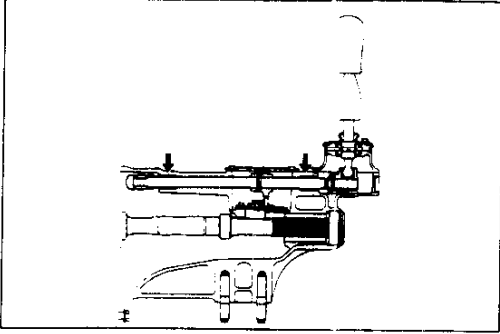

37U0JX-083

**Extension Housing**

1. Inspect the indicated bearings for damage.
2. Replace the extension housing if necessary.

## ASSEMBLY

### Precaution

1. Make sure each part is cleaned before assembling.
2. Coat all movable parts with the specified oil.
3. Replace parts wherever required.
4. Remove old sealant from contact surfaces before applying new sealant.
5. Assemble the parts within 10 minutes after applying sealant. Allow all sealant to cure at least 30 minutes after assembly before filling the transmission with transmission oil.
6. When using a vise, insert protective plates to prevent damage to the part.

37U0JX-084

### Extension Housing Components

Assemble in the order shown, referring to **Assembly Note**.

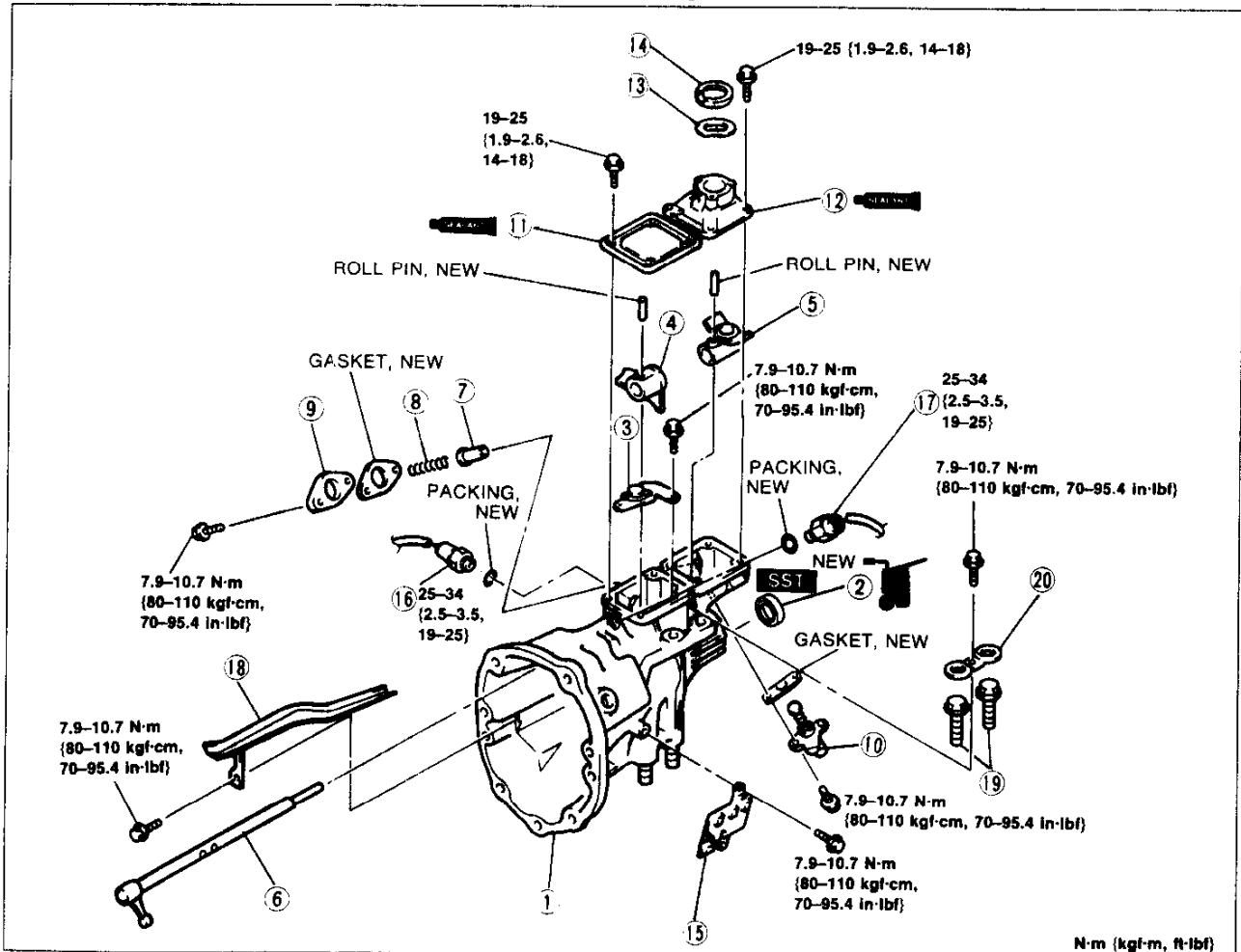

N-m (kgf-m, ft-lbf)

37U0JX-085

- |  |   |  |
|--|---|--|
| <p>1. Extension housing</p> <p>2. Oil seal (extension housing)<br/>Assembly Note<br/>..... page J-36</p> <p>3. Shift guide assembly</p> <p>4. Selector</p> <p>5. Control rod end</p> <p>6. Control rod<br/>Assembly Note<br/>..... page J-36</p> | <p>7. Select lock spindle</p> <p>8. Select lock spindle spring</p> <p>9. Spring cap</p> <p>10. Select spindle assembly</p> <p>11. Blind cover<br/>Assembly Note<br/>..... page J-36</p> <p>12. Control case<br/>Assembly Note<br/>..... page J-36</p> | <p>13. Wave washer</p> <p>14. Bushing</p> <p>15. Bracket</p> <p>16. 1-2 switch</p> <p>17. Neutral switch</p> <p>18. Oil guide</p> <p>19. Power plant frame<br/>installation bolts</p> <p>20. Stopper</p> |
|--|---|--|

# J

## TRANSMISSION

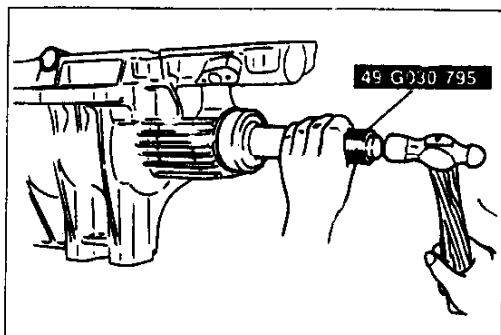

37U0JX-086

### Assembly note

#### Oil seal (extension housing)

1. Apply clean oil to the lip and outer edge of a new oil seal.
2. Install the oil seal evenly and gradually by using the SST.

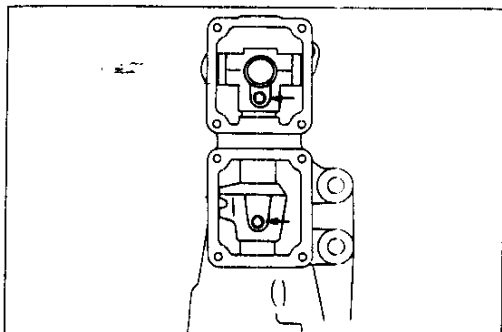

37U0JX-087

### Control rod

1. Install the control rod through the selector and control rod end, into the extension housing.
2. Install new roll pins into the selector and control rod ends as shown in the figure.

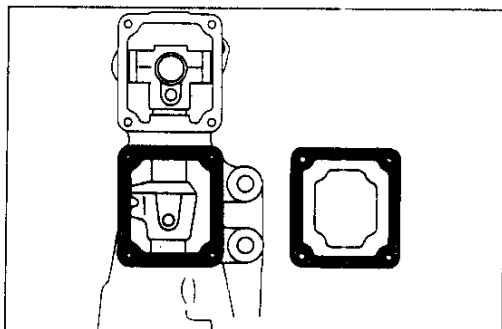

37U0JX-088

### Blind cover

1. Apply sealant to the contact surfaces of the blind cover and extension housing.
2. Install the blind cover.

### Tightening torque:

**19–25 N·m {1.9–2.6 kgf·m, 14–18 ft·lbf}**

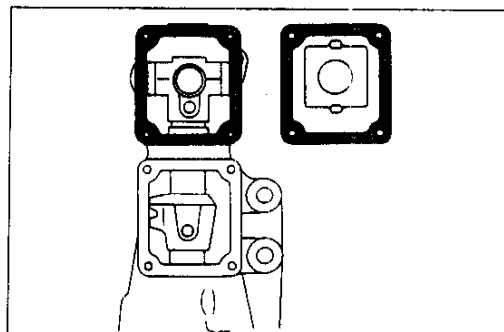

37U0JX-089

### Control case

1. Apply sealant to the contact surfaces of the extension housing and control case.
2. Install the control case to the extension housing.

### Tightening torque:

**19–25 N·m {1.9–2.6 kgf·m, 14–18 ft·lbf}**

---

MEMO

# J

## TRANSMISSION

### Mainshaft and Countershaft Components

Assemble in the order shown, referring to **Assembly Note**.

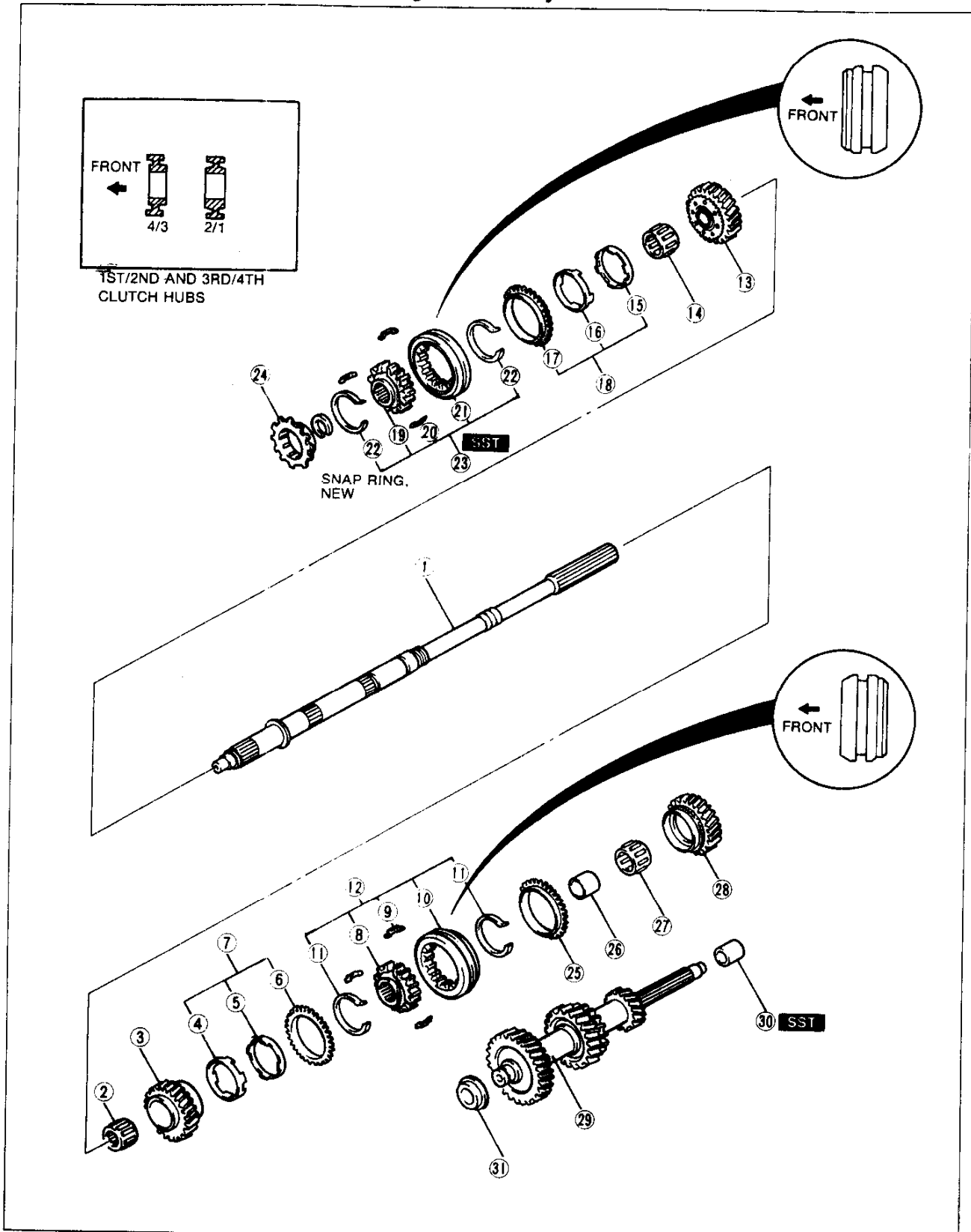

37U0JX-090

- |                                 |                                 |                                       |
|---------------------------------|---------------------------------|---------------------------------------|
| 1. Mainshaft                    | 13. 3rd gear                    | 25. Synchronizer ring (1st)           |
| 2. Bearing                      | 14. Bearing                     | 26. Bearing race                      |
| 3. 2nd gear                     | 15. Inner cone                  | 27. Bearing                           |
| 4. Inner cone                   | 16. Double cone                 | 28. 1st gear                          |
| 5. Double cone                  | 17. Synchronizer ring           | 29. Countershaft                      |
| 6. Synchronizer ring            | 18. Synchronizer assembly (3rd) | 30. Countershaft center bearing race  |
| 7. Synchronizer assembly (2nd)  | Assembly Note ..... below       | Assembly Note                         |
| Assembly Note ..... below       | 19. 3rd/4th clutch hub          | ..... page J-41                       |
| 8. 1st/2nd clutch hub           | 20. Synchronizer key            | 31. Countershaft front bearing spacer |
| 9. Synchronizer key             | 21. Clutch hub sleeve           | Assembly Note                         |
| 10. Clutch hub sleeve           | 22. Synchronizer key spring     | ..... page J-41                       |
| 11. Synchronizer key spring     | 23. 3rd/4th clutch hub assembly |                                       |
| 12. 1st/2nd clutch hub assembly | Assembly Note ..... below       |                                       |
| Assembly Note ..... below       | 24. Synchronizer ring (4th)     |                                       |

37U0JX-091

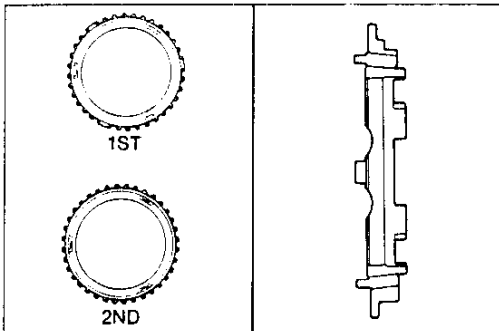

37J0JX-092

**Assembly note**

**Synchronizer assembly (2nd, 3rd)**

**Note**

- The 1st and 2nd synchronizer rings can be easily distinguished by noting that the 1st synchronizer ring has two teeth fused together at three equally spaced places around its outer edge. The 2nd synchronizer ring has no distinguishing marks.

Install the inner cone, double cone, and synchronizer ring as shown in the figure.

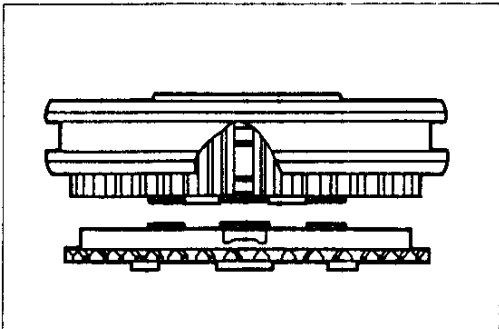

37J0JX-093

**Clutch hub assembly (1st/2nd, 3rd/4th)**

**Caution**

- Align the synchronizer ring grooves (2nd, 3rd) with the synchronizer keys during installation.
- Align the slots in the clutch hub with the tabs on the inner cone.

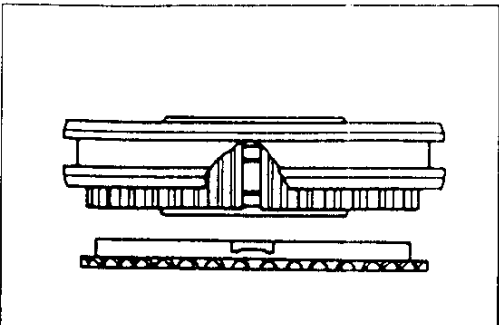

37U0JX-094

- Align the synchronizer ring grooves (1st, 4th) with the synchronizer keys.



# J

## TRANSMISSION

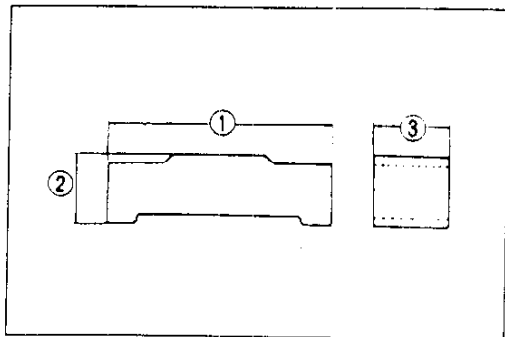

37U0JX-095

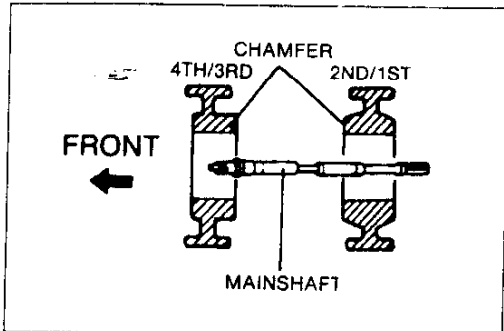

37U0JX-096

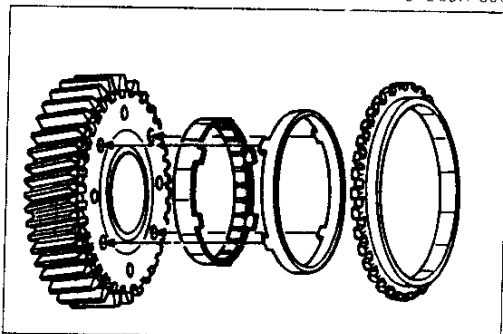

37J0JX-097

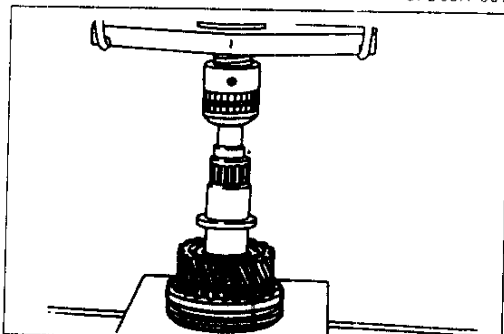

37U0JX-098

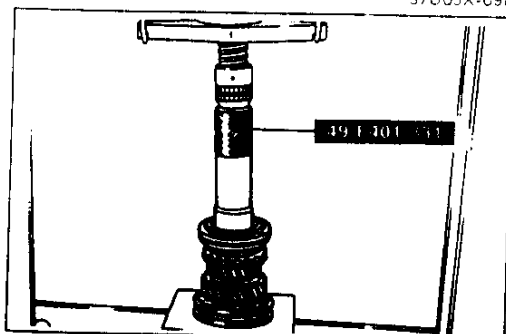

37U0JX-099

### Note

- Standard key dimensions are as follows:

	mm {in}		
	1	2	3
1st and 2nd	18.00 {0.709}	5.45 {0.215}	6.00 {0.236}
3rd and 4th	17.00 {0.669}	4.25 {0.167}	5.00 {0.197}

### Caution

- Press each clutch hub assembly onto the mainshaft in the proper direction as shown.

### Caution

- Do not damage parts while using the press.
- Install the double cone pegs into the holes in the flank side of the gear as shown in the figure.

- 1 Set the needle bearing, 2nd gear, synchronizer assembly (2nd), and the 1st/2nd clutch hub assembly on the mainshaft, then press in the mainshaft.

- 2 Set the needle bearing, 3rd gear, synchronizer assembly (3rd), and 3rd/4th clutch hub assembly on the mainshaft, then press them onto the mainshaft by using the SST.

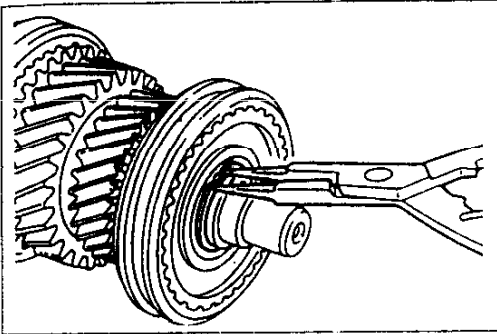

37U0JX-100

3. Install a new snap ring on the front of the mainshaft.

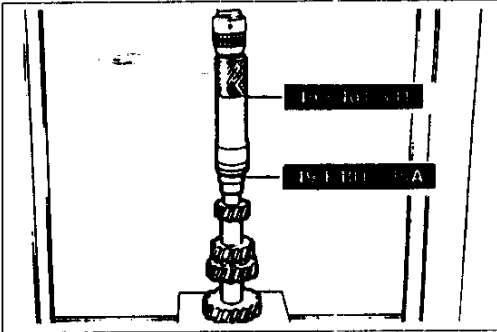

37U0JX-101

**Countershaft center bearing race**

Press the countershaft center bearing race onto the countershaft by using the **SST**.

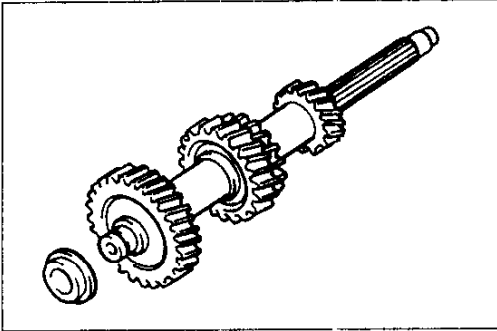

37U0JX-102

**Countershaft front bearing spacer**

**Note**

- **Replace the countershaft front bearing and countershaft front bearing spacer as one assembly.**

Install the countershaft front bearing spacer.

# J

## TRANSMISSION

### Transmission Case Components

Assemble in the order shown, referring to **Assembly Note**.

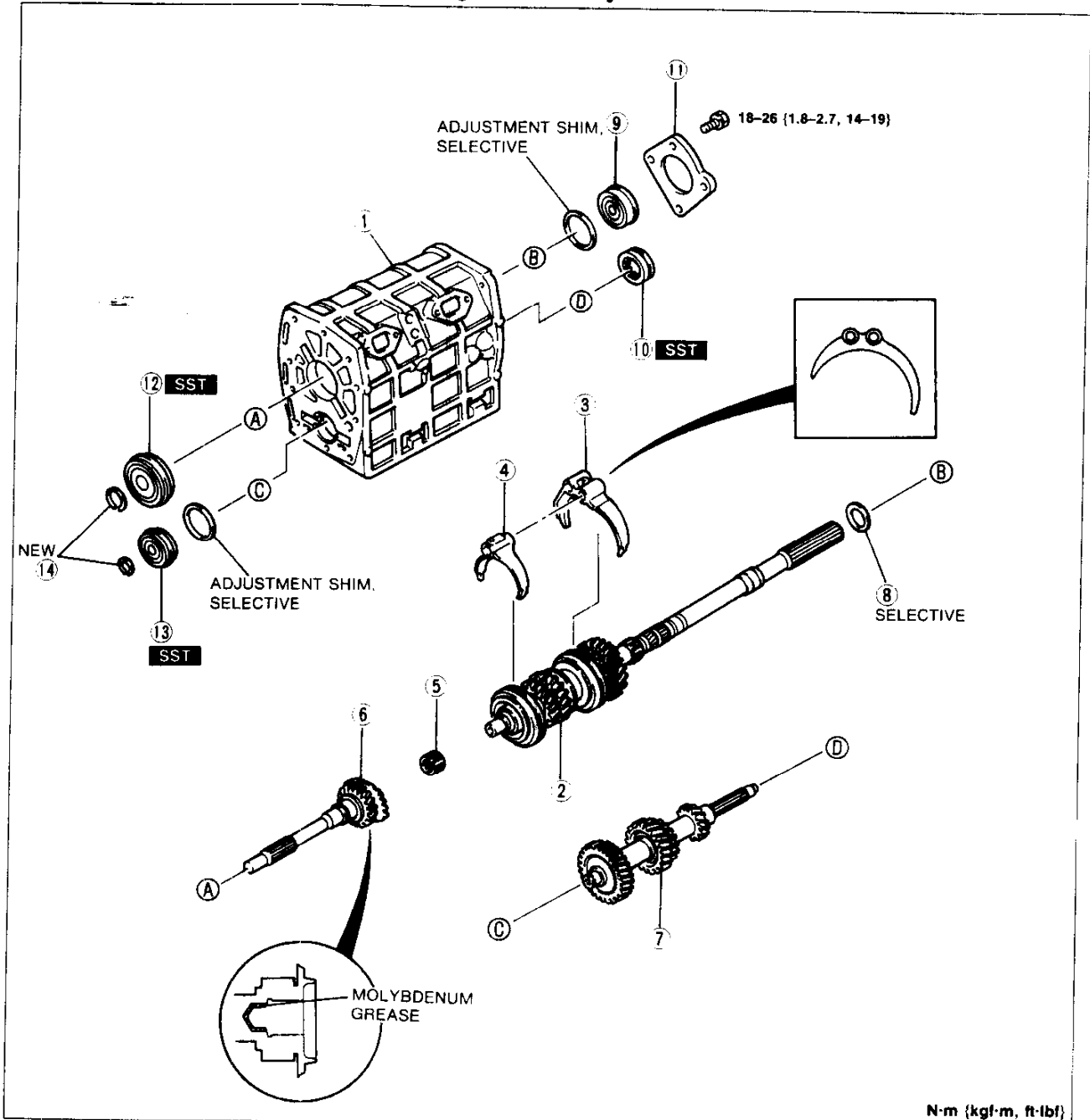

N·m (kgf·m, ft·lbf)

37U0JX-103

- |  |  |  |
|--|--|--|
| 1. Transmission case<br>Assembly Note<br>..... page J-43 | 7. Countershaft assembly<br>8. Thrust washer<br>9. Mainshaft front bearing<br>Assembly Note<br>..... page J-44 | 12. Main drive gear bearing<br>Assembly Note<br>..... page J-44    |
| 2. Mainshaft gear assembly                               | 10. Countershaft center<br>bearing<br>Assembly Note<br>..... page J-44   | 13. Countershaft front bearing<br>Assembly Note<br>..... page J-45 |
| 3. 1st/2nd shift fork                                    | 11. Bearing cover  | 14. Snap rings   |
| 4. 3rd/4th shift fork                                    |  |  |
| 5. Bearing   |  |  |
| 6. Main drive gear                                       |  |  |

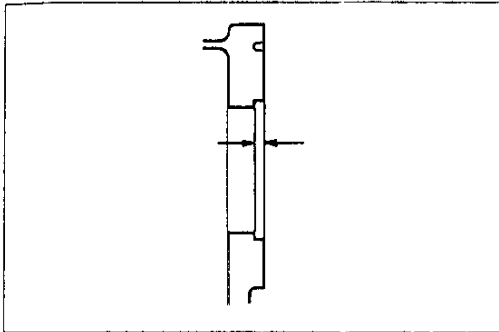

37U0JX-104

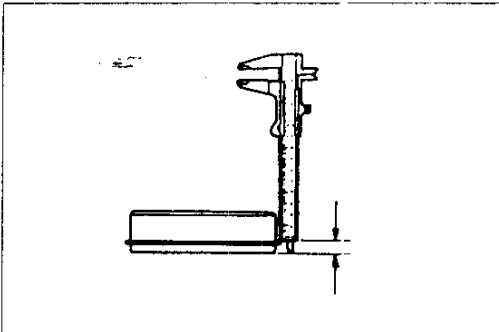

37U0JX-105

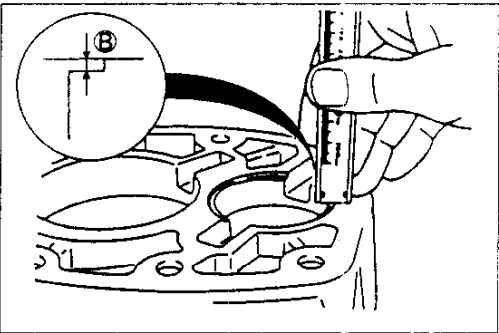

37U0JX-106

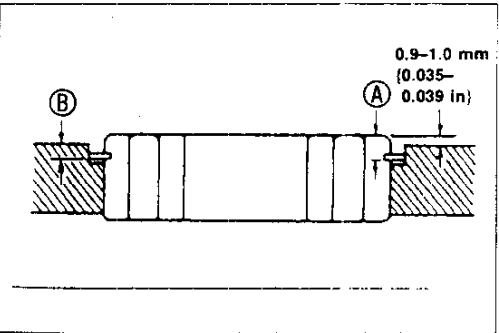

37J0JX-107

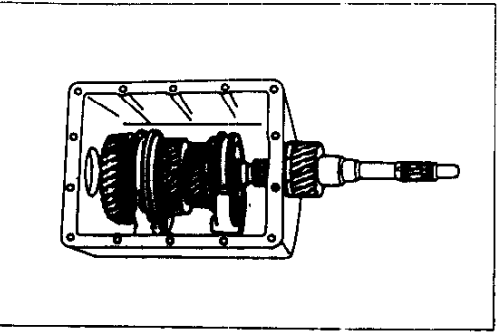

37U0JX-108

**Assembly note**  
**Transmission case**

1. Measure the mainshaft front bearing thrust play as follows.

(1) Measure the depth of the mainshaft front bearing bore in the rear of the transmission case.

(2) Measure the mainshaft front bearing height. The difference between the two measurements indicates the required thickness of the adjustment shim.

**Standard thrust play:**

**0-0.05 mm {0-0.002 in}**

**Adjustment shim thicknesses:**

**0.1 mm {0.004 in}, 0.3 mm {0.012 in}**

2. Measure the countershaft front bearing thrust play as follows.

(1) Measure depth B of the countershaft front bearing bore in the transmission case.

(2) Measure the countershaft front bearing snap ring height A.

(3) Choose an adjustment shim that will allow the difference between the two measurements to be equal to the standard bearing height.

**A-B + Adjustment shim(s) = 0.9-1.0 mm {0.035-0.039 in}**

**Standard bearing height on installing:**

**0.9-1.0 mm {0.035-0.039 in}**

**Adjustment shim thicknesses:**

**0.1 mm {0.004 in}, 0.3 mm {0.012 in}**

3. Position the 1st/2nd and 3rd/4th shift forks into the grooves of the clutch hub and sleeve assemblies.

4. Apply molybdenum grease to the needle bearing and install it in the main drive gear.

5. Install the main drive gear onto the front of the mainshaft.

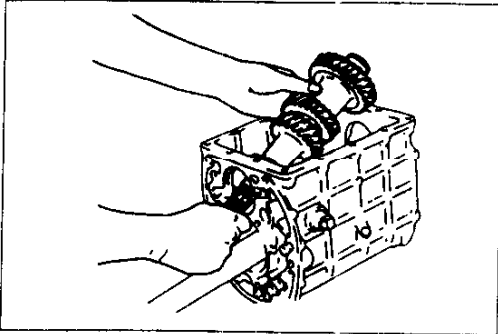

37U0JX-109

- Set the countershaft assembly into the case, making sure the countershaft gears engage each gear of the mainshaft assembly.

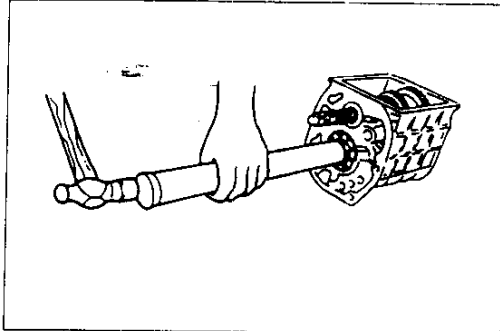

37U0JX-110

**Mainshaft front bearing**

- Install the correct shim onto the rear of the mainshaft as determined in the transmission case assembly note (page J-43.)
- Install the mainshaft front bearing with a suitable pipe.

**Bearing inner diameter: 32 mm {1.3 in}**  
**Bearing outer diameter: 75 mm {3.0 in}**

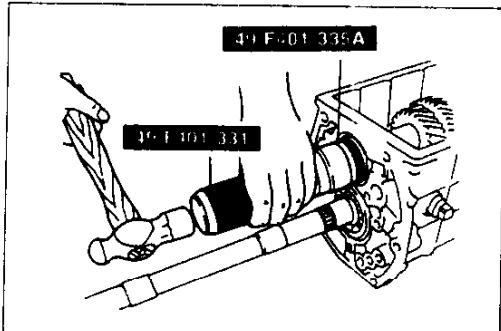

37U0JX-111

**Countershaft center bearing**

- Install the countershaft center bearing onto the rear of the countershaft by using the **SST**.

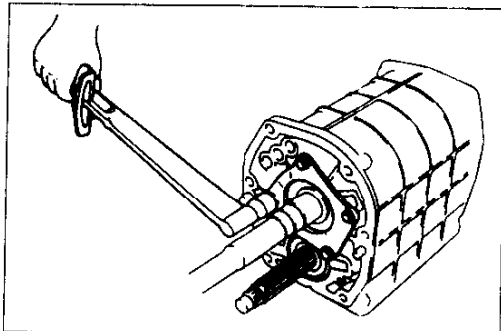

37U0JX-112

- Install the bearing cover.

**Tightening torque:**  
**18-26 N·m {1.8-2.7 kgf·m, 14-19 ft·lbf}**

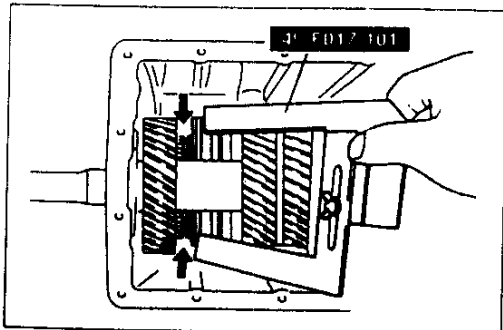

37U0JX-113

**Main drive gear bearing**

- Install the **SST** between the 4th synchronizer ring and the main drive synchromesh gear.

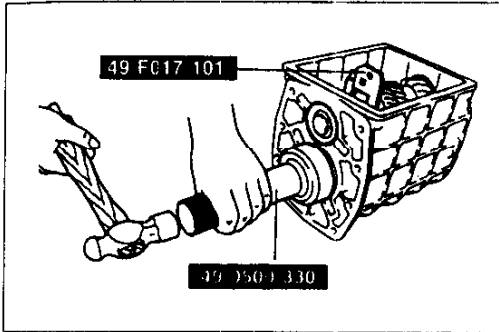

37U0JX-114

2. Install the main drive gear bearing by using the **SST**.

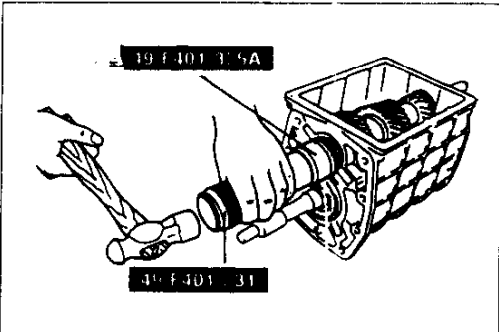

37U0JX-115

**Countershaft front bearing**

**Note**

- Replace the countershaft front bearing and countershaft front bearing spacer as an assembly.

1. Install the correct shim onto the countershaft front bearing as determined in the transmission case assembly note (page J-43.)
2. Install the countershaft front bearing by using the **SST**.

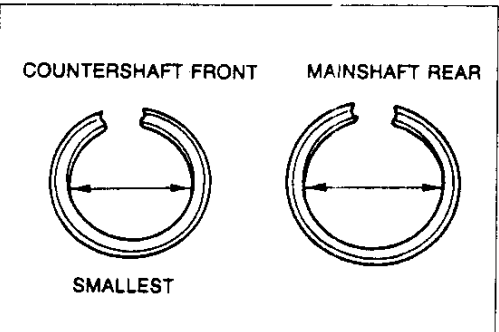

37U0JX-116

**Note**

- Do not confuse the front and rear bearing snap rings. The countershaft front snap ring is the smallest.

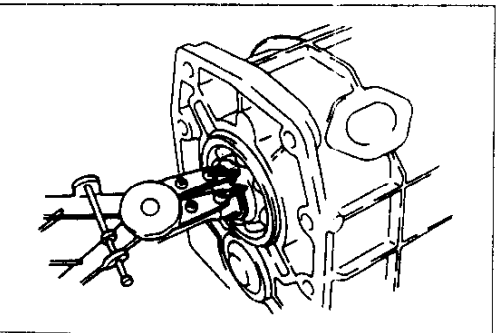

37U0JX-117

3. Install new snap rings to the main drive gear and countershaft gear.

5th/Reverse Gear and Housing Components

Assemble in the order shown, referring to **Assembly Note**.

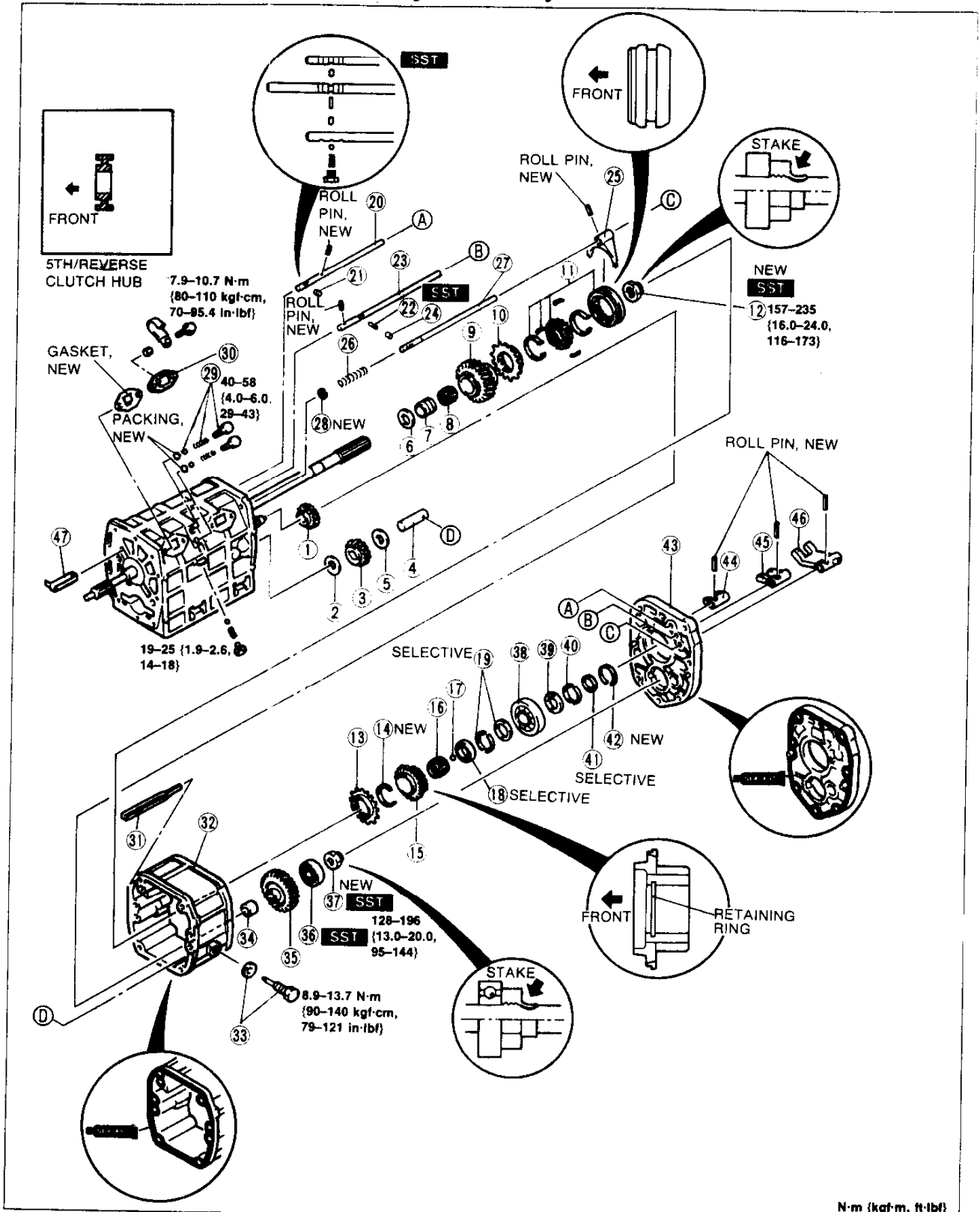

N·m (kgf·m, ft·lbf)

37U0JX-118

- |  |   |   |
|--|---|---|
| <ol style="list-style-type: none"> <li>1. Counter reverse gear</li> <li>2. Thrust washer</li> <li>3. Reverse idler gear</li> <li>4. Reverse idler gear shaft</li> <li>5. Thrust washer</li> <li>6. Thrust washer</li> <li>7. Bearing race</li> <li>8. Bearing</li> <li>9. Reverse gear</li> <li>10. Synchronizer ring (Reverse)<br/>Assembly Note ..... below</li> <li>11. 5th/Reverse clutch hub assembly<br/>Assembly Note ..... below</li> <li>12. Locknut<br/>Assembly Note ..... below</li> <li>13. Synchronizer ring (5th)<br/>Assembly Note ..... below</li> <li>14. Retaining ring</li> <li>15. 5th gear<br/>Assembly Note ..... page J-48</li> <li>16. Bearing</li> <li>17. Steel ball</li> </ol> | <ol style="list-style-type: none"> <li>18. Thrust lock washer</li> <li>19. C-washers and retaining ring</li> <li>20. 1st/2nd shift rod<br/>Assembly Note ..... page J-49</li> <li>21. Interlock pin (large)</li> <li>22. Interlock pin (small)</li> <li>23. 3rd/4th shift rod<br/>Assembly Note ..... page J-49</li> <li>24. Interlock pin (large)</li> <li>25. 5th/Reverse shift fork<br/>Assembly Note ..... page J-49</li> <li>26. Spring</li> <li>27. 5th/Reverse shift rod<br/>Assembly Note ..... page J-49</li> <li>28. Retaining ring</li> <li>29. Cap plug, spring, and detent ball</li> <li>30. Blind cover</li> <li>31. Oil guide</li> <li>32. Center housing<br/>Assembly Note ..... page J-50</li> </ol> | <ol style="list-style-type: none"> <li>33. Set bolt and washer</li> <li>34. Spacer</li> <li>35. Counter 5th gear</li> <li>36. Countershaft rear bearing<br/>Assembly Note ..... page J-51</li> <li>37. Locknut</li> <li>38. Mainshaft rear bearing<br/>Assembly Note ..... page J-51</li> <li>39. Retaining ring</li> <li>40. C-washers</li> <li>41. Thrust washer</li> <li>42. Snap ring</li> <li>43. Bearing housing<br/>Assembly Note ..... page J-52</li> <li>44. 1st/2nd shift rod end<br/>Assembly Note ..... page J-52</li> <li>45. 3rd/4th shift rod end<br/>Assembly Note ..... page J-52</li> <li>46. 5th/Reverse shift rod end<br/>Assembly Note ..... page J-52</li> <li>47. Oil guide</li> </ol> |
|--|---|---|

37U0JX-119

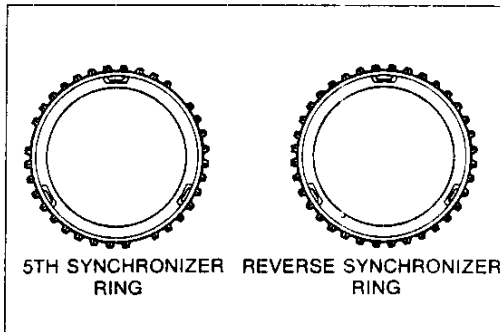

37U0JX-120

### Assembly note Synchronizer ring (5th/Reverse)

The 5th and Reverse synchronizer rings are differentiated as follows.

- (1) The 5th synchronizer ring has 3 places on its circumference with one tooth missing in each place.
- (2) The Reverse synchronizer ring has no distinguishing marks.

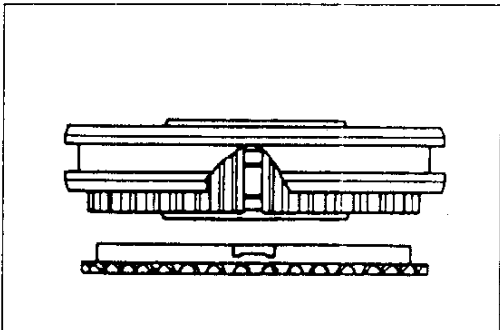

37U0JX-121

### 5th/Reverse clutch hub assembly and locknut

#### Caution

- Align the 5th/Reverse synchronizer grooves with the synchronizer keys.

#### Note

- Standard key dimensions are as follows.

mm {in}

	1	2	3
5th/Reverse	17.00 {0.669}	4.250 {0.167}	5.00 {0.197}

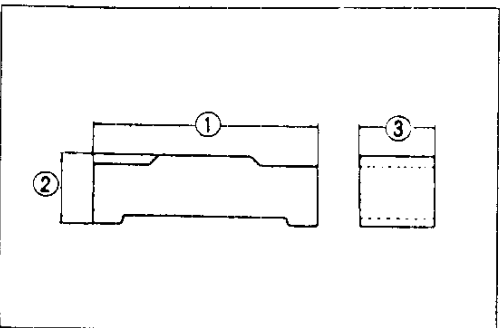

37U0JX-122



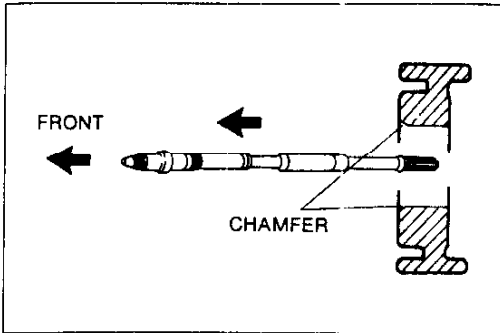

37U0JX-123

**Caution**

- Install the 5th/Reverse clutch hub assembly in the proper direction as shown.

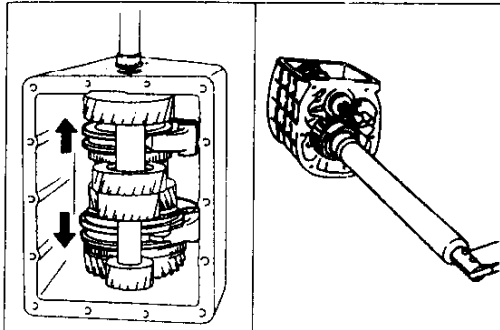

37U0JX-124

1. Shift the clutch hubs into 1st and 4th gears to lock the rotation of the mainshaft.
2. Install a new locknut and tighten it with the SST.

**Tightening torque:**

157–235 N·m {16.0–24.0 kgf·m, 116–173 ft·lbf}

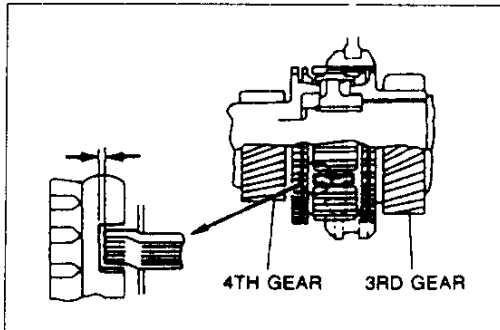

37U0JX-125

**Caution**

- The total combined thickness of the front and rear thrust washers must equal 6.0 mm {0.236 in}.

3. Check the clearance between the synchronizer key and the exposed edge of the synchronizer ring. If it is not as specified, adjust by changing the thrust washers on the front and rear of the mainshaft front bearing.

**Clearance: 0.66–2.0 mm {0.026–0.079 in}**

**Available thrust washer thicknesses:**

2.5 mm {0.098 in}, 3.0 mm {0.118 in}, 3.5 mm {0.138 in}

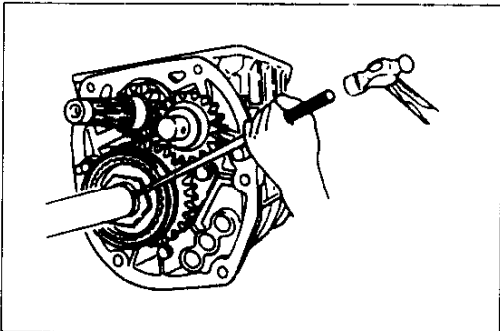

37U0JX-126

4. Stake the locknut into the mainshaft groove.

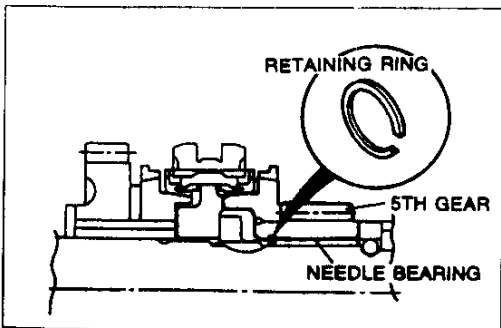

37U0JX-127

**5th gear**

1. Install a new retaining ring to the 5th gear.

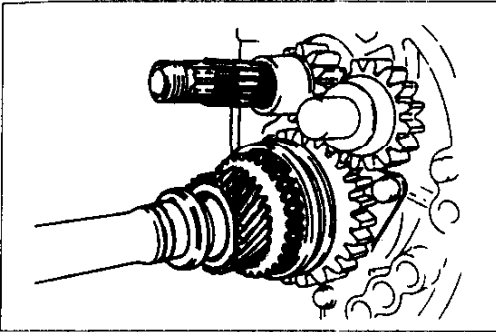

37U0JX-128

2. Install the synchronizer ring, 5th gear, and needle bearing.
3. Install the steel ball and thrust lock washer.
4. Install the 3.0 mm {0.118 in} C-washers and hold them with a retaining ring.

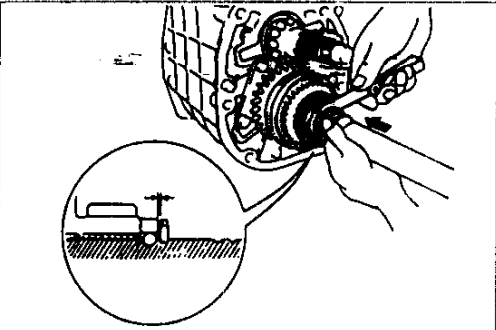

37J0JX-129

5. Push the C-washers toward 5th gear and measure the clearance between the C-washers and thrust lock washer. If the clearance is not as specified, select the proper thrust lock washer.

**Standard: 0.1–0.2 mm {0.004–0.008 in}**

**Available thrust lock washer thicknesses:**

- 6.2 mm {0.244 in}, 6.3 mm {0.248 in}
- 6.4 mm {0.252 in}, 6.5 mm {0.256 in}
- 6.6 mm {0.260 in}, 6.7 mm {0.264 in}

**Shift forks and rods**

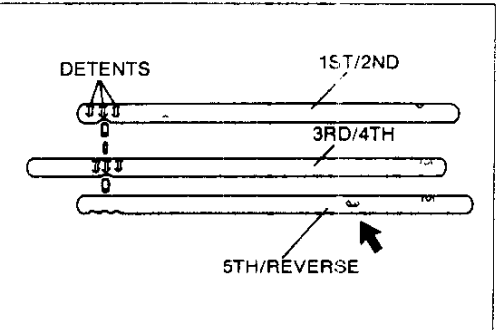

37U0JX-130

**Note**

- A simple way to identify the shift rods is as follows:
- The 3rd/4th shift rod is the longest.
- The 5th/Reverse shift rod has an extra hole for the shift fork roll pin at the rear of the rod.
- When installing the shift rods, set the detents toward the ball side.

**Caution**

- The roll pin must be installed with the split as shown.

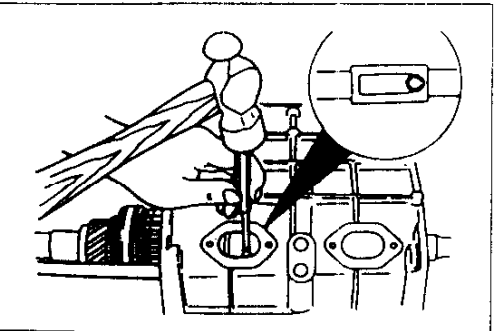

37U0JX-131

1. Slide the 1st/2nd shift rod into the case.
2. Secure the 1st/2nd shift fork to the rod with a new roll pin.

**Note**

- The interlock pins must be installed as shown.

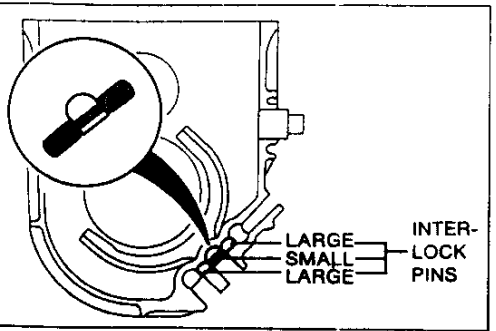

37U0JX-132

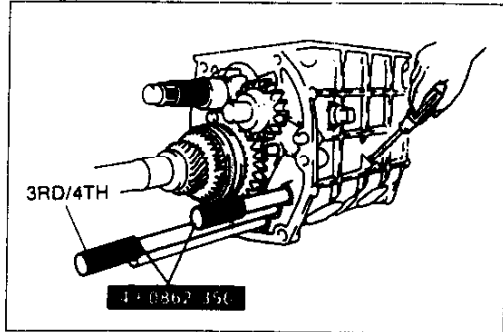

37U0JX-133

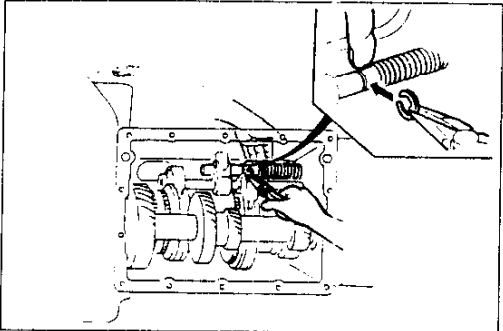

37U0JX-134

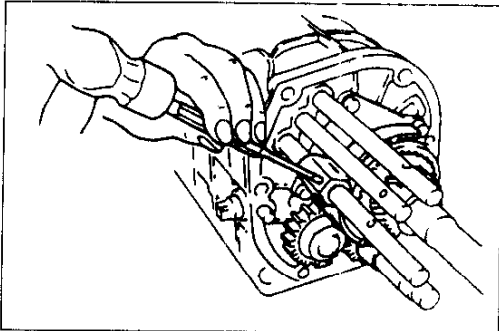

37U0JX-135

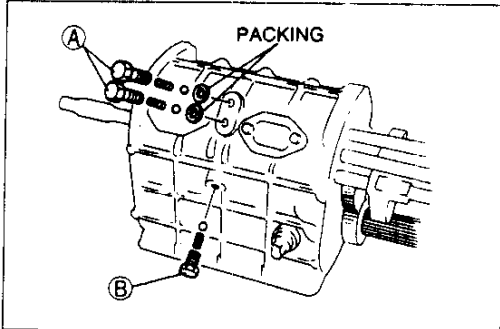

37U0JX-136

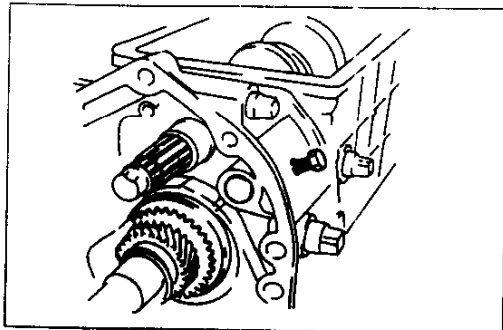

37U0JX-137

3. Slide the two **SST** into the transmission case to guide the interlock pins, and insert the first pin.
4. Remove the 3rd/4th shift fork guide from the case.
5. Slide the 3rd/4th shift rod containing the interlock pin (small) into the case.
6. Secure the 3rd/4th shift rod onto the fork with the new roll pin.
7. Insert the remaining interlock pin and remove the **SST**

8. Install the 5th/Reverse shift fork onto the clutch hub.
9. Install the 5th/Reverse shift rod in the transmission case through the spring.
10. Push back the spring, and install a new clip to the 5th/Reverse shift rod.

11. Install a new roll pin into the 5th/Reverse shift fork.

12. Install the two blind covers and two new gaskets.

**Tightening torque:**

**7.9–10.7 N·m {80–110 kgf·cm, 70–95.4 in·lbf}**

13. Install the packings, detent balls, springs, and cap bolts.

**Tightening torque:**

**A: 40–58 N·m {4.0–6.0 kgf·m, 29–43 ft·lbf}**

**B: 19–25 N·m {1.9–2.6 kgf·m, 14–18 ft·lbf}**

**Center housing**

1. Apply sealant to the contact surfaces of the transmission case and center housing.
2. Install the oil guide.
3. Install the center housing.
4. Align the reverse idler gear shaft with the set bolt hole, and install the set bolt and washer.

**Tightening torque:**

**8.9–13.7 N·m {90–140 kgf·cm, 79–121 in·lbf}**

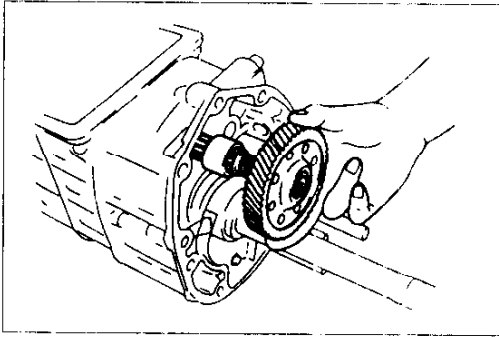

37U0JX 138

5. Install the spacer and counter 5th gear.

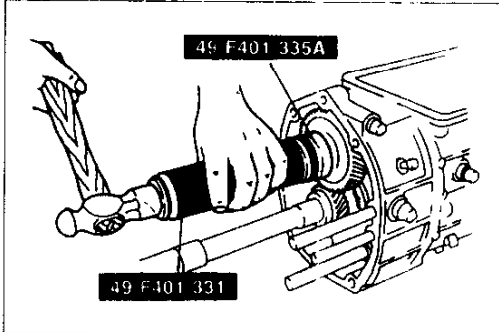

37U0JX 139

**Countershaft rear bearing**

1. Install the countershaft rear bearing by using the **SST**

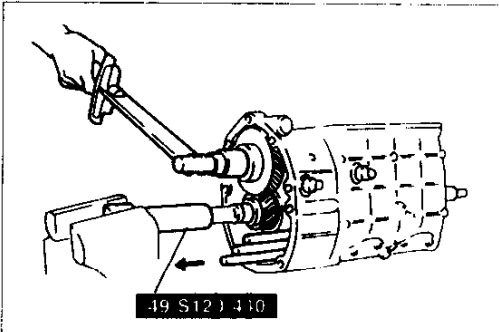

37J0JX 140

2. Connect the **SST** to the mainshaft and mount it securely in a vise.
3. Shift into 1st gear to lock the countershaft.
4. Install the new countershaft locknut.

**Tightening torque:**

**128–196 N·m {13.0–20.0 kgf·m, 95–144 ft·lbf}**

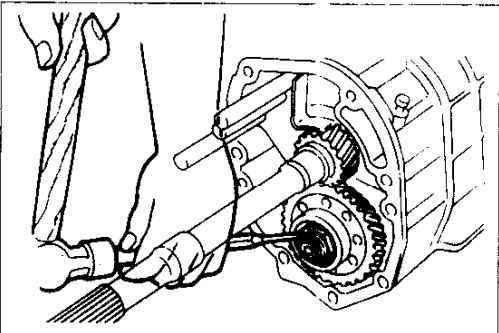

37J0JX 141

5. Stake the locknut into the countershaft groove.

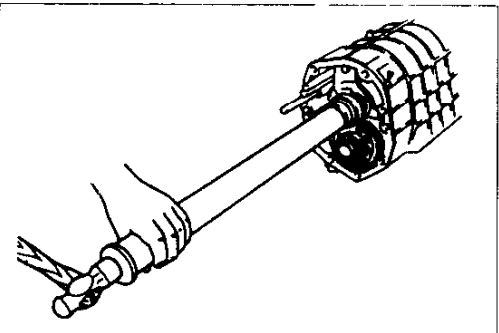

37J0JX 142

**Mainshaft rear bearing**

1. Drive on the mainshaft rear bearing with a suitable pipe

**Bearing diameter (inner): 22 mm {0.87 in}**

**Bearing diameter (outer): 56 mm {2.2 in}**

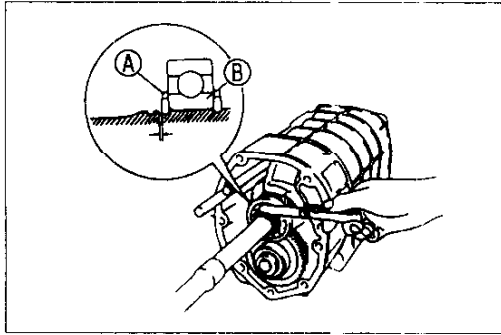

37 J0JX-143

2. Install the C-washers and hold them in place with a new retaining ring.
3. With points A and B pressed tightly together, measure the clearance between the C-washers and the groove. If the clearance is not as specified, select the proper C-washers.

**Standard: 0–0.1 mm {0–0.004 in}**

**Available C-washer thicknesses:**

**2.9 mm {0.114 in}, 3.0 mm {0.118 in}**

**3.1 mm {0.122 in}, 3.2 mm {0.126 in}**

### Bearing housing

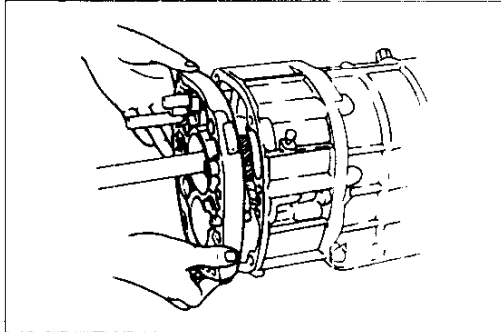

37 J0JX-144

1. Apply sealant to the contact surfaces of the center housing and bearing housing.
2. Install the bearing housing onto the center housing.

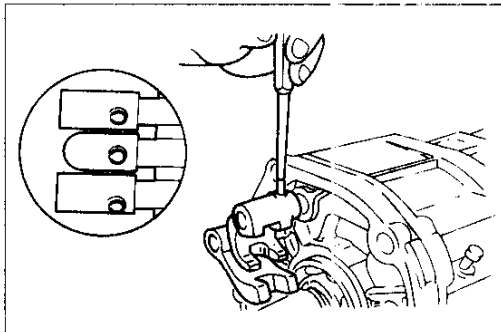

37 J0JX-145

### Shift rod ends

Install the shift rod ends onto the proper shift rods, and secure them with new roll pins facing as shown in the figure.

# TRANSMISSION

J

## Clutch Housing and Extension Housing Components

Assemble in the order shown, referring to **Assembly Note**.

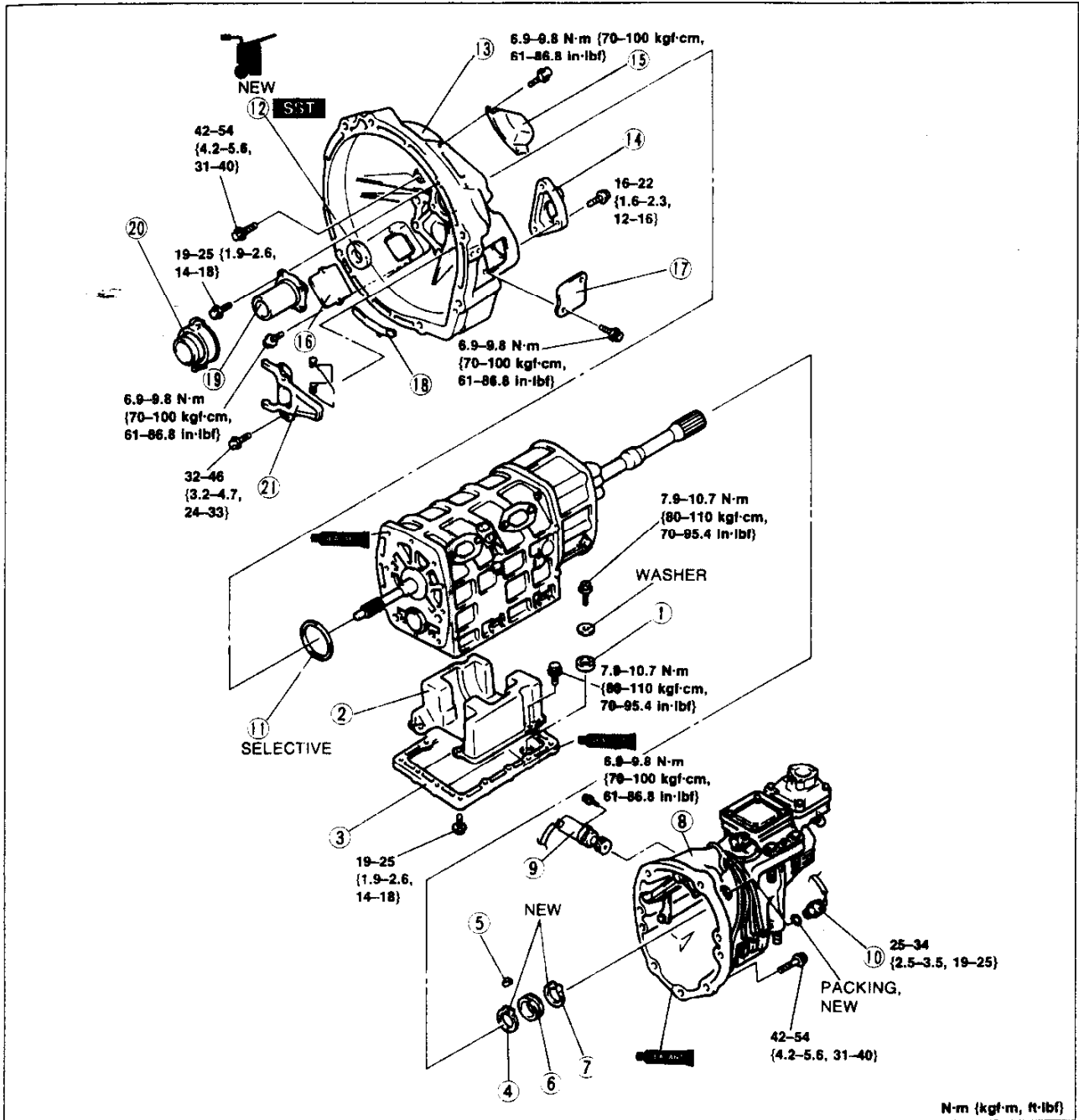

37U0JX-146

- |  |   |   |
|--|---|---|
| 1. Magnet  | 9. Speedometer sensor<br>(Speedometer driven gear)                | 15. Vent cover  |
| 2. Oil baffle  | 10. Back-up light switch  | 16. Service hole B cover                                      |
| 3. Undercover<br>Assembly Note<br>..... page J-54        | 11. Assist shim   | 17. Service hole A cover                                      |
| 4. Snap ring   | 12. Oil seal (clutch housing)<br>Assembly Note<br>..... page J-54 | 18. Dust cover  |
| 5. Key   | 13. Clutch housing<br>Assembly Note<br>..... page J-54            | 19. Front cover   |
| 6. Speedometer drive gear                                | 14. Release cylinder support                                      | 20. Release collar<br>Assembly Note<br>..... page J-55        |
| 7. Snap ring   |   | 21. Release fork assembly<br>Assembly Note<br>..... page J-55 |
| 8. Extension housing<br>Assembly Note<br>..... page J-54 |   |   |

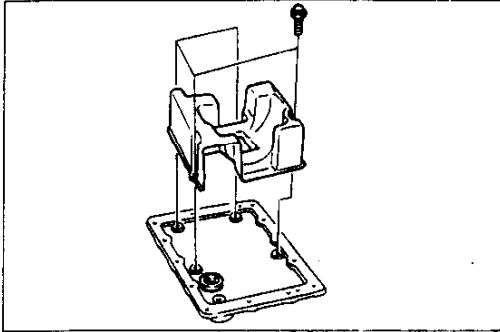

37U0JX-147

**Assembly note**

**Undercover**

1. Install the magnet to the undercover.

**Tightening torque:**

**7.9–10.7 N·m {80–110 kgf·cm, 70–95.4 in·lbf}**

2. Install the oil baffle to the undercover.

**Tightening torque:**

**7.9–10.7 N·m {80–110 kgf·cm, 70–95.4 in·lbf}**

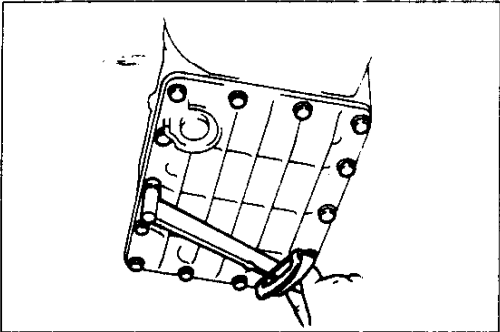

37UCJX-148

3. Apply sealant to the contact surfaces of the undercover and the transmission case.

4. Install the undercover.

**Tightening torque:**

**19–25 N·m {1.9–2.6 kgf·m, 14–18 ft·lbf}**

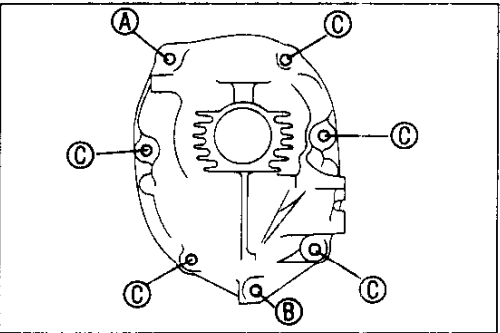

37U0JX-149

**Extension housing**

1. Apply sealant to the contact surfaces of the extension housing and bearing housing.
2. Install the extension housing.

**Bolt length (measured from below the head):**

**A: 135 mm {5.31 in}**

**B: 48 mm {1.89 in}**

**C: 165 mm {6.50 in}**

**Tightening torque:**

**42–54 N·m {4.2–5.6 kgf·m, 31–40 ft·lbf}**

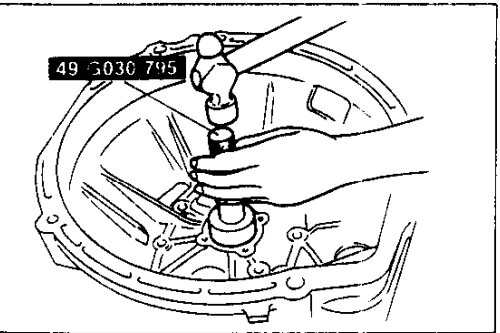

37U0JX-150

**Oil seal (clutch housing)**

1. Apply the specified oil to the lip of a new oil seal.
2. Install the oil seal evenly by using the **SST**.

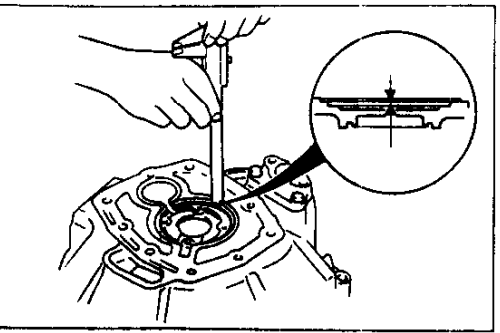

37U0JX-151

**Clutch housing**

1. Measure the depth of the main drive gear bearing bore in the clutch housing by using vernier calipers.

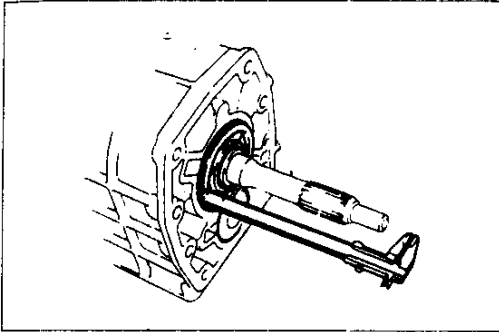

37UCJX-152

**Caution**

● **Make the following measurement after assembling the transmission case.**

2. Measure the main drive gear bearing height.
3. The difference between the measurements in steps 1 and 2 indicates the required thickness of the adjustment shim.

**Standard thrust play: 0–0.1 mm {0–0.004 in}**

**Adjustment shim thicknesses:**

**0.3 mm {0.012 in}, 0.4 mm {0.016 in}**

**0.5 mm {0.020 in}, 0.6 mm {0.024 in}**

**0.7 mm {0.028 in}**

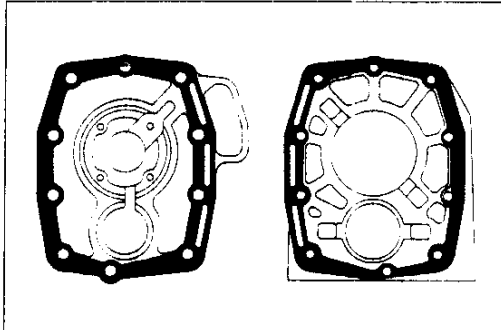

37U0JX-153

4. Apply sealant to the contact surfaces of the clutch housing and transmission case.
5. Install the correct adjustment shim on the main drive gear bearing as determined in steps 1 and 2.

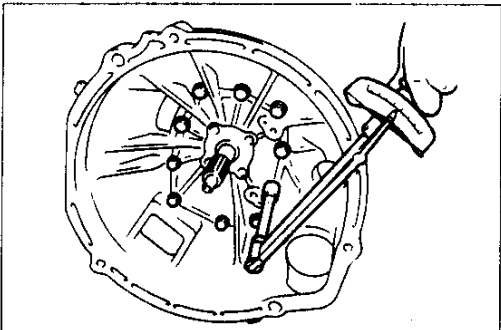

37U0JX-154

6. Install the clutch housing.

**Tightening torque:**

**42–54 N·m {4.2–5.6 kgf·m, 31–40 ft·lbf}**

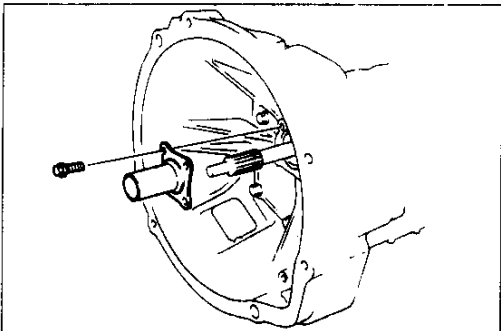

37U0JX-155

7. Install the front cover to the clutch housing.

**Tightening torque:**

**19–25 N·m {1.9–2.6 kgf·m, 14–18 ft·lbf}**

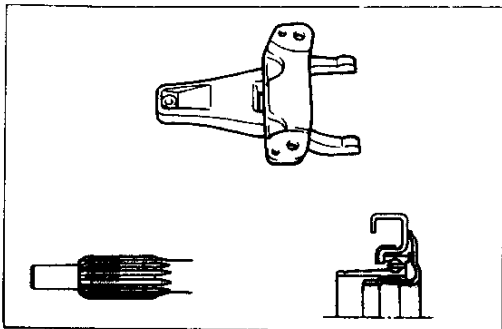

37U0JX-156

**Release collar and release fork assembly**

1. Apply molybdenum grease to the shaded areas of the release bearing and release fork.



# J

## TRANSMISSION

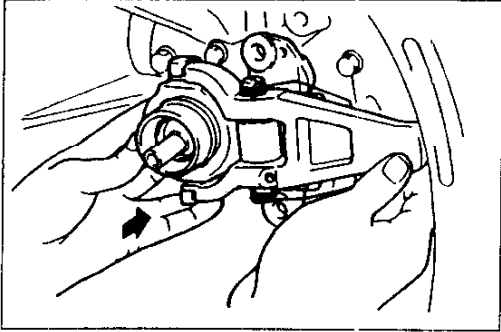

37U0JX-157

2. Install the release bearing and release fork assembly.

**Tightening torque:**

**32–46 N·m {3.2–4.7 kgf·m, 24–33 ft·lbf}**

# TRANSMISSION

J

## INSTALLATION

1. Install in the order shown, referring to **Installation Note**.
2. After installation, fill the transmission with the specified oil and do a road test.

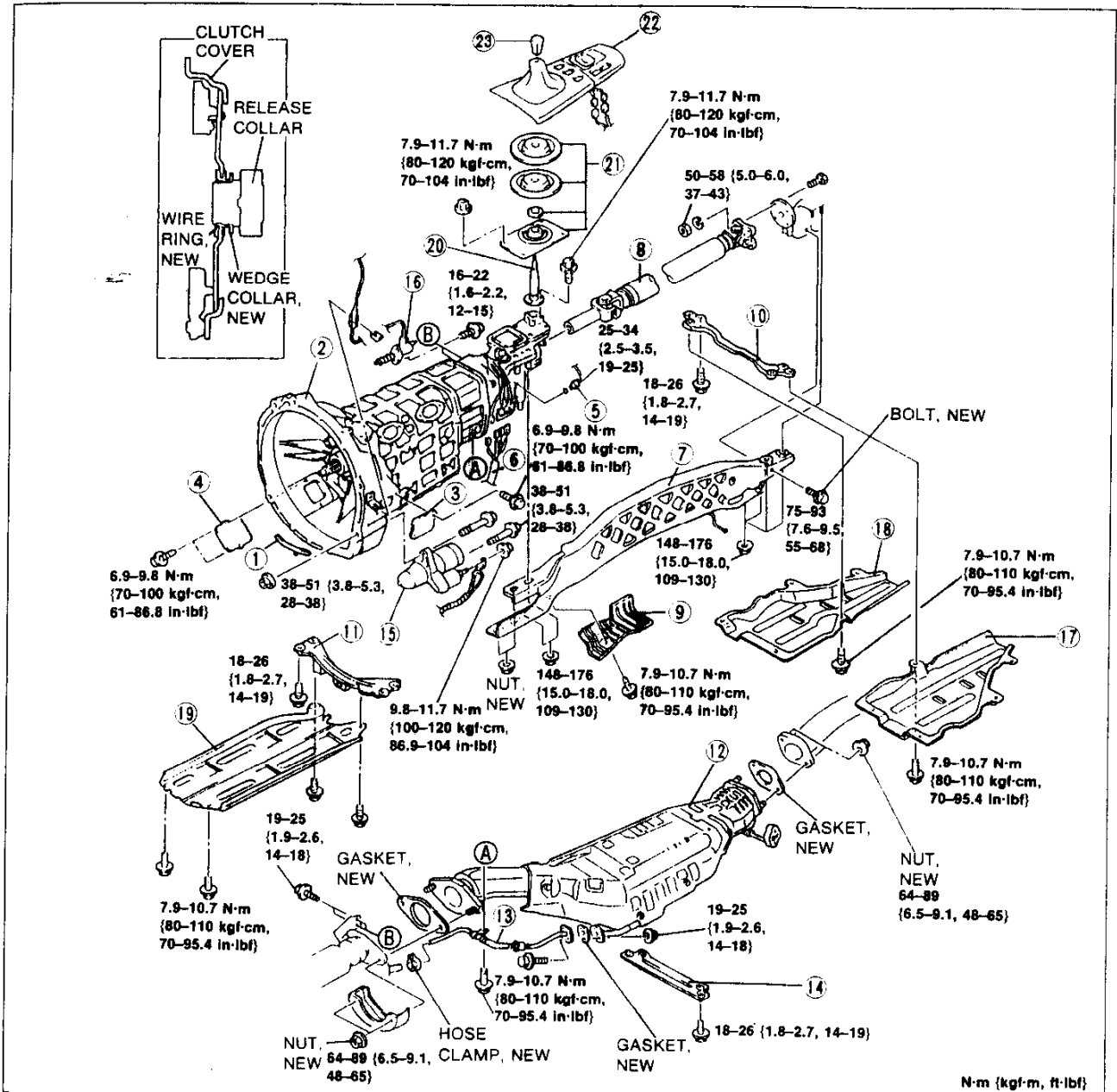

37U0JX-158

- |                            |                             |                             |
|----------------------------|-----------------------------|-----------------------------|
| 1. Dust cover              | 8. Propeller shaft          | 14. Tunnel reinforcement    |
| 2. Transmission            | Installation Note           | (center)                    |
| Installation Note          | ..... page J-60             | 15. Starter                 |
| ..... page J-58            |                             | 16. Clutch release cylinder |
| 3. Service hole A cover    | 9. Cover                    | 17. Left undercover         |
| 4. Service hole B cover    | 10. Tunnel reinforcement    | 18. Right undercover        |
| 5. Back-up light switch    | (rear)                      | 19. Transmission cover      |
| 6. Connectors              | 11. Tunnel reinforcement    | 20. Shift lever assembly    |
| 7. Power Plant Frame (PPF) | (front)                     | 21. Insulator assembly      |
| Installation Note          | 12. Catalytic converter     | 22. Console panel assembly  |
| ..... page J-59            | assembly                    | 23. Shift lever knob        |
|                            | 13. Secondary air injection |                             |
|                            | pipe                        |                             |

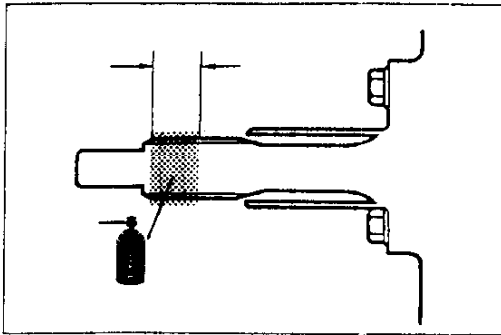

37U0JX-159

### Installation Note Transmission

#### Caution

- Do not install the back-up light switch until after the transmission is installed.

1. Coat the main drive gear splines with grease as shown in the figure.

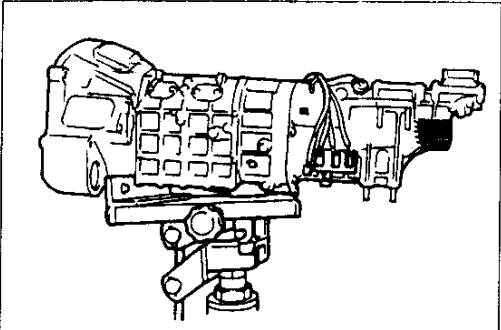

37U0JX-160

#### Warning

- Do not allow the transmission to fall from the jack.

2. Set the transmission on a transmission jack.

#### Caution

- Do not damage the wedge collar when installing the transmission to the engine.
- Do not damage the harnesses, clutch pipe, or clutch release cylinder.

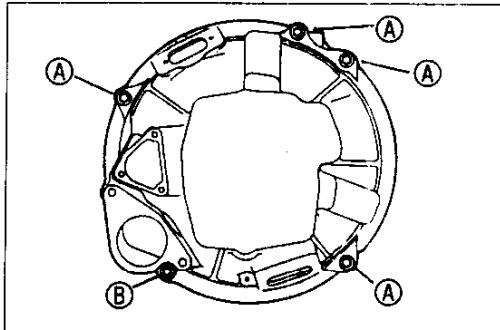

37U0JX-161

3. Raise the transmission into place and install it to the engine.

4. Tighten the installation bolts.

#### Bolt length:

A: 55 mm {2.2 in}

B: 90 mm {3.5 in}

#### Tightening torque:

38–51 N·m {3.8–5.3 kgf·m, 28–38 ft·lbf}

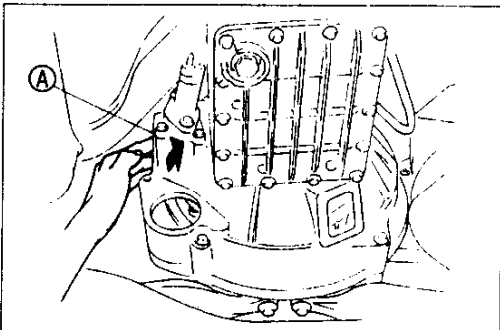

37U0JX-162

#### Caution

- Make sure that the clutch release collar snaps properly into the clutch cover.

5. Through service hole A, push the release-cylinder end of the clutch release fork toward the transmission, and connect the clutch release collar to the clutch cover.

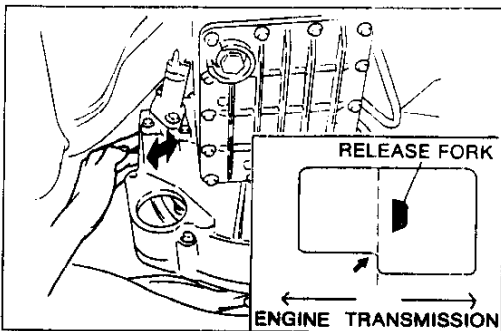

37U0JX-174

6. Swing the clutch release fork back and forth to verify that the clutch release collar is connected to the clutch cover.

7. Push the release-cylinder end of the clutch release fork toward the engine, and verify that it does not move past the dotted line.

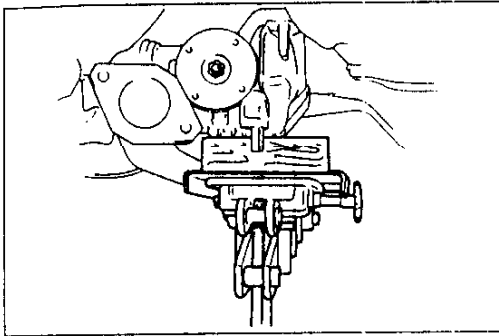

37U0JX-163

**Power plant frame (PPF)**

**Caution**

- Do not reuse PPF installation nuts.

1. Hold the differential at a 0° angle by using the transmission jack.

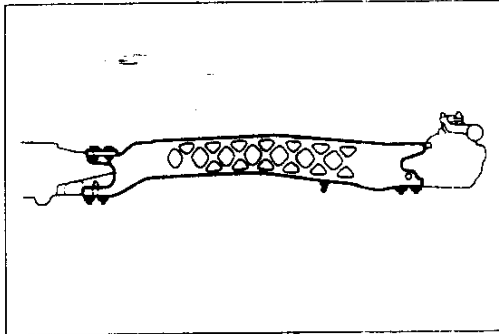

37U0JX-164

2. Hold the PPF in place with a new bolt and 8 new nuts.

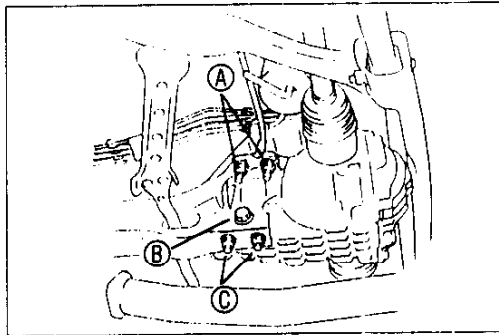

37U0JX-165

**Caution**

- Tighten the differential-side PPF installation bolt/nuts first.

3. Tighten the differential-side PPF installation bolt and nuts in the order shown.

**Tightening torque:**

- A, C: 148–176 N·m {15.0–18.0 kgf·m, 109–130 ft·lbf}
- B: 75–93 N·m {7.6–9.5 kgf·m, 55–68 ft·lbf}

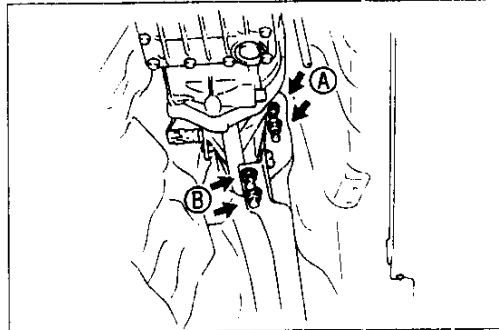

37U0JX-166

4. Tighten the transmission-side PPF installation nuts in the order shown.

**Tightening torque:**

- 148–176 N·m {15.0–18.0 kgf·m, 109–130 ft·lbf}

5. Remove the transmission jack.

6. Lower the vehicle to the ground, and remove the SST (engine supports).

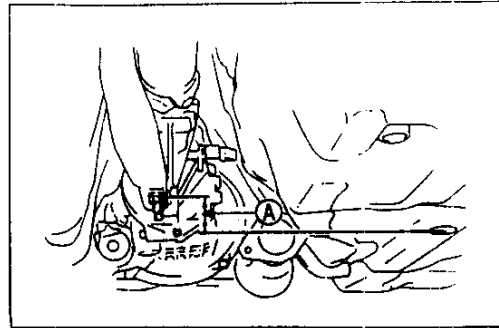

37U0JX-167

7. Measure A as shown in the figure.

**Standard:**

- Right: 73 mm {2.9 in} min.
- Left : 75 mm {3.0 in} min.

**Note**

- When measuring by using a straight edge placed on both the right and left sides, the clearance should be 74.0 mm {2.91 in} minimum.

8. If outside the standard, readjust the PPF.

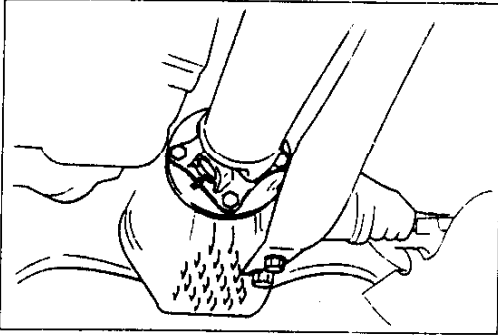

37U0.JX.168

**Propeller shaft**

1. Align the marks on the flanges (made during removal).
2. Install the propeller shaft.

**Tightening torque:****50–58 N·m {5.0–6.0 kgf·m, 37–43 ft·lbf}**

SHIFT MECHANISM

OVERHAUL

1. Disassemble as shown in the figure.
2. Inspect each part, and replace if necessary.
3. Assemble in the reverse order of disassembly.
4. After assembly, pump the clutch pedal and verify that the shift lever moves smoothly.

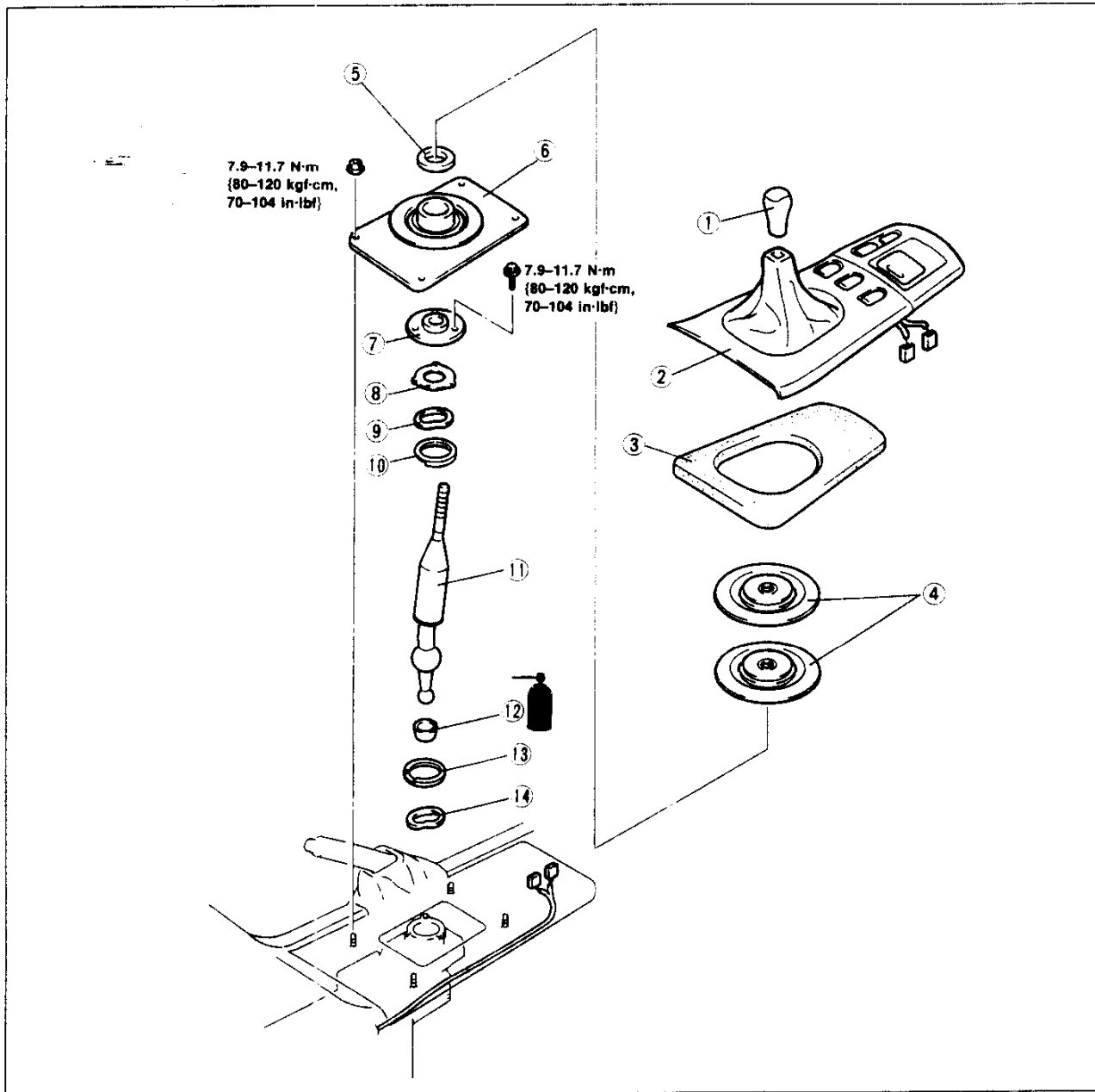

37U0JX-169

- |                           |                 |                 |
|---------------------------|-----------------|-----------------|
| 1. Shift lever knob       | 8. Gasket       | 12. Shift seat  |
| 2. Console panel assembly | 9. Wave washer  | Assembly Note   |
| 3. Bushing pad            | 10. Bushing     | ..... page J-62 |
| 4. Insulator boot pads    | 11. Shift lever | 13. Bushing     |
| 5. Insulator boot ring    | Assembly Note   | 14. Wave washer |
| 6. Insulator boot         | ..... page J-62 |                 |
| 7. Dust boot              |                 |                 |

# J

## SHIFT MECHANISM

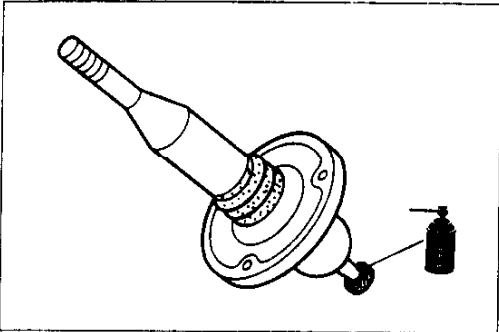

37U0JX-170

### Assembly Note Shift seat

Apply grease to both the inside and outside of the shift seat.

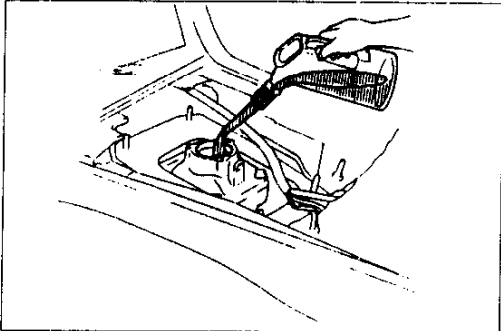

37U0JX-171

### Shift lever

#### Note

- Fill the change control case with oil after removing the clutch housing or disassembling the transmission.

1. Fill the change control case with the specified oil.

**Capacity: 80–95 cc {4.9–5.8 cu in}**

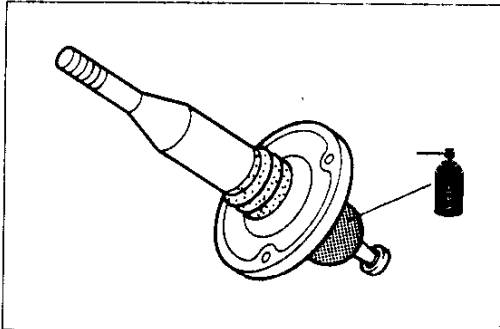

37U0JX-172

2. Apply grease to the shift lever ball joint.

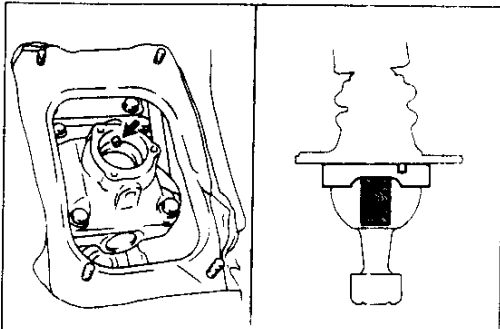

37U0JX-173

3. Align the control case pin with the slots in the change bushings and the shift lever, and install.