

This file is available for free download at <http://www.iluvmyrx7.com>

This file is fully text-searchable – select Edit and Find and type in what you're looking for. This file is intended more for online viewing than printing out so some graphics may not print 100% legibly, you can zoom in on them if you need to.



[www.iluvmyrx7.com](http://www.iluvmyrx7.com)

# WIRING DIAGRAM SYMBOLS

## Article Text

1983 Mazda RX7

For [www.iluvmyrx7.com](http://www.iluvmyrx7.com)

Copyright © 1998 Mitchell Repair Information Company, LLC  
Saturday, September 08, 2001 10:05AM

## ARTICLE BEGINNING

WIRING DIAGRAMS

How To Use The Wiring Diagrams

## WIRING DIAGRAMS

### INTRODUCTION

The wiring diagrams and technical service bulletins, containing wiring diagram changes, are obtained from the domestic and import manufacturers. These are checked for accuracy and are all redrawn into a consistent format for easy use.

All diagrams are arranged with the front of the vehicle at the left side of the first page and the rear of the vehicle at the right side of the last page. Accessories are shown near the end of the diagram.

Components are shown in their approximate location on the vehicle. Due to the constantly increasing number of components on vehicles today, it is impossible to show exact locations.

In the past, when cars were simpler, diagrams were simpler. All components were connected by wires, and diagrams seldom exceeded 4 pages in length. Today some wiring diagrams require more than 16 pages. It would be impractical to expect a service technician to trace a wire from page 1 across every page to page 16.

Removing some of the wiring maze reduces eyestrain and time wasted searching across several pages. Today, the majority of diagrams now follow a much improved format, which permits space for internal switch details and connector shapes.

Any wires that don't connect directly to their components are identified on the diagram to indicate where they go. There is a legend on the first page of each diagram, detailing component location. It refers you to sub-systems, using grid NUMBERS at the top and bottom of the page and grid LETTERS on each side. This grid system works in a manner similar to that of a road map.

### HOW TO USE THE WIRING DIAGRAMS

1) On the first page of the diagram, you will find a listing of major electrical components or systems. Locate the specific component or system you wish to trace. A grid number and letter will follow the component's name.

2) Use the grid NUMBERS (arranged horizontally across the top and bottom of each page) to find the page of the wiring diagram that contains the component you're seeking. When you reach this page, use the grid LETTERS on the side of the page to determine the component's vertical location.

3) Locate the circuit you need to service. The internals are shown for switches and relays to assist you in understanding how the circuit operates.

NOTE: In some of the newer wiring diagram articles in this

# WIRING DIAGRAM SYMBOLS

## Article Text (p. 2)

1983 Mazda RX7

For www.iluvmyrx7.com

Copyright © 1998 Mitchell Repair Information Company, LLC

Saturday, September 08, 2001 10:05AM

product, there is a Legend for the wiring diagrams that has been created to make locating components easier. For these articles, there will be a COMPONENT LOCATION MENU title in the article main menu. These articles will also have the original legend available on the first graphic.

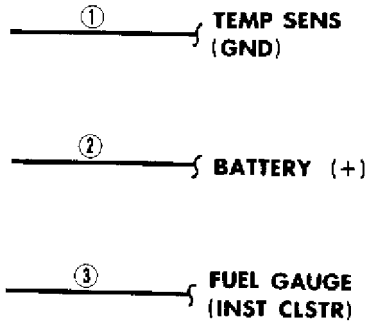

Fig. 1: Identifying Tie-Off Symbols

4) If the wires are not drawn all the way to another component (across several pages), a reference will tell you their final destination.

5) Again, use the legend on the first page of the wiring diagram to determine the grid number and letter of the referenced component. You can then turn directly to it without tracing wires across several pages.

6) The symbols shown in Fig. 1 are called tie-offs. The first tie-off shown indicates that the circuit goes to the temperature sensor, and is also a ground circuit.

7) The second symbol indicates that the circuit goes to a battery positive parallel circuit. The third symbol leads to a particular component and the location is also given.

8) The lines shown in Fig. 2 are called options. Which path or option to take depends on what engine or systems the vehicle has.

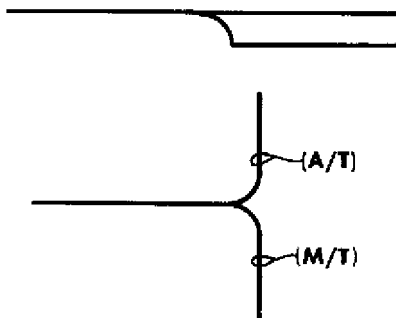

Fig. 2: Identifying Option Symbols

### COLOR ABBREVIATIONS IDENTIFICATION

#### COLOR ABBREVIATIONS

AA

Color	Normal	Optional
-------	--------	----------

Black	..... BLK	..... BK
-------	-----------	----------

# WIRING DIAGRAM SYMBOLS

## Article Text (p. 3)

1983 Mazda RX7

For www.iluvmyrx7.com

Copyright © 1998 Mitchell Repair Information Company, LLC

Saturday, September 08, 2001 10:05AM

Blue	.....	BLU	.....	BU
Brown	.....	BRN	.....	BN
Clear	.....	CLR	.....	CR
Dark Blue	.....	DK BLU	.....	DK BU
Dark Green	.....	DK GRN	.....	DK GN
Green	.....	GRN	.....	GN
Gray	.....	GRY	.....	GY
Light Blue	.....	LT BLU	.....	LT BU
Light Green	.....	LT GRN	.....	LT GN
Orange	.....	ORG	.....	OG
Pink	.....	PNK	.....	PK
Purple	.....	PPL	.....	PL
Red	.....	RED	.....	RD
Tan	.....	TAN	.....	TN
Voilet	.....	VIO	.....	VI
White	.....	WHT	.....	WT
Yellow	.....	YEL	.....	YL

AA

### WIRING DIAGRAM SYMBOL IDENTIFICATION

NOTE: Standard wiring symbols are used on diagrams. The list below will help clarify any symbols that are not easily understood at a glance. Most components are labeled "Motor", "Switch" or "Relay" in addition to being drawn with the standard symbol.

### WIRING DIAGRAM SYMBOLS

Views of the symbols used in the WIRING DIAGRAM articles are in the following graphics. See Figs. 3 through 25.



Fig. 3: Circuit Breaker

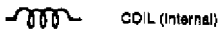

Fig. 4: Coil (Internal)



Fig. 5: Connector

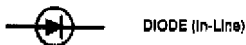

Fig. 6: Diode (In-Line)



Fig. 7: Diode (Internal)

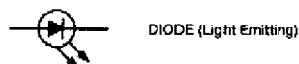

Fig. 8: Diode (Light Emitting)

# WIRING DIAGRAM SYMBOLS

## Article Text (p. 4)

1983 Mazda RX7

For [www.iluvmyrx7.com](http://www.iluvmyrx7.com)

Copyright © 1998 Mitchell Repair Information Company, LLC  
Saturday, September 08, 2001 10:05AM



Fig. 9: Defogger Grid



Fig. 10: Fuse



Fig. 11: Fusible Link



Fig. 12: Ground

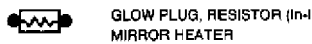

Fig. 13: Glow Plug Resistor (In-Line) or Mirror Heater



Fig. 14: Injector (Diesel) or Photocell (Gasoline)

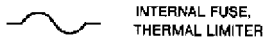

Fig. 15: Internal Fuse, Thermal Limiter



Fig. 16: Lamp (Dual Element)



Fig. 17: Lamp (Single Element)



Fig. 18: Motor



Fig. 19: Resistor (Internal)



Fig. 20: Sensor, Thermistor

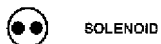

Fig. 21: Solenoid



Fig. 22: Solid State Device, Transistor



Fig. 23: Switch (Internal)

## WIRING DIAGRAM SYMBOLS

### Article Text (p. 5)

1983 Mazda RX7

For [www.iluvmyrx7.com](http://www.iluvmyrx7.com)

Copyright © 1998 Mitchell Repair Information Company, LLC  
Saturday, September 08, 2001 10:05AM



TWO PIN SWITCH

Fig. 24: Two Pin Switch



VARIABLE RESISTOR  
OR POTENTIOMETER

Fig. 25: Variable Resistor or Potentiometer

**END OF ARTICLE**

**WIRING DIAGRAMS**  
**Article Text**  
1983 Mazda RX7  
For [www.iluvmyrx7.com](http://www.iluvmyrx7.com)  
Copyright © 1998 Mitchell Repair Information Company, LLC  
Saturday, September 08, 2001 10:05AM

**ARTICLE BEGINNING**

1983 Wiring Diagrams  
Mazda  
  
RX7

**IDENTIFICATION**

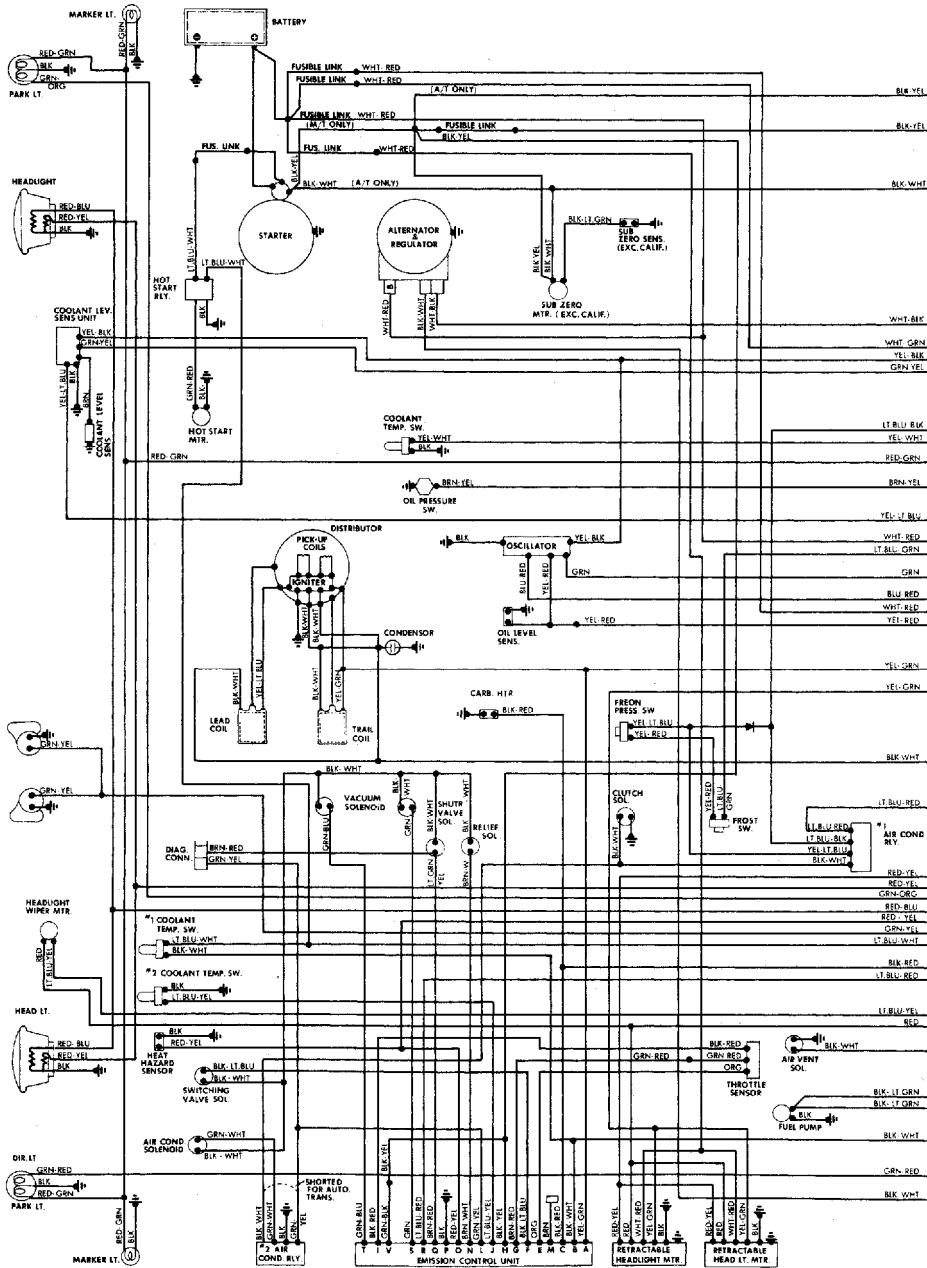

96119  
Fig. 1: Engine Compartment

**WIRING DIAGRAMS**  
**Article Text (p. 2)**  
 1983 Mazda RX7  
 For www.iluvmyrx7.com  
 Copyright © 1998 Mitchell Repair Information Company, LLC  
 Saturday, September 08, 2001 10:05AM

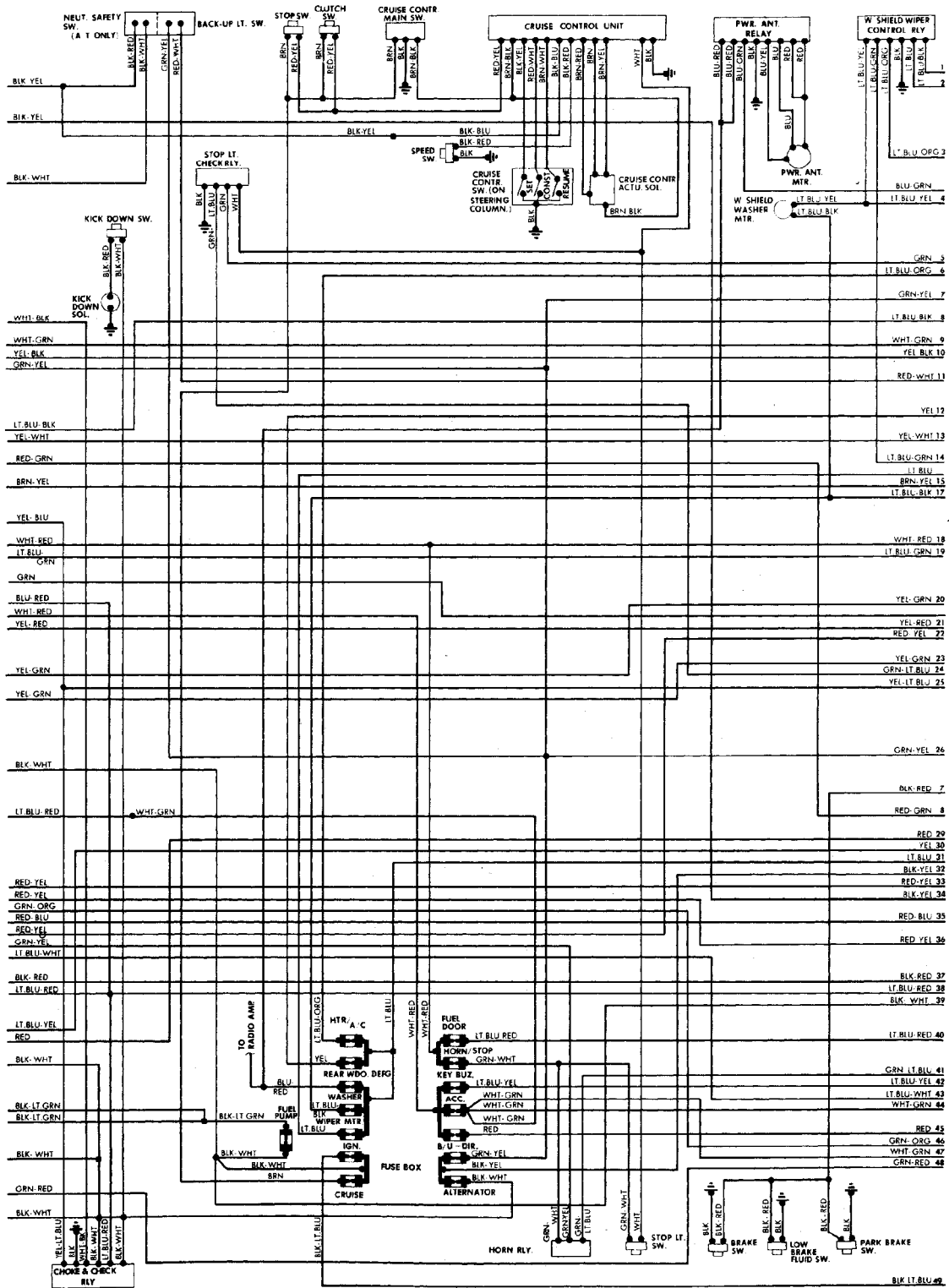

96120  
 Fig. 2: Fuse Block & Underdash



# WIRING DIAGRAMS

## Article Text (p. 3)

### 1983 Mazda RX7

For [www.iluvmyrx7.com](http://www.iluvmyrx7.com)  
 Copyright © 1998 Mitchell Repair Information Company, LLC  
 Saturday, September 08, 2001 10:05AM

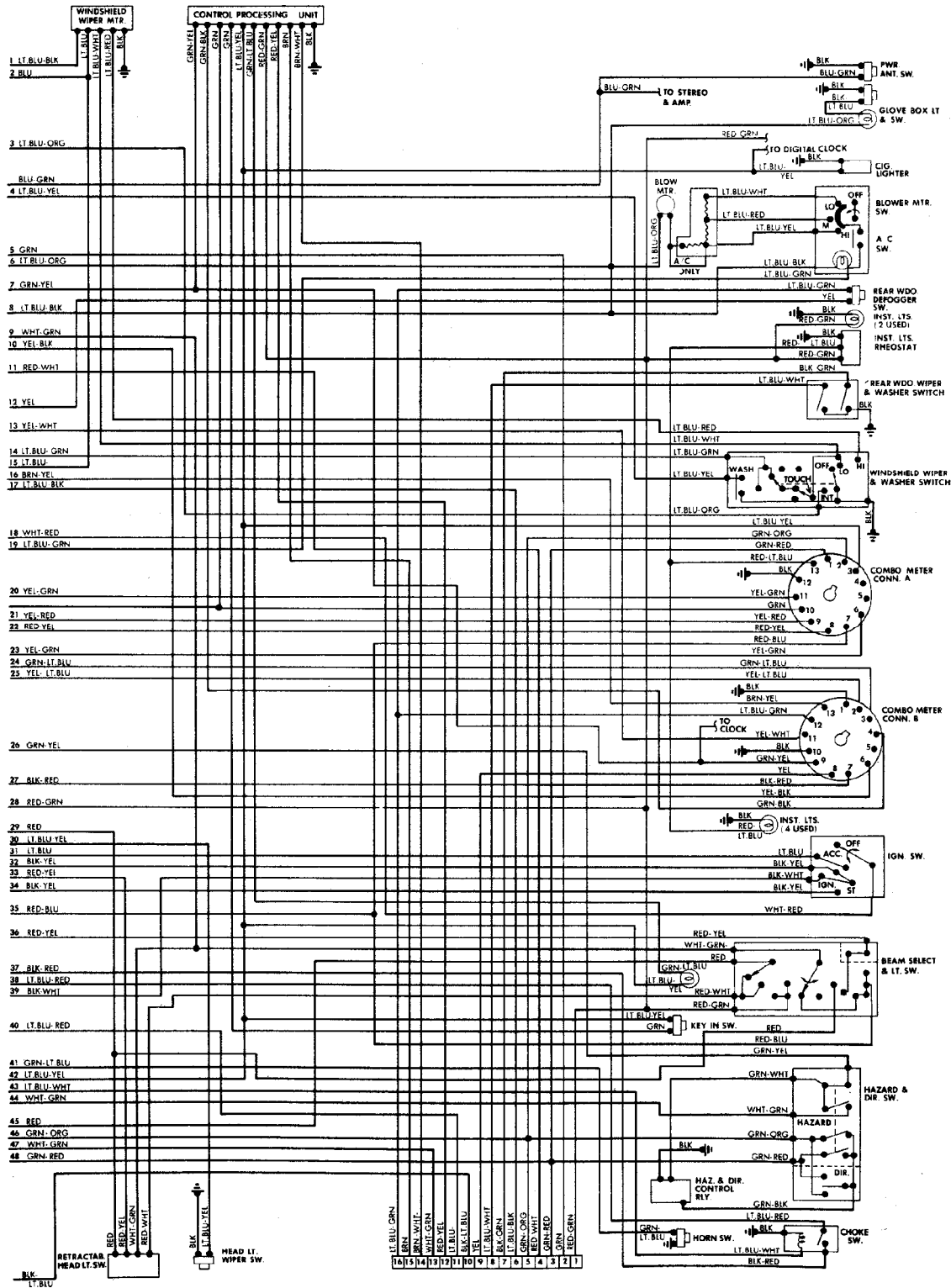

96121  
 Fig. 3: Underdash (Cont.) & Instrument Panel

**WIRING DIAGRAMS**  
**Article Text (p. 4)**  
 1983 Mazda RX7  
 For www.iluvmyrx7.com  
 Copyright © 1998 Mitchell Repair Information Company, LLC  
 Saturday, September 08, 2001 10:05AM

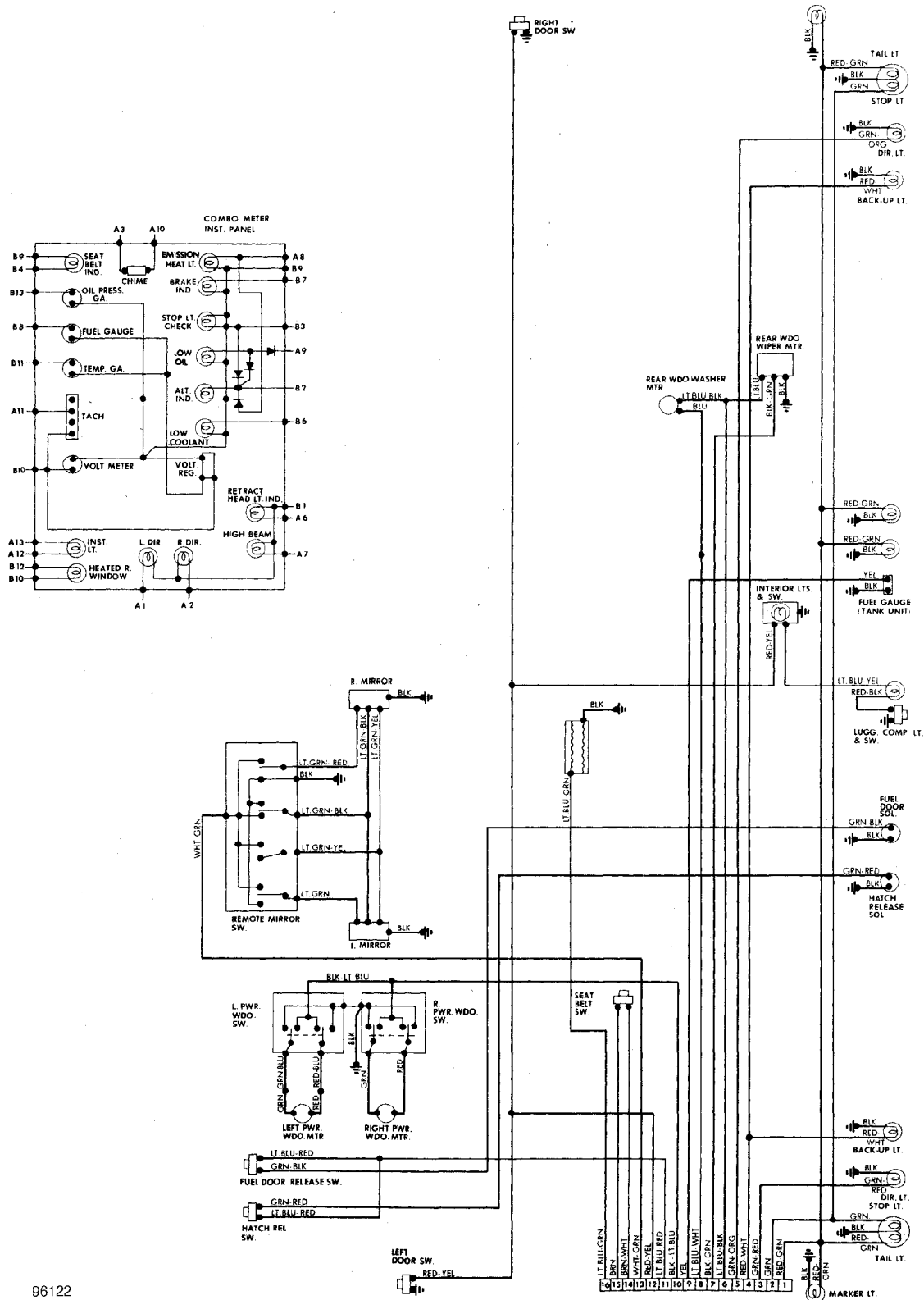

96122

Fig. 4: Rear Compartment & Accessories

END OF ARTICLE