

This file is available for free download at <http://www.iluvmyrx7.com>



www.iluvmyrx7.com

0900 -1 KEY SETS

0900 KEY SETS

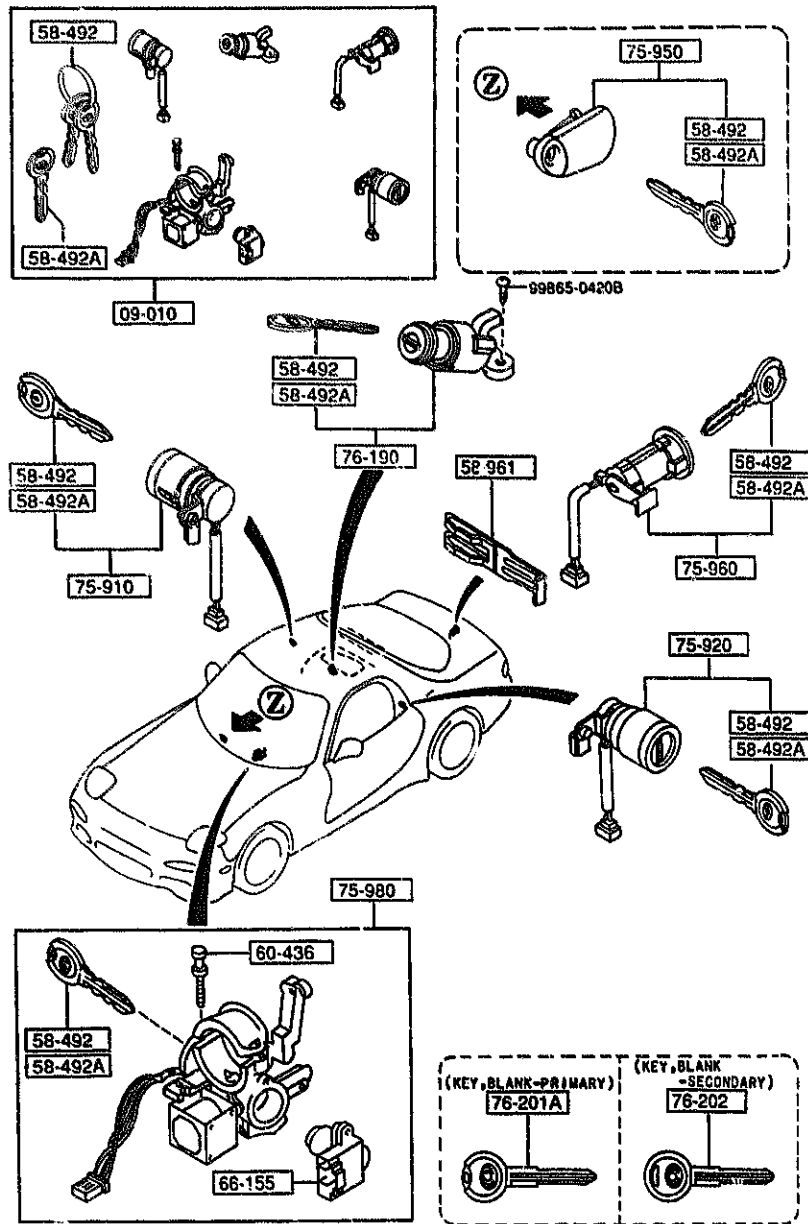

PART NO.	QTY	MODEL/RESTRICTION	MODEL/RESTRICTION	MODEL/RESTRICTION	FROM-TO
09-010		KEY SET			
FD15-09-010B	1	(MT)			
FD17-09-010B	1	(AT)			
58-492		KEY, PRIMARY			
FD01-58-492	2	KEY NO. IS REQUIRED			
58-492A		KEY, SECONDARY			
FD01-58-493	1	KEY NO. IS REQUIRED			
58-961		FASTENER, KEY CYL.			
BJ21-56-902A	1				
60-436		BOLT, SET			
H043-66-154	2				
66-155		SWITCH, IGNITION			
FD01-66-151	1				
75-910		KEY SUB SET(R), DOOR			
FD01-76-210B	1				
75-920		KEY SUB SET(L), DOOR			
FD01-76-220B	1				
75-950		KEY SUB SET, GLOVE			
FD15-76-250	1				
75-960		KEY SUB SET, LIFT GATE			
FD01-76-260	1				
75-980		KEY SUB SET, IG. SWICH			
FD01-76-290	1	(MT)			
FD02-76-290	1	(AT)			
76-190		KEY SUB SET, STOWAGE			
FD01-76-190	1				
76-201A		KEY, BLANK-PRIMARY			

AUFA05

CAT. AUFA05-03

1995-03

0900 KEY SETS

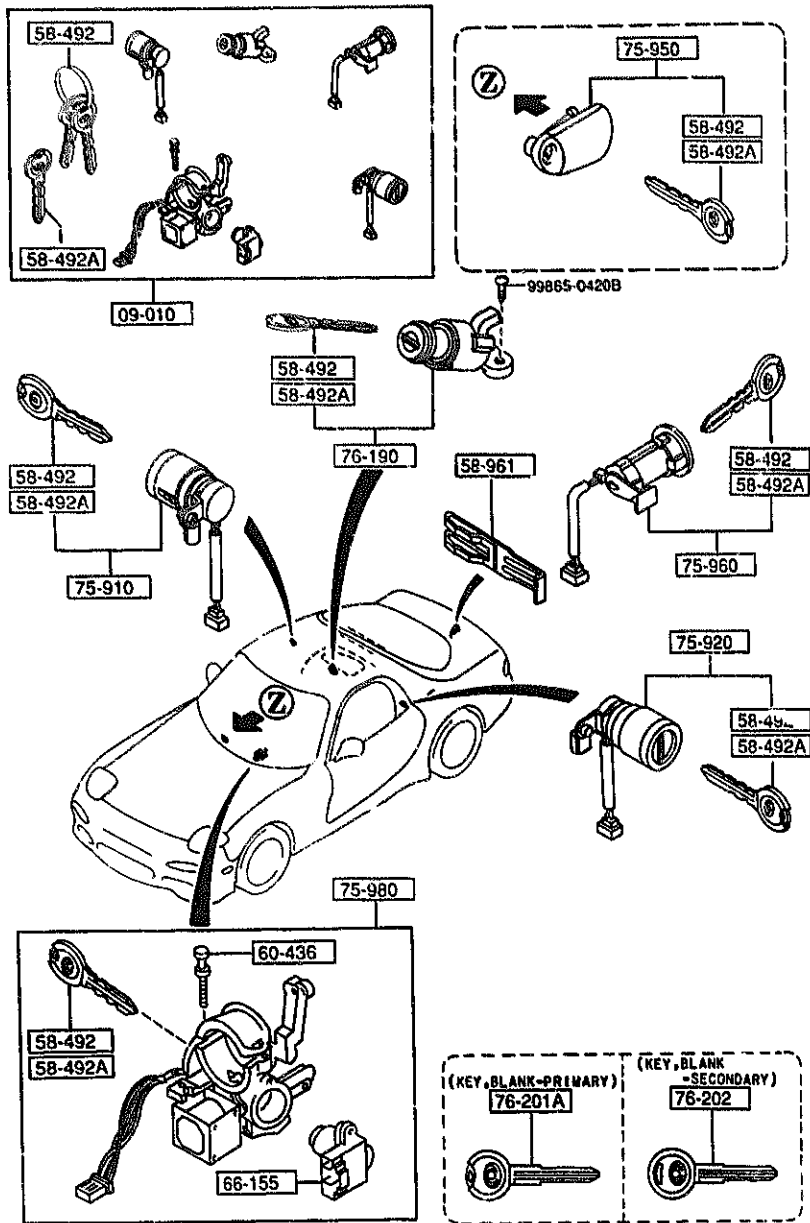

PART NO.	QTY	MODEL/RESTRICTION	MODEL/RESTRICTION	MODEL/RESTRICTION	FROM TO
CONT'D FD01-76-201	1				
		↑ 76-202 ↓			
FD01-76-202	1	KEY, BLANK-SECONDARY			

AUFA05

CAY AUFA05-03

1995-03

5000 -1 FRONT BUMPER

5000 FRONT BUMPER

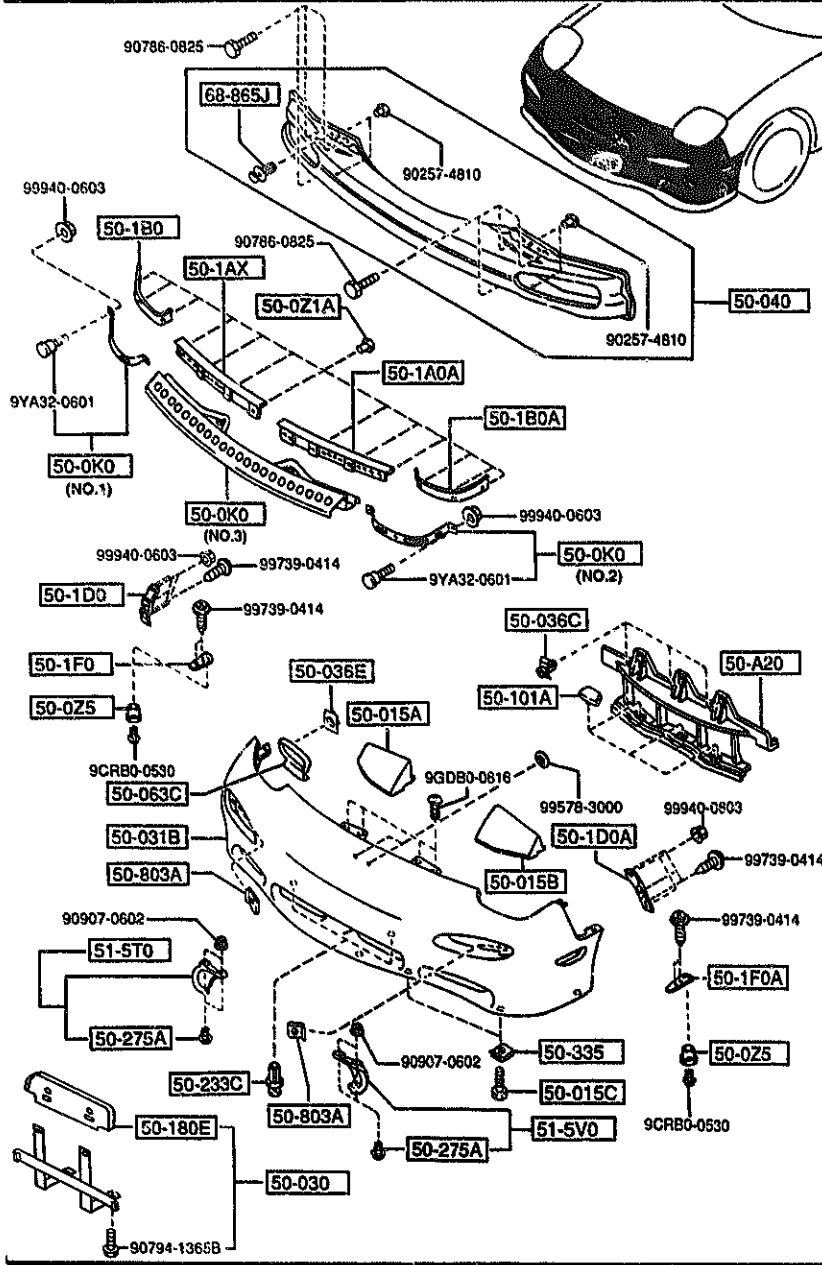

PAF NO.	QTY	MODEL/RESTRICTION	MODEL/RESTRICTION	MODEL/RESTRICTION	FROM-TO
50-A20		GUIDE, AIR			
FD01-50-A21	1				
50-0K0		RETAINER, FASCIA			
FD01-50-0KXA	1	(ILLUST. NO.1)			
FD01-50-0K0A	1	(ILLUST. NO.2)			
FD01-50-0K1B	1	(ILLUST. NO.3)			
50-0Z1A		RIVET, BLIND			
BR70-50-0Z1	13				
50-0Z5		GROMMET, SCREW			
FD01-50-0Z5	2				
50-015A		SPACER			
FD01-50-CR0	1				
50-015B		SPACER			
FD01-50-CS0	1				
50-015C		BOLT			
BR70-50-0Z2	4				
50-030		HOLDER, NO. PLATE			
FD01-50-170B	1				
50-031B		FACE, FRONT BUMPER			
FD01-50-031C	1	PAINT TO MATCH			
50-036C		FASTENER			
BF67-50-033	3				
50-036E		CLIP			
GJ21-50-049	2	((MT))>(NOR. SUSP)			
50-040		REINFORCEMENT, BUMPER			
FD01-50-070B	1				
50-063C		COVER(R), BUMPER			
FD01-51-365	1	((MT))>(NOR. SUSP)			

AUFA05

CAT. AUFA05-03

1995-03

5000 -3 * FRONT BUMPER

5000 FRONT BUMPER

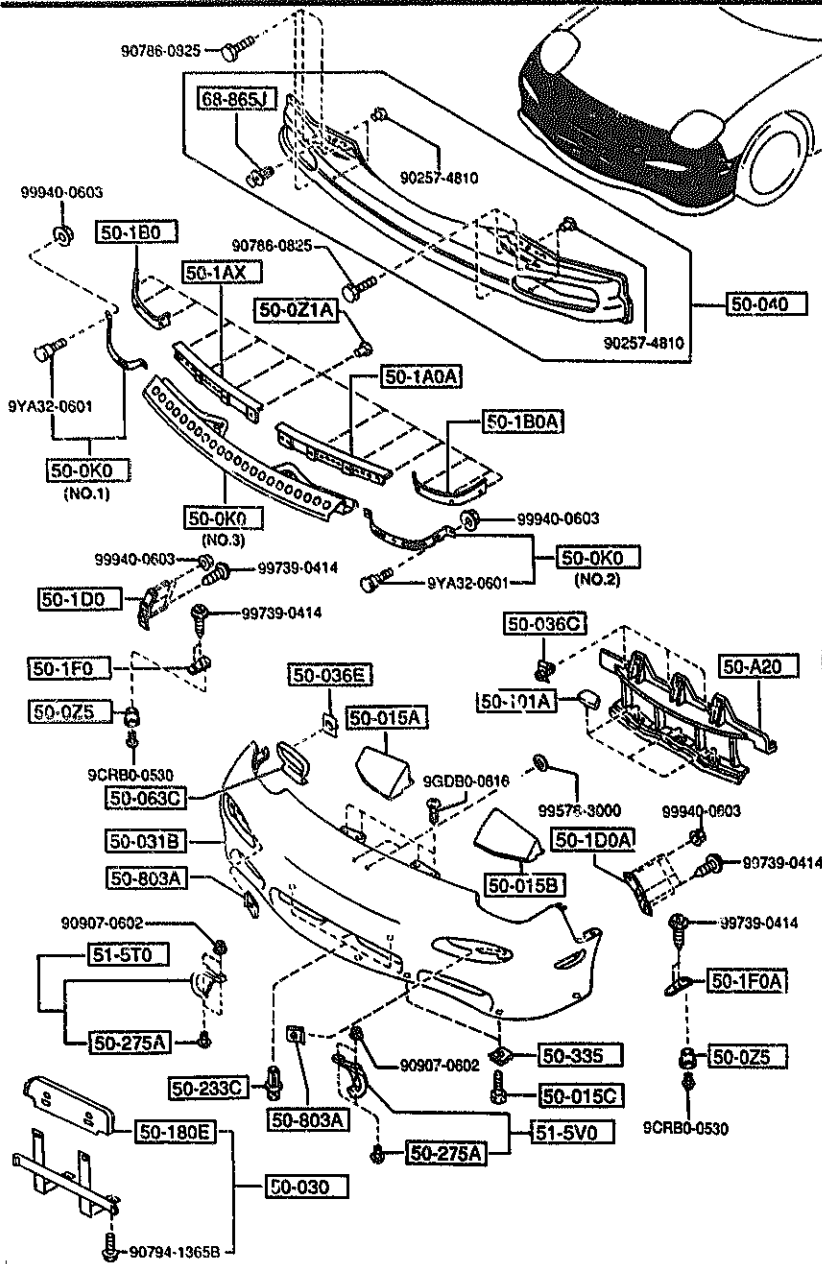

AUFA05

PART NO.	QTY	MODEL/RESTRICTION	MODEL/RESTRICTION	MODEL/RESTRICTION	FROM-TO
CONT'D G158-50-803	2				
51-5T0		COVER(R), BUMPER			
FD01-51-5T0	1	(W/O SUN-RF) (STEEL SUN-RF)			
51-5V0		COVER(L), BUMPER			
FD01-51-5V0	1	(W/O SUN-RF) (STEEL SUN-RF)			
68-865J		FASTENER, TRK. S. TRIM			
B103-68-865	1				

CAT. AUFA05-03

1995-03

2-G10

5010 REAR BUMPER

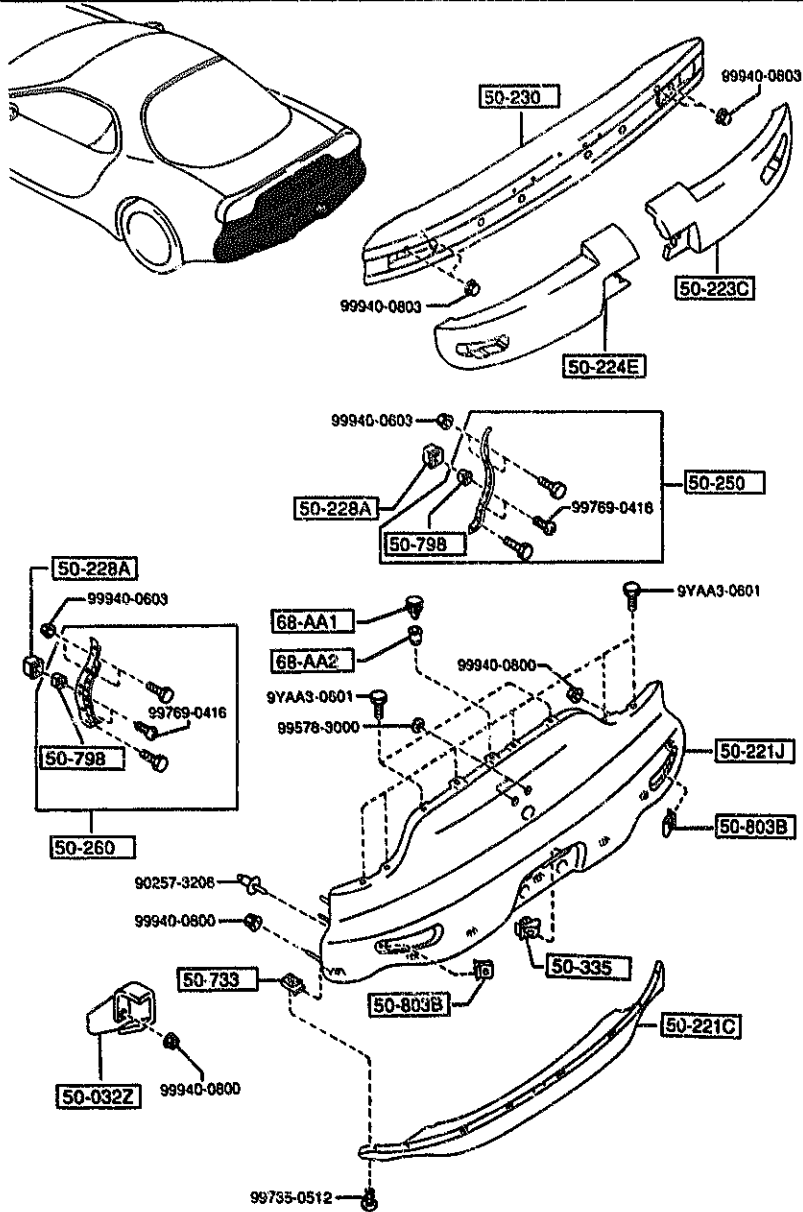

5010 -1 REAR BUMPER

PART NO.	QTY	MODEL/RESTRICTION	MODEL/RESTRICTION	MODEL/RESTRICTION	FROM-TO
50-032Z		PROTECTOR(L)			
FD01-50-1J1	1				
50-221C		BUMPER, REAR LOWER			
FD01-50-231A	1	PAINT TO MATCH			
50-221J		BUMPER, REAR			
FD01-50-221B	1	PAINT TO MATCH			
50-223C		FOAM(R), ENGY. ABS. -RR BUMP			
FD07-50-31X	1				
50-224E		FOAM(L), ENGY. ABS. -RR BUMP			
FD07-50-31Y	1				
50-228A		GROMMET			
FD01-50-AF5	4				
50-230		REINFORCEMENT, BUMPER			
FD01-50-260A	1				
50-250		BRACKET(R), RR. BUMPER			
FD01-50-3A0	1				
50-260		BRACKET(L), RR. BUMPER			
FD01-50-3B0	1				
50-335		NUT, CLIP			
FB01-50-133C	2				
50-733		NUT, SPRING-AIR DAM S KIRT			
FB01-50-733	7				
50-798		SCREW, GROMMET			
FD01-50-799	4				
50-803B		NUT, SPRING			
FD01-50-803	2				

AUFA05

CAT. AUFA05-03

1995-03

5010 -2 * REAR BUMPER

5010 REAR BUMPER

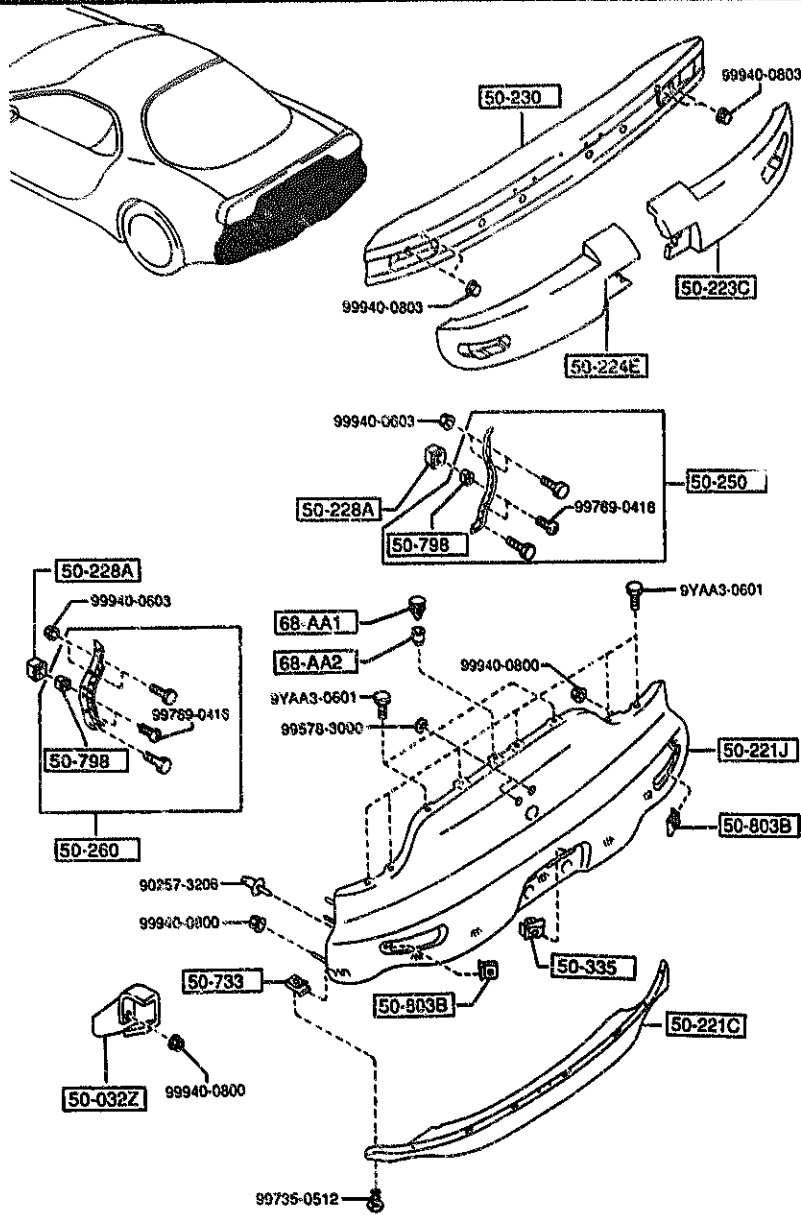

PART NO.	QTY	MODEL/RESTRICTION	MODEL/RESTRICTION	MODEL/RESTRICTION	FROM TO
68-AA1		FASTENER			
LA10-68-AA1	1				
68-AA2		FASTENER, SEAL-TRIM			
LA10-68-AA2	1				

AUFA05

CAT. AUFA05-03

1995-03

5020 HEAD LAMP CLEANER
(SUN ROOF)

5020 -1 HEAD LAMP CLEANER
(SUN ROOF)

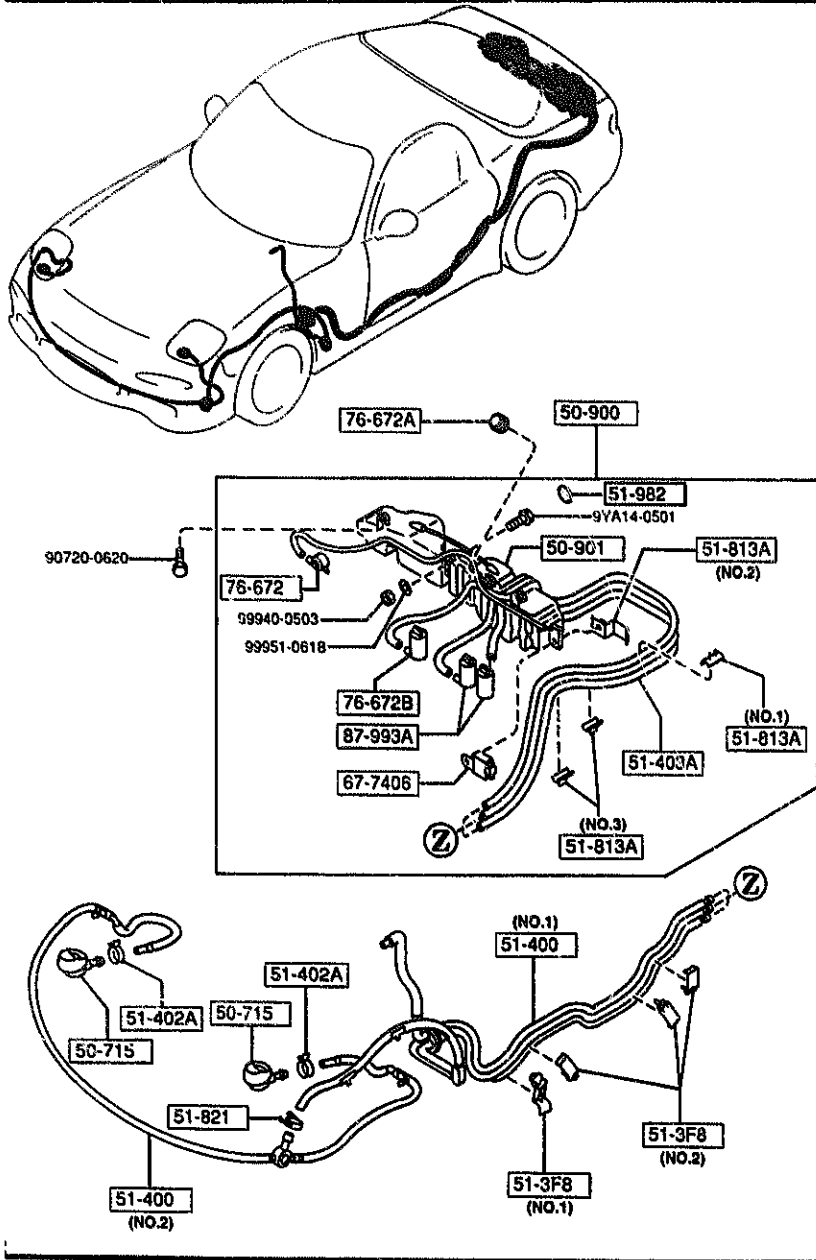

PART NO.	QTY	MODEL/RESTRICTION	MODEL/RESTRICTION	MODEL/RESTRICTION	FROM-TO
50-715		NOZZLE, WASHER			
FD13-51-820	2				
50-900		TANK & MOTOR, WASHER			
FD07-51-810F	1				
50-901		TANK, WASHER			
FD07-51-812B	1				
51-3F8		HOLDER			
FD07-51-3F8	1	(ILLUST. NO.1)			
FD09-51-3F8A	3	(ILLUST. NO.2)			
51-400		PIPE, H/L CLEANER			
FD07-51-40XB	1	(ILLUST. NO.1)			
FD07-51-400B	1	(ILLUST. NO.2)			
51-402A		CLIP			
3972-51-402	2				
51-403A		PIPE			
FD07-51-403A	1				
51-813A		HOLDER, MOTOR-H.L. CLEANER			
FD07-51-813A	1	(ILLUST. NO.1)			
FD08-51-813A	1	(ILLUST. NO.2)			
FD09-51-813	2	(ILLUST. NO.3)			
51-821		CLIP			
BD63-51-821	1				
51-982		PROTECTOR			
FD07-51-982	1				
67-7406		RELAY & BRACKET, NORMAL OP 30A			
H280-67-740	1				
76-672		PUMP, WASHER			
8532-76-672	1				

AUFA05

CAT. AUFA05-03

1995-03

5020 HEAD LAMP CLEANER
(SUN ROOF)

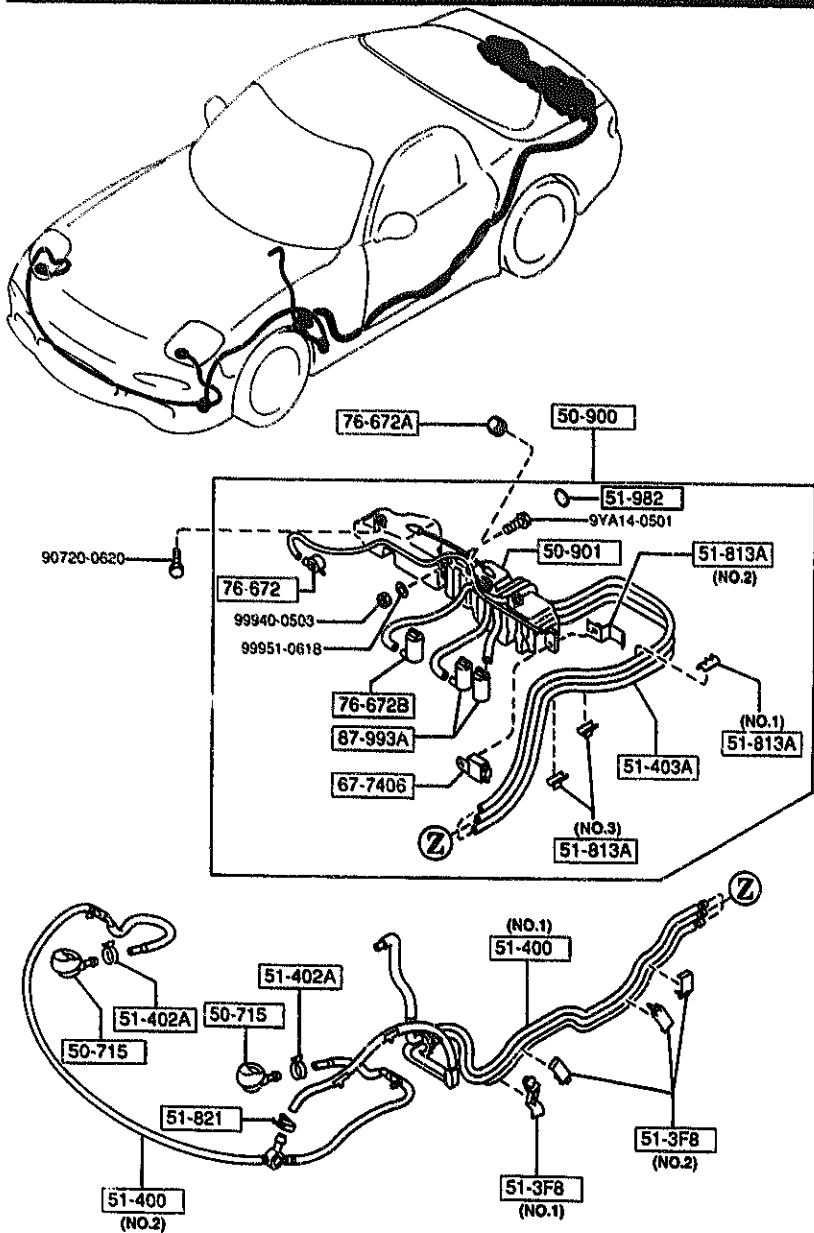

AUFA05

5020 -2 * HEAD LAMP CLEANER
(SUN ROOF)

PART NO.	QTY	MODEL/RESTRICTION	MODEL/RESTRICTION	MODEL/RESTRICTION	FROM-TO
76-672A		CAP, TANK			
FD02-67-483	1				
76-672B		PUMP, WASHER			
FD01-67-482	1				
87-993A		PUMP KIT			
FD13-51-811	2				

CAT. AUFA05-03

1995-03

2-K10

5030 WINDOW MOULDINGS

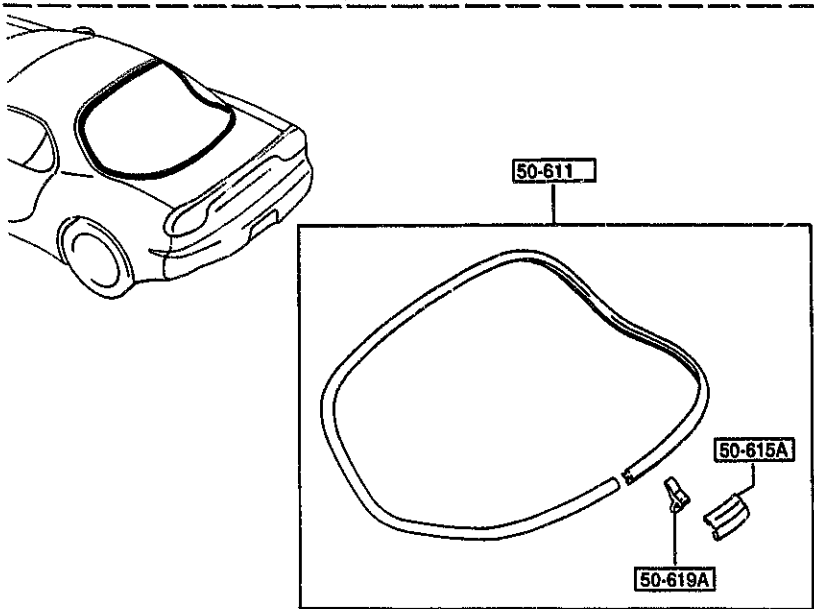
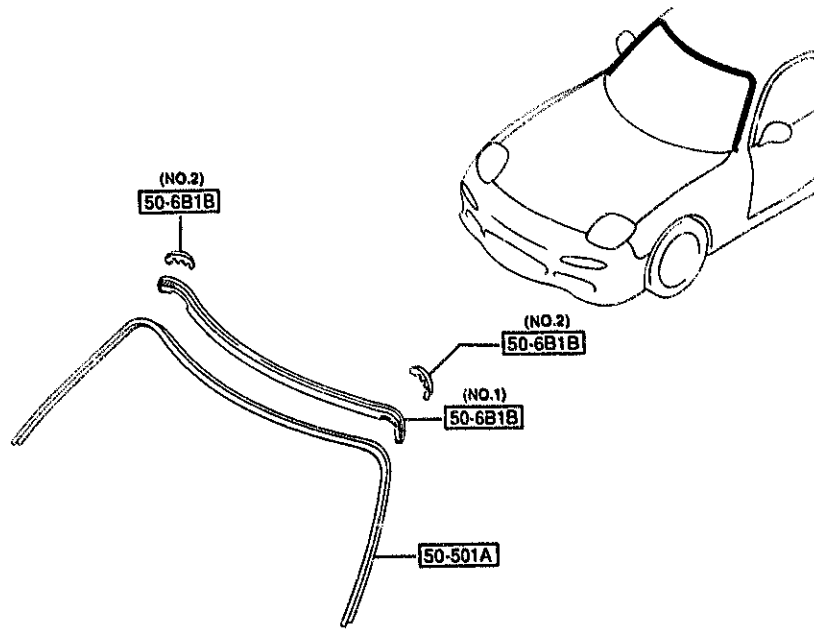

PART NO.	QTY	MODEL/RESTRICTION	MODEL/RESTRICTION	MODEL/RESTRICTION	FROM-TO
50-501A FD01-50-6AXB	1	MOULD(UP),FRT.WINDOW			
50-6B1B NA01-50-6B1	1	PROTR,MOULD-FRT WIND OW (ILLUST. NO.1)			
50-6B1B NA01-50-6B2	2	(ILLUST. NO.2)			
50-611 FD01-50-600B	1	MOULD,RR.WINDOW			
50-615A FD01-50-615	1	JOINT,BACK WINDOW MO ULD			
50-619A FD01-50-619A	1	CLIP,RR.WINDOW MOULD			

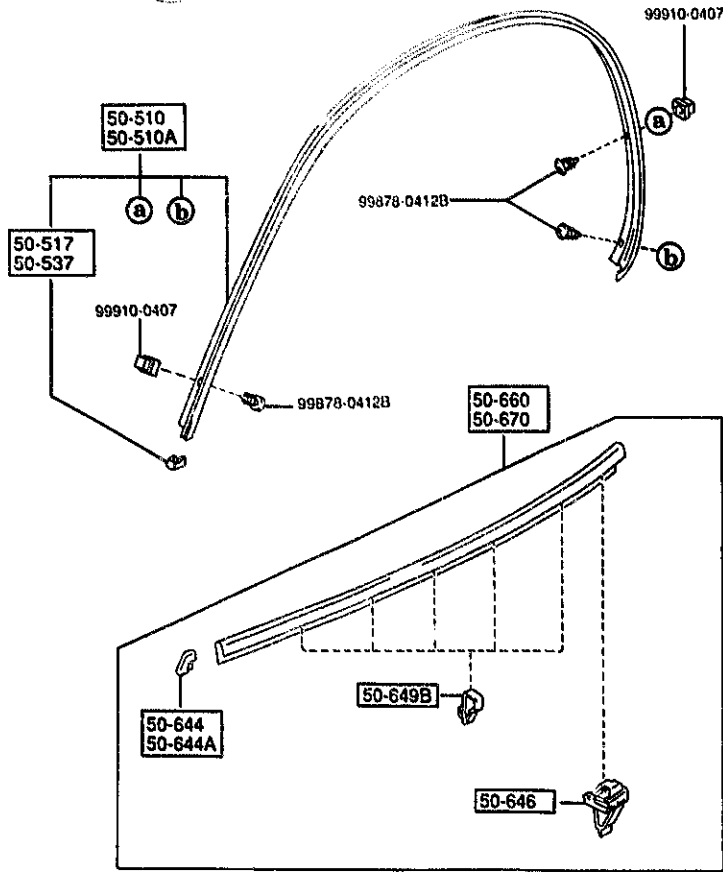
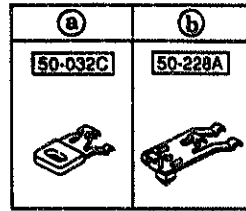
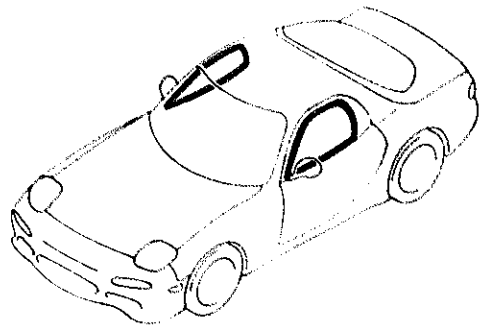

PART NO.	QTY	MODEL/RESTRICTION	MODEL/RESTRICTION	MODEL/RESTRICTION	FROM-TO
50-032C		GROMMET			
*FD01-50-538A	2				
50-228A		GROMMET			
*FD01-50-539A	2				
50-510		MOULD(R), DRIP			
FD01-50-510E	1				
50-510A		MOULD(L), DRIP			
FD01-50-530E	1				
50-517		PROTECTOR(R), DRIP ML DG			
FD01-50-516A	1				
50-537		PROTECTOR(L), DRIP ML DG			
FD01-50-536A	1				
50-644		PROTECTOR'A'(R), BELT LINE			
FD01-50-644A	1				
50-644A		PROTECTOR'A'(L), BELT LINE			
FD01-50-654A	2				
50-646		CLIP, BELTLINE MOULD			
FD01-50-646B	2				
50-649B		CLIP'A', BELTLINE MOULD			
FD01-50-649A	10				
50-660		MOULD(R), BELTLINE			
FD01-50-640D	1				
50-670		MOULD(L), BELTLINE			
FD01-50-650D	1				

5100 HEAD LAMPS

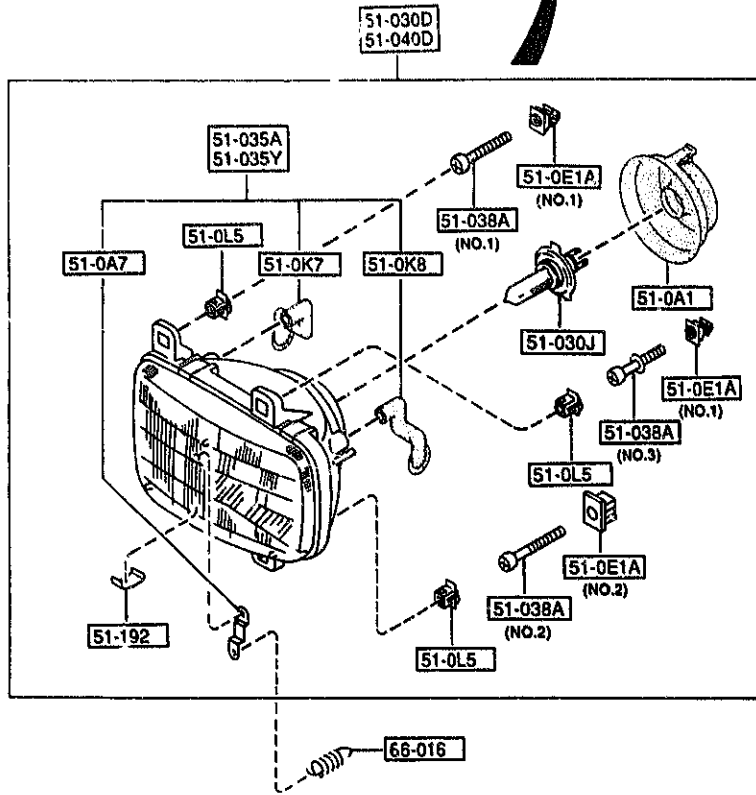
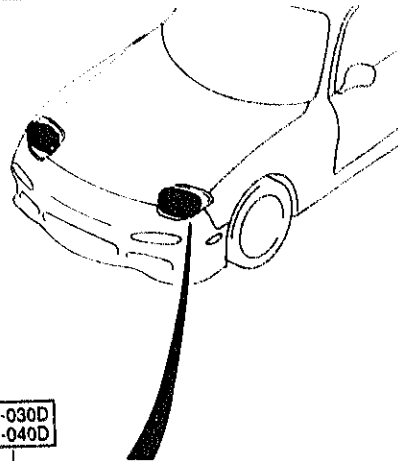

PART NO.	QTY	MODEL/RESTRICTION	MODEL/RESTRICTION	MODEL/RESTRICTION	FROM TO
51-0A1		COVER, SOCKET-HEAD LAMP			
FD01-51-0A1	2				
51-0A7		BRACKET, HEAD LAMP			
FD01-51-0A7	2				
51-0E1A		FASTENER, LAMP			
BR70-51-0E1	4 (ILLUST. NO.1)				
FD01-51-0E1	2 (ILLUST. NO.2)				
51-0K7		TUBE, HEAD LAMP			
FD01-51-0K7	2				
51-0K8		TUBE, HEAD LAMP			
FD01-51-0K8	2				
51-0L5		BEARING, HEAD LAMP			
FD01-51-0L5	6				
51-030D		LAMP(R), HEAD			
FD01-51-030D	1				
51-030J		BULB			
99703-8605	2	12V 60/55W			
51-035A		UNIT(R), HEAD LAMP			
FD01-51-0K0D	1				
51-035Y		UNIT(L), HEAD LAMP			
FD01-51-0L0D	1				
51-038A		SCREW, ADJUST			
FD01-51-037	2 (ILLUST. NO.1)				
FD02-51-037	2 (ILLUST. NO.2)				
FD01-51-047	2 (ILLUST. NO.3)				
51-040D		LAMP(L), HEAD			
FR01-51-040D	1				

5100 HEAD LAMPS

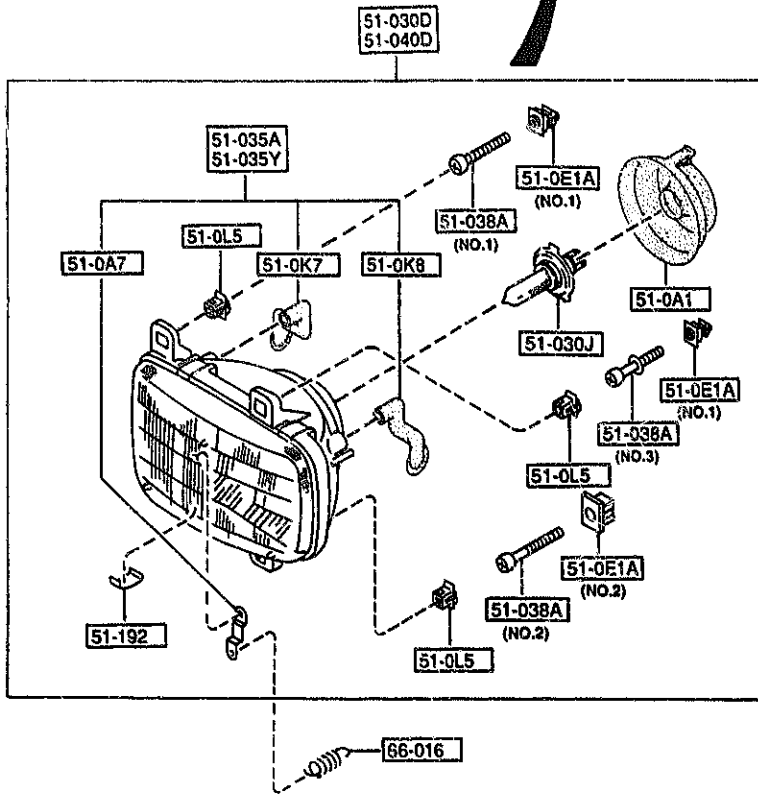
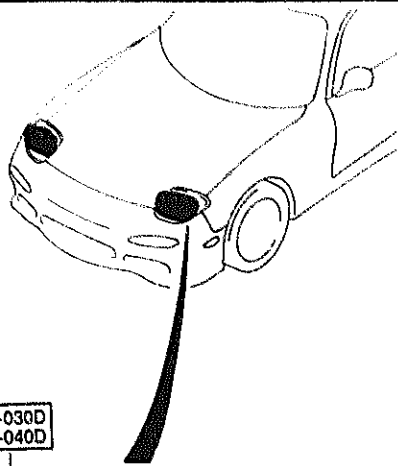

PART NO.	QTY	MODEL/RESTRICTION	MODEL/RESTRICTION	MODEL/RESTRICTION	FROM-TO
51-192		CLTP			
B455-51-0A6	8				
66-016		SPRING, ADJUST			
FC42-51-036	2				

5103 HEAD LAMP RETRACTORS

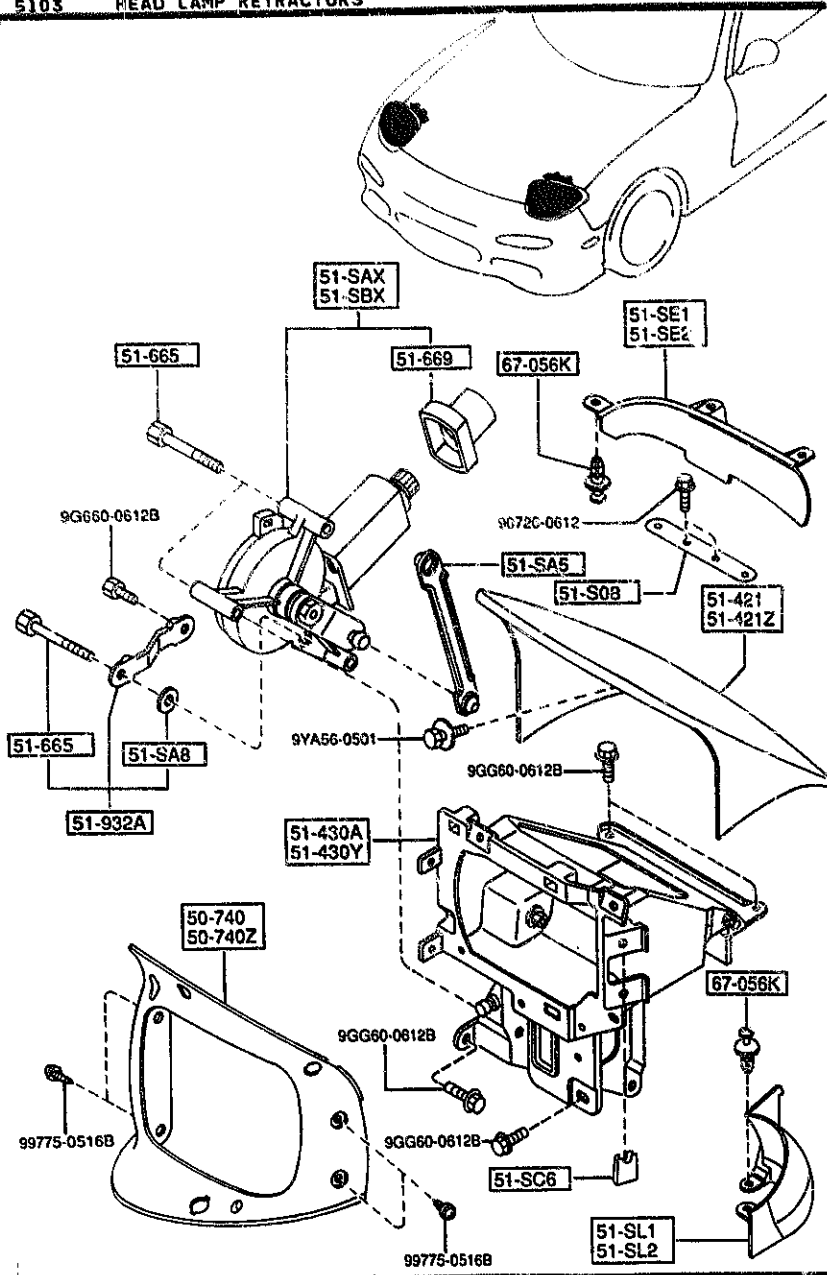

PART NO.	QTY	MODEL/RESTRICTION	MODEL/RESTRICTION	MODEL/RESTRICTION	FROM-TO
50-740		BEZEL(R),LAMP			
FD01-50-741C	1				
50-740Z		BEZEL(L),LAMP			
FD01-50-751C	1				
51-SAX		MOTOR(R),RETRACTABLE HEAD			
FD01-51-SAXB	1				
51-SAS		ROD,RETRACTABLE			
FD01-51-SAS5	2				
51-SAB		WASHER			
NA01-51-SAB	2				
51-SBX		MOTOR(L),RETRACTABLE HEAD			
FD01-51-SBxB	1				
51-SC6		NUT,STOPPER-LAMP HINGE			
FD01-69-276A	6				
51-SE1		PROTECTOR(R),RETRA H/L			
FD01-51-SE1A	1				
51-SE2		PROTECTOR(L),RETRA. H/L			
FD01-51-SE2A	1				
51-SL1		PROTECTOR(R),FENDER			
FD01-51-SL1A	1				
51-SL2		PROTECTOR(L),FENDER			
FD01-51-SL2A	1				
51-S08		PLATE,RETRACTABLE			
FD01-51-S08A	2				
51-421		LID(R),LAMP			
FDY2-51-SH1	1				
51-421Z		LID(L),LAMP			
FDY2-51-SH2	1				

AUFA05

-183-

CAT. AUFA05-03

1995-03

2-D11

5103 -2 * HEAD LAMP RETRACTORS

5103 HEAD LAMP RETRACTORS

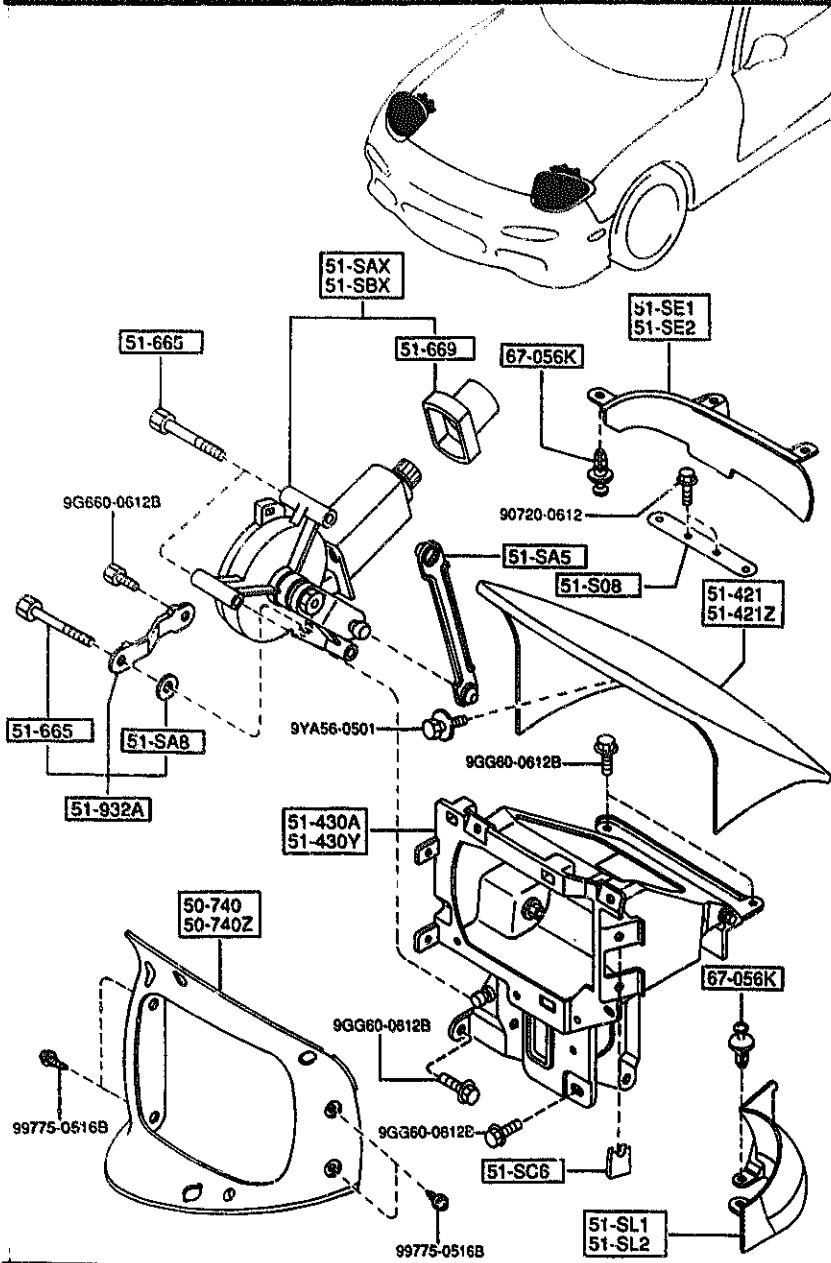

PART NO.	QTY	MODEL/RESTRICTION	MODEL/RESTRICTION	MODEL/RESTRICTION	FROM-TO
51-430A		HINGE(R), LID-LAMP			
FD01-51-SC0D	1				
51-430Y		HINGE(L), LID-LAMP			
FD01-51-SD0D	1				
51-665		BOLT, MOTOR-RETRACT H /LAMP			
FB01-51-665	6				
51-669		BOOT, MOTOR-RETRACT H /L			
NA01-51-669	2				
51-932A		BRACKET, MOTOR			
FD01-51-S1V	2				
67-056K		RIVET			
UB39-50-795	10				

AUFA05

-183-

CAT. AUFA05-03

1995-03

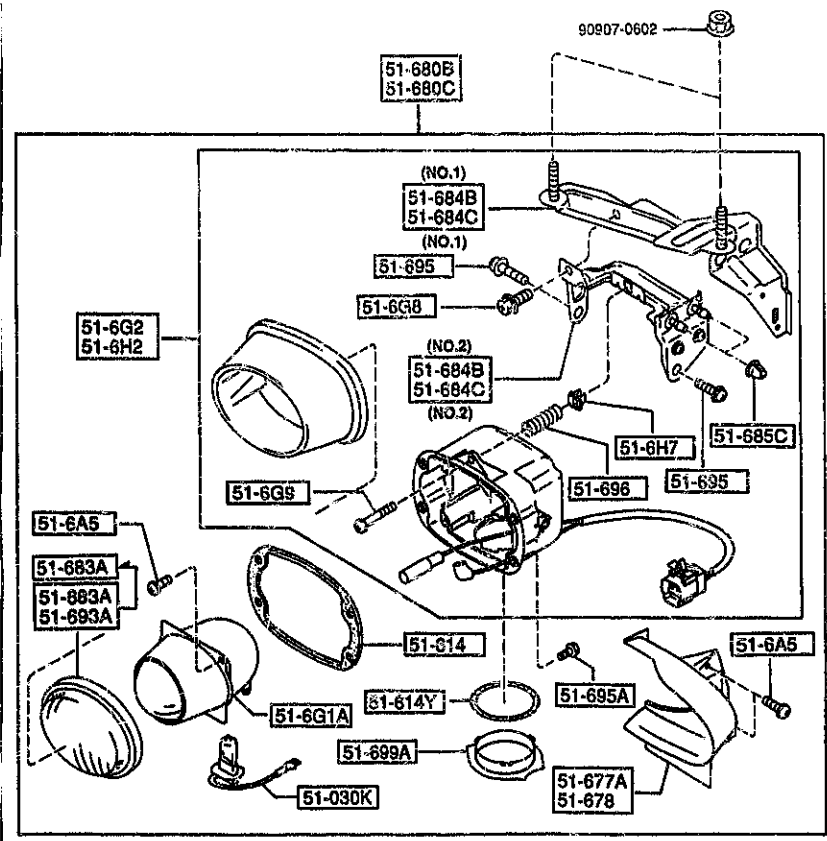
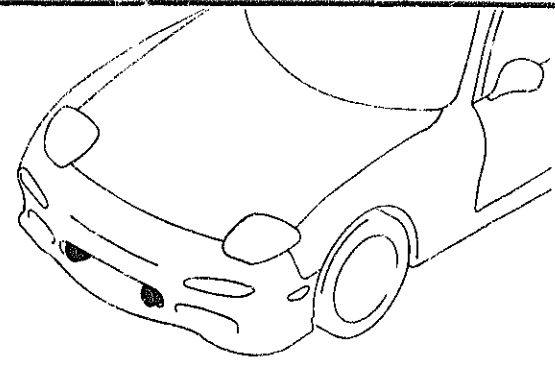
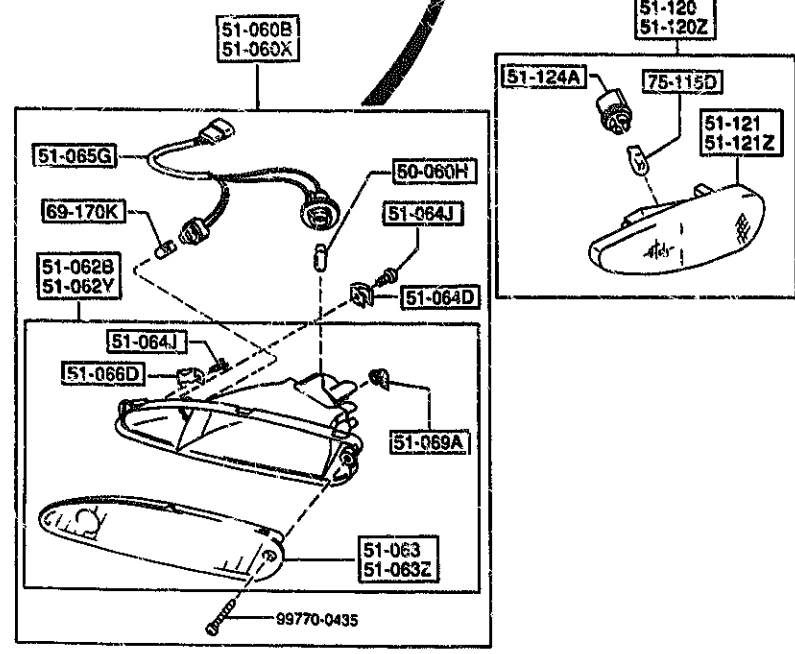
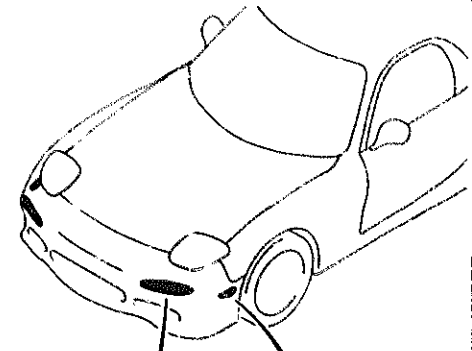

2-511

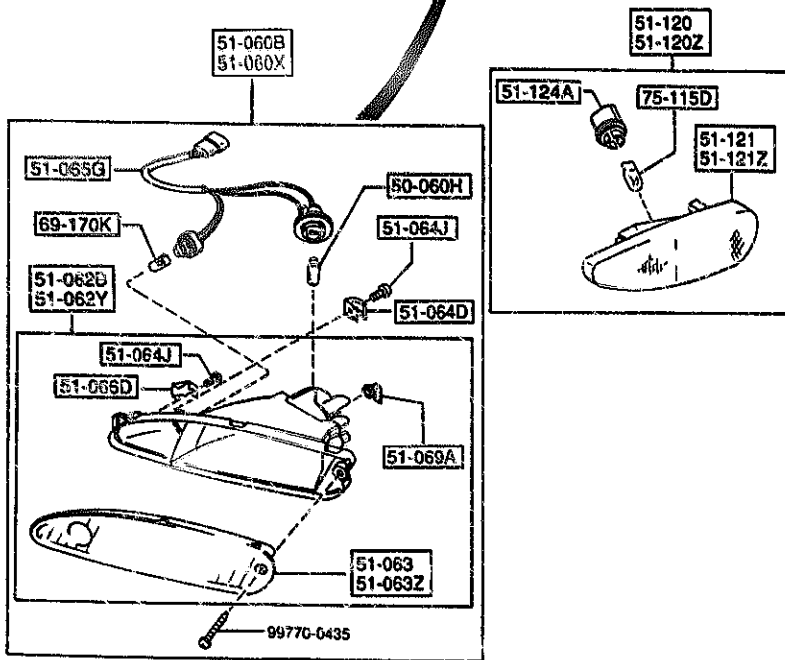
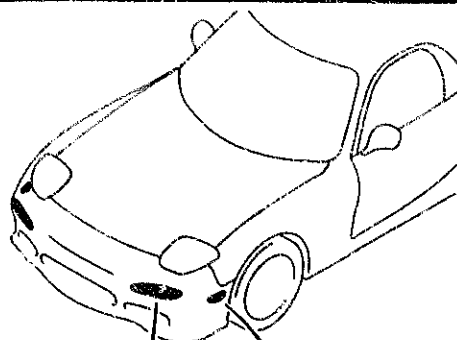

PART NO.	QTY	MODEL/RESTRICTION	MODEL/RESTRICTION	MODEL/RESTRICTION	FROM-TO
51-030K		BULB			
99703-4350	2	12V/35W (GLASS SUN-RF)			
51-060B		LAMP(R), FRT. COMB.			
FD01-51-060D	1				
51-060H		BULB			
90701-7270	2	12V/27W			
51-060X		LAMP(L), FRT. COMB.			
FD01-51-070D	1				
51-062B		LENS & BODY(R), F. CO MB.			
FD01-51-06XB	1				
51-062Y		LENS & BODY(L), F. CO MB.			
FD01-51-07XB	1				
51-063		LENS(R), FRT COMB.			
FD01-51-061	1				
51-063Z		LENS(L), FRT COMB.			
FD01-51-071	1				
51-064D		SPRING, FRT. COMB.			
FD01-51-057	2				
51-064J		SCREW, TAPPING			
FD01-51-1E6	4				
51-065G		SOCKET, F. COMB. LAMP			
FD01-51-064A	2				
51-066D		BRACKET, FRONT COMB. LAMP			
FD01-51-056	2				
51-069A		TUBE, HEAD LAMP			
NA01-51-069	2				

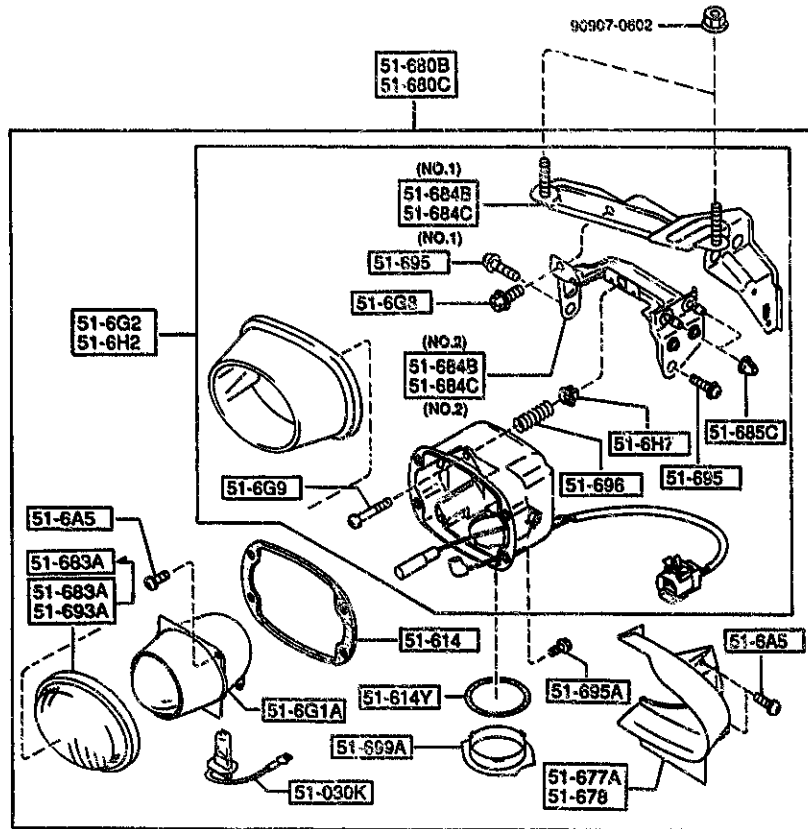
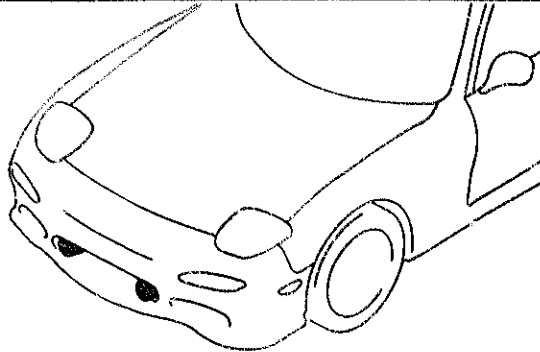

PART NO.	QTY	MODEL/RESTRICTION	MODEL/RESTRICTION	MODEL/RESTRICTION	FROM-TO
51-120		LAMP(R),SIDE TURN			
FD01-51-5E08	1				
51-120Z		LAMP(L),SIDE TURN			
FD01-51-5F08	1				
51-121		LENS & BODY(R)			
FD01-51-5E1B	1				
51-121Z		LENS & BODY(L)			
FD01-51-5F1B	1				
51-124A		SOCKET,SIDE TURN			
H380-51-5E2	2				
51-6A5		SCREW,F. FOG LAMP			
FD01-51-6A5	8	(GLASS SUN-RF)			
51-691A		UNIT,FOG LAMP			
FD01-51-691A	2	(GLASS SUN-RF)			
51-692		HOUSING(R),FOG LAMP			
FD01-51-69YB	1	(GLASS SUN-RF)			
51-698		BOLT,SPECIAL			
FD01-51-698	2	(GLASS SUN-RF)			
51-699		SCREW,ADJUST			
FD01-51-699	2	(GLASS SUN-RF)			
51-6H2		HOUSING(L),FOG LAMP			
FD01-51-69YB	1	(GLASS SUN-RF)			
51-6H7		SCREW,GROMMET			
FD01-51-6H7	2	(GLASS SUN-RF)			
51-614		GASKET			
FD01-51-682	2	(GLASS SUN-RF)			
51-614V		GASKET(L)			
FD01-51-692	2	(GLASS SUN-RF)			

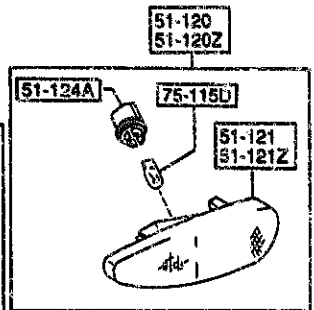
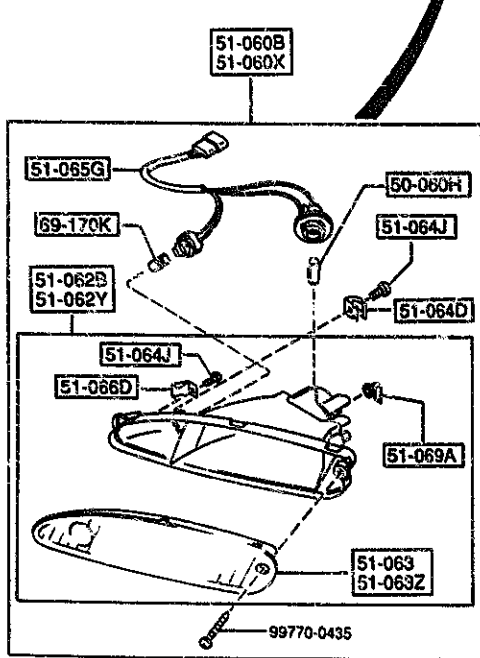
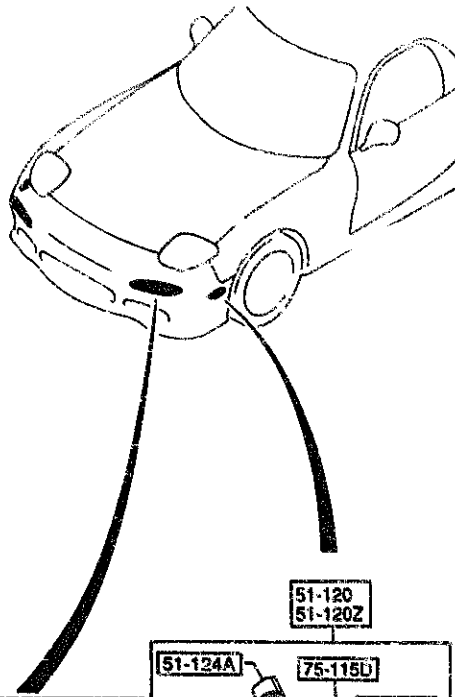

PART NO.	QTY	MODEL/RESTRICTION	MODEL/RESTRICTION	MODEL/RESTRICTION	FROM-TO
51-677A		COVER(R), FOG LAMP			
FD01-51-677	1	(GLASS SUN-RF)			
51-678		COVER(L), FOG LAMP			
FD01-51-678	1	(GLASS SUN-RF)			
51-680B		LAMP(R), F. FOG			
FD01-51-680C	1	(GLASS SUN-RF)			
51-680C		LAMP(L), F. FOG			
FD01-51-690C	1	(GLASS SUN-RF)			
51-683A		LENS, FRONT FOG LAMP			
FD01-51-683	1	(FOR RIGHT)			-4106
		(GLASS SUN-RF)			
FD01-51-683	2	(GLASS SUN-RF)			4106-
51-684B		BRACKET(R), F. FOG LAMP			
FD01-51-684A	1	(ILLUST. NO. 1)			
		(GLASS SUN-RF)			
FD02-51-684	1	(ILLUST. NO. 2)			
		(GLASS SUN-RF)			
51-684C		BRACKET(L), LAMP-F. FOG			
FD01-51-694A	1	(ILLUST. NO. 1)			
		(GLASS SUN-RF)			
FD02-51-694	1	(ILLUST. NO. 2)			
		(GLASS SUN-RF)			
51-685C		CLIP			
FD01-51-674	4	(GLASS SUN-RF)			
51-693A		LENS(L), FOG LAMP			
FD01-51-693	1	(GLASS SUN-RF)			-4106
51-695		SCREW, FRONT FOG LAMP			
FD01-51-695	4	(GLASS SUN-RF)			
51-695A		SCREW, LAMP			
FD01-51-671	8	(GLASS SUN-RF)			
51-696		SPRING, FRONT FOG LAMP			
4106 FD333*-301753					

5105 -4 * FRONT COMBINATION LAMPS

5105 FRONT COMBINATION LAMPS

(2/2)

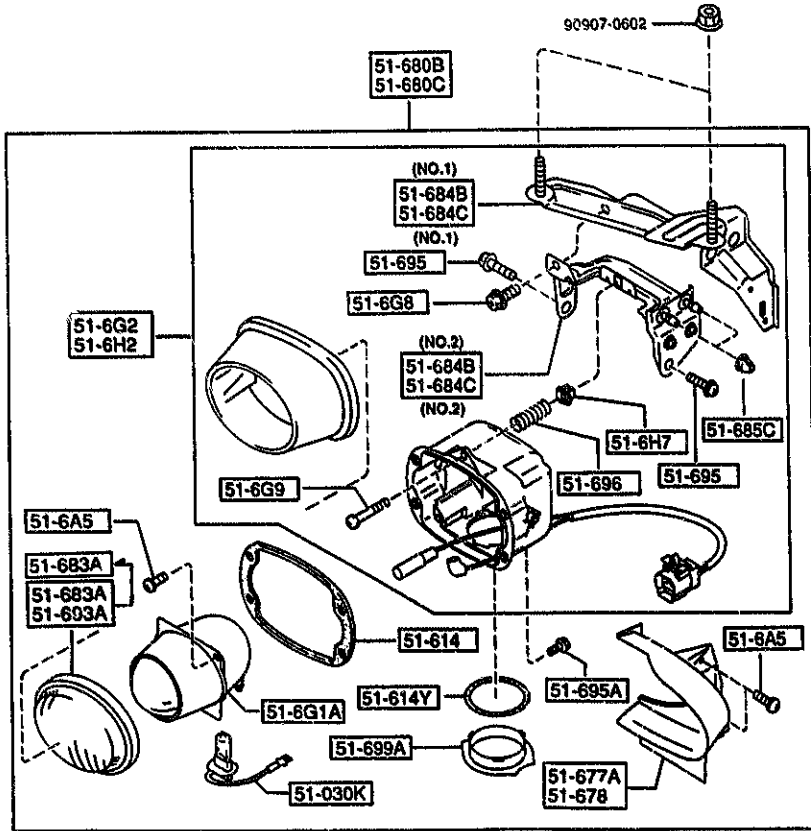
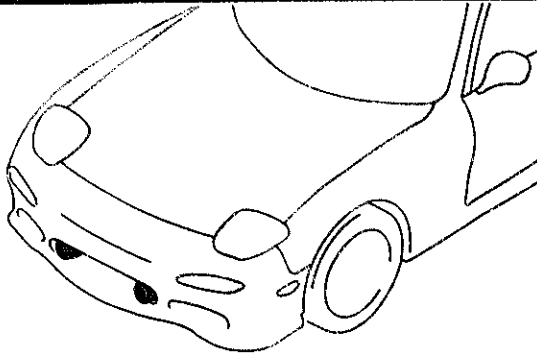

PART NO.	QTY	MODEL/RESTRICTION	MODEL/RESTRICTION	MODEL/RESTRICTION	FROM-TO
CONT'D FD01-51-696	2	(GLASS SUN-RF)			
51-699A		COVER, F. FOG LAMP			
FD01-51-676	2	(GLASS SUN-RF)			
69-171K		BULB, INTERIOR MIRROR			
99701-6050	2	12V 5W			
75-115D		BULB			
99701-6049	2	12V 3CP			

5110 REAR COMBINATION LAMPS

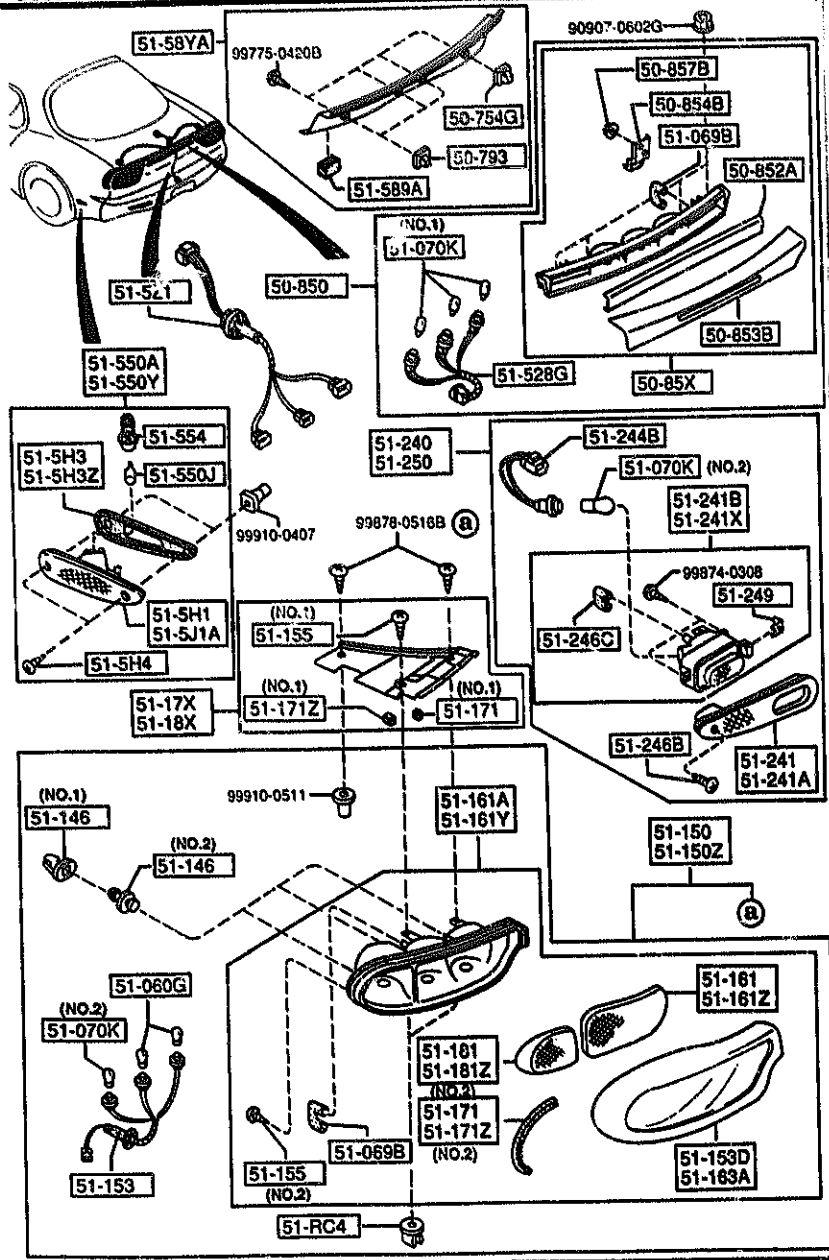

PART NO.	QTY	MODEL/RESTRICTION	MODEL/RESTRICTION	MODEL/RESTRICTION	FROM-TO
50-754G		GROMMET, SCREW			
FD03-50-792	1				
50-793		GROMMET, SCREW			
FD02-50-792	3				
50-85X		LENS & BODY, REAR FINISHER			
FD01-51-59XA	1				
50-850		FINISHER, REAR			
FD01-50-850C	1				
50-852A		LENS, REAR FINISHER			
FD01-51-577	1				
50-853B		LENS, REAR FINISHER			
FD01-51-591	1				
50-854B		BRACKET, REAR FINISHER			
FD01-51-585	4				
50-857B		NUT, SPEED-REAR FINISHER			
FD01-51-594	8				
51-RC4		GROMMET, SIDE GARNISH			
FD01-51-RC4	4				
51-060G		BULB			
99701-4278	4	12V 27W/8W			
51-069B		TUBE, LAMP-FRONT COMB			
B481-51-069	3				
51-070K		BULB			
99700-7180	3	A12V 18.4W (ILLUST. NO.1)			
99701-3270	4	12V 27W (ILLUST. NO.2)			
51-146		GROMMET, SCREW-R.COMB			
EA02-51-146A	6	(ILLUST. NO.1)			

5110 REAR COMBINATION LAMPS

5110 -2 REAR COMBINATION LAMPS

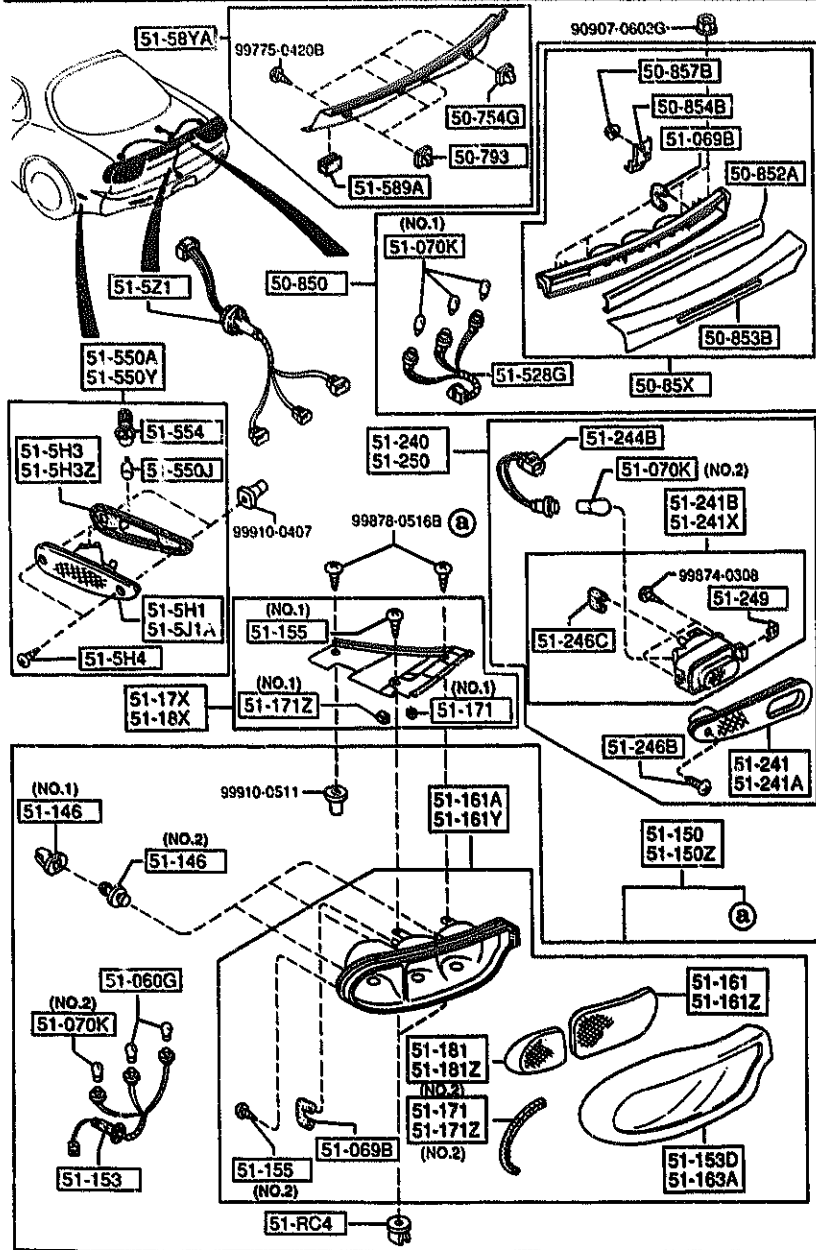

PART NO.	QTY	MODEL/RESTRICTION	MODEL/RESTRICTION	MODEL/RESTRICTION	FROM-TO
CONT'D EA04-51-146A	6	(ILLUST. NO.2)			
51-150		LAMP SET(R),RR.COMB.			
8BFH-51-150	1				
51-150Z		LAMP SET(L),RR.COMB.			
8BFH-51-160	1				
51-153		SOCKET,RR.COMB.			
FD01-51-155B	2				
51-153D		LENS NO.3(R),RR.COMB. LAMP			
FD01-51-153B	1				
51-155		SCREW,RR.COMB.			
FD01-51-143	2	(ILLUST. NO.1)			
FD01-51-144	12	(ILLUST. NO.2)			
51-161		LENS(R),RR.COMB.			
FD01-51-151	1				
51-161A		LENS & BODY(R),RR.COMB.			
FD01-51-170B	1				
51-161Y		LENS & BODY(L),RR.COMB.			
FD01-51-180B	1				
51-161Z		LENS(L),RR.COMB.			
FD01-51-161	1				
51-163A		LENS NO.3(L),RR.COMB. LAMP			
FD01-51-163B	1				
51-17X		COVER(R),RR.COMB.			
FD01-51-17XE	1				
51-171		PROTECTOR(R),RR.COMB.			
FD02-51-159	2	(ILLUST. NO.1)			
FD01-51-173	1	(ILLUST. NO.2)			

AUFA05

CAT. AUFA05-03

1995-03

5110 REAR COMBINATION LAMPS

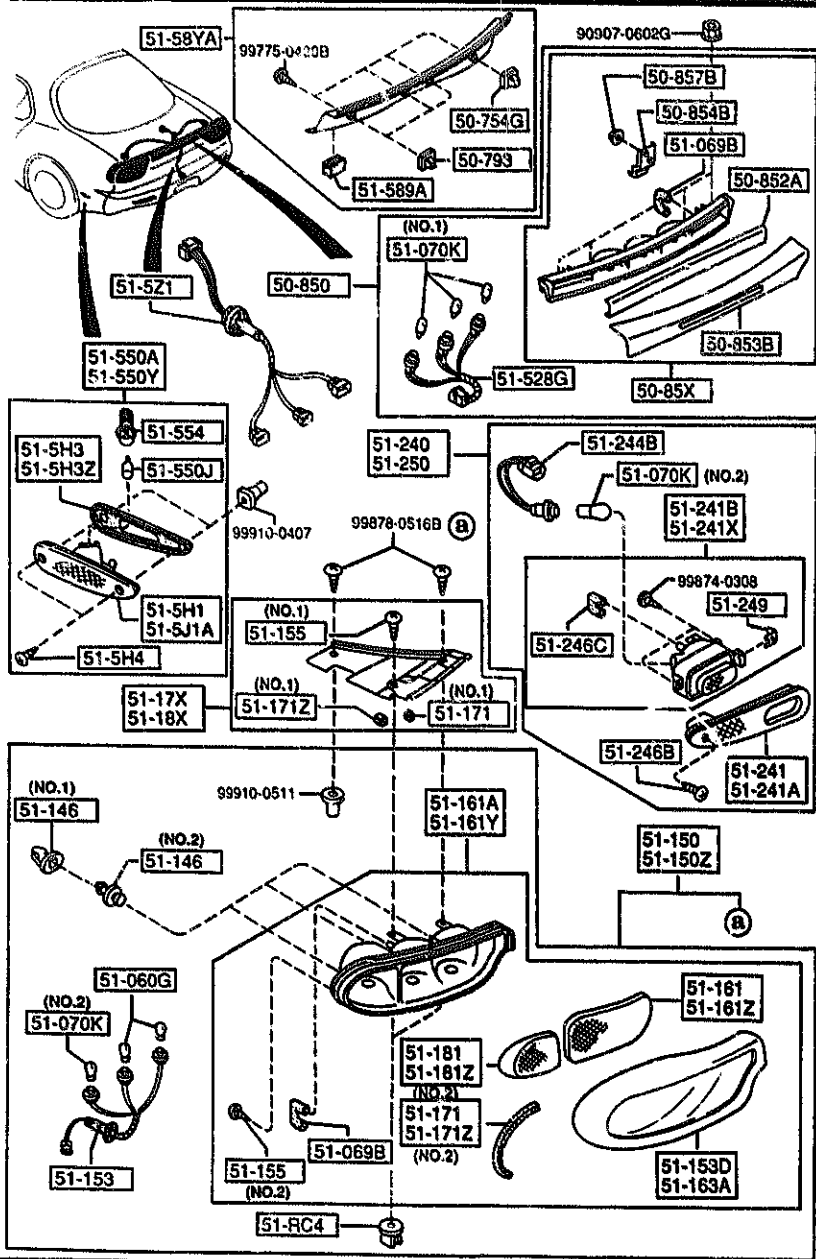

PART NO.	QTY	MODEL/RESTRICTION	MODEL/RESTRICTION	MODEL/RESTRICTIONS	FROM-TO
51-171Z		PROTECTOR(L),RR.COMB			
FD02-51-169	4	(ILLUST. NO.1)			
FD01-51-183	1	(ILLUST. NO.2)			
51-18X		COVER(L),RR.COMB.			
FD01-51-18XE	1				
51-181		LENS NO.2(R),RR.COMB			
FD01-51-152	1				
51-181Z		LENS NO.2(L),RR.COMB			
FD01-51-162	1				
51-240		LAMP(R),BACK UP			
FD01-51-240B	1				
51-241		HOUSING(R),BACK UP LAMP			
FD01-51-241B	1				
51-241A		HOUSING(L),BACK UP LAMP			
FD01-51-251B	1				
51-241B		LENS & BODY(R),BACK UP			
FD01-51-24XA	1				
51-241X		LENS & BODY(L),BACK UP			
FD01-51-25XA	1				
51-249B		SOCKET,BACK UP LAMP			
FD01-51-244	2				
51-246B		SCREW,BACK LAMP			
FD01-51-248	2				
51-246C		TUBE,BACK UP LAMP			
FD01-51-246	2				
51-249		SPRING,BACK UP LAMP			
FD01-51-249	2				

AUFA05

CAT. AUFA05-03

1995-03

2-M11

5110 REAR COMBINATION LAMPS

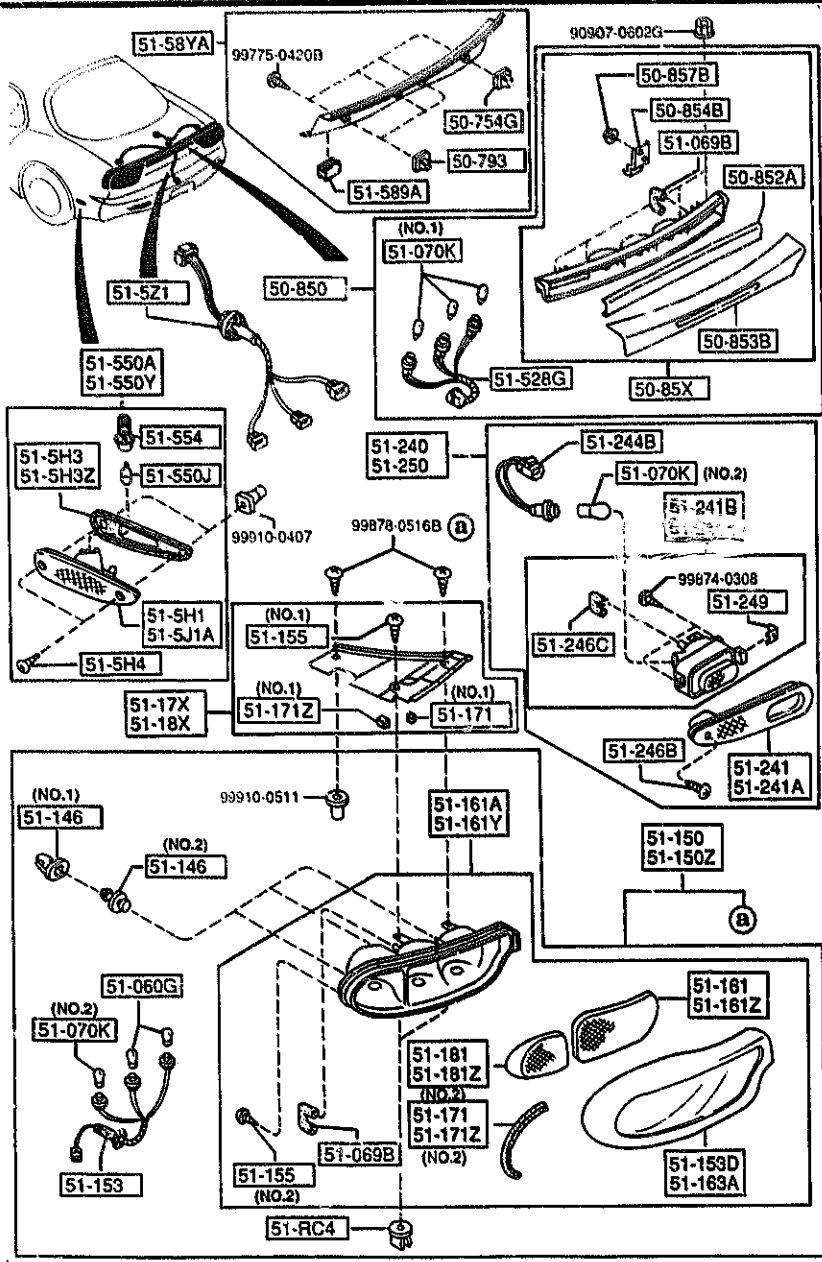

PART NO.	QTY	MODEL/RESTRICTION	MODEL/RESTRICTION	MODEL/RESTRICTION	FROM-TO
51-250	1	LAMP(L), BACK UP			
FD01-51-250B					
51-5H1	1	LENS & BODY(R), RR SIDE TURN			
FD01-51-5H1C					
51-5H3	1	GASKET(R), REAR SIDE			
FD01-51-5H3					
51-5H3Z	1	GASKET(L), REAR SIDE			
FD01-51-5J3					
51-5H4	4	SCREW, REAR SIDE			
FD01-51-5H4					
51-5J1A	1	LENS & BODY(L), RR SIDE TURN			
FD01-51-5J1C					
51-5Z1	1	CORD, LAMP			
FD01-51-5Z1B					
51-528G	1	SOCKET			
FD01-51-584A					
51-550A	1	LAMP(R), SIDE TURN-RR			
FD01-51-5H0D					
51-550A	2	BULB			
99701-6040		12V 3.8W			
51-550Y	1	LAMP(L), SIDE TURN-RR			
FD01-51-5J0B					
51-554	2	SOCKET, RR SIDE TURN LAMP			
FD01-51-5H2					
51-58YA	1	COVER, RR FINISHER			
FD01-51-58YC					
51-589A		PROTECTOR, COVER			

AUFA05

CAT. AUFA05-03

1995-03

5110 REAR COMBINATION LAMPS

5110 -5 M REAR COMBINATION LAMPS

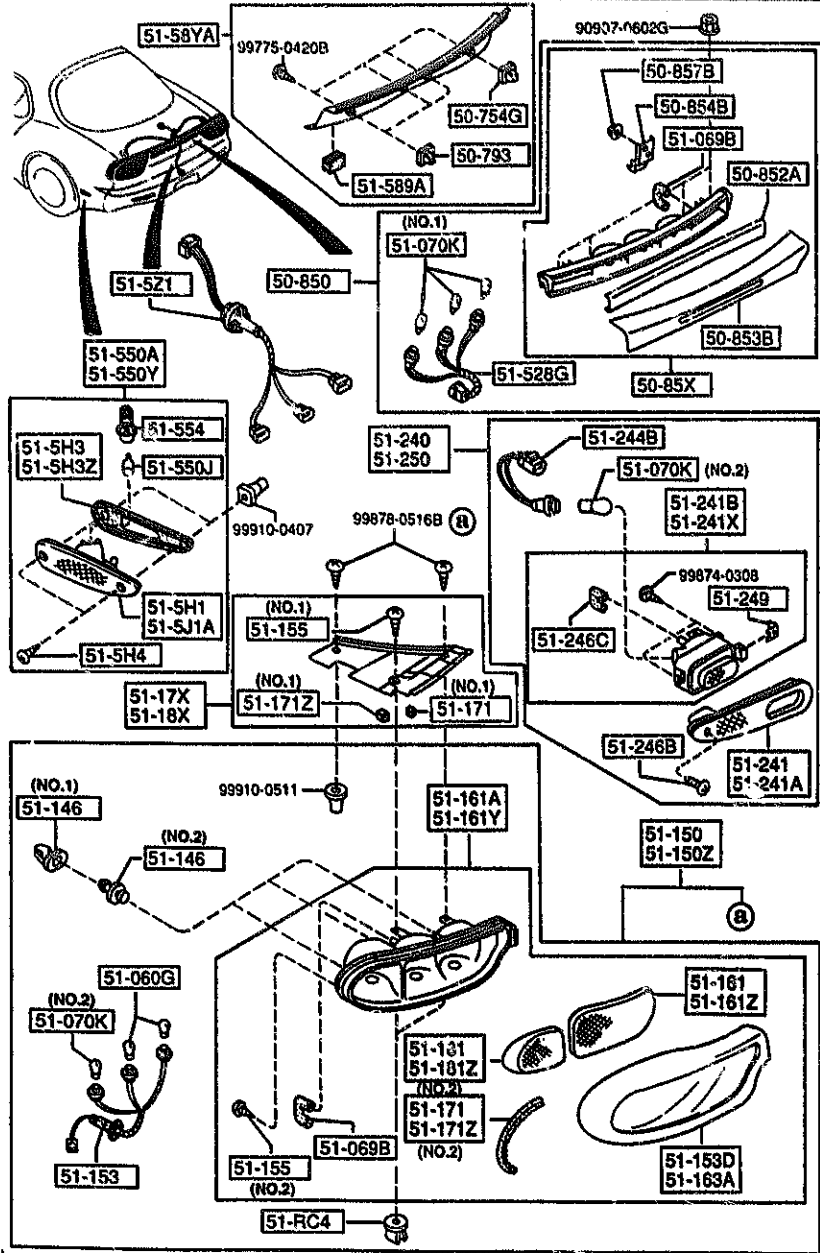

PART NO.	QTY	MODEL/RESTRICTION	MODEL/RESTRICTION	MODEL/RESTRICTION	FROM-TO
CONT'D FD01-51-589	4				

AUFA05

CAT. AUFA05-03

1995-03

5120 LICENSE LAMPS

5120 -1 * LICENSE LAMPS

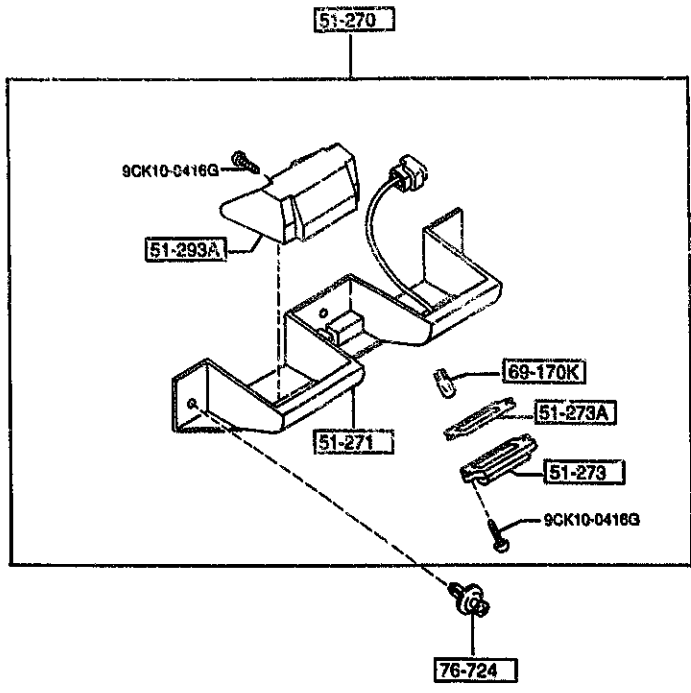
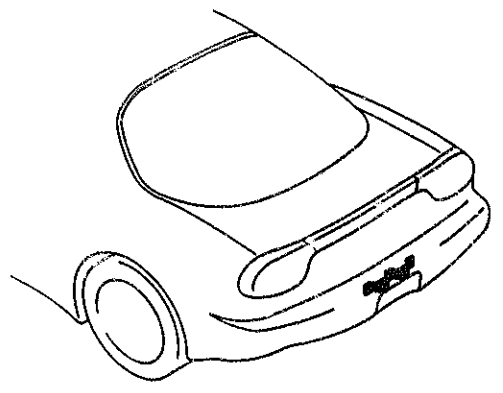

PART NO.	QTY	MODEL/RESTRICTION	MODEL/RESTRICTION	MODEL/RESTRICTION	FROM-TO
51-270 FD01-51-270C	1	LAMP, LICENSE			
51-271 FD01-51-261A	1	BRACKET, LICENSE LAMP			
51-273 G225-51-274b	2	LENS, LICENSE LAMP			
51-273A G225-51-273	2	GASKET, LICENSE			
51-293A FD01-51-293	2	COVER, LICENSE LAMP			
69-170K 99701-6050	2	BULB, INTERIOR MIRROR 12V SW			
76-724 8092-51-833	3	RIVET			

5125 -1 * INTERIOR LAMPS

5125 INTERIOR LAMPS

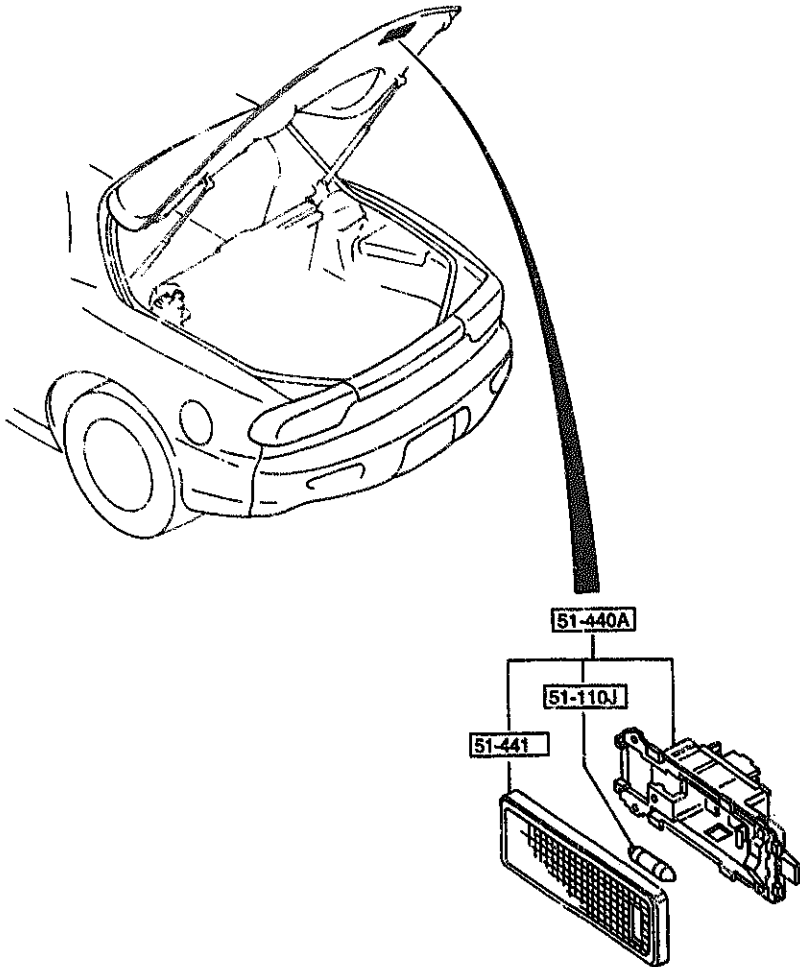

PART NO.	QTY	MODEL/RESTRICTION	MODEL/RESTRICTION	MODEL/RESTRICTION	FROM-TO
51-110J		BULB			
99700-5080	1	12V/8W			
51-440A		LAMP,CARGO ROOM			
LA01-51-440	1				
51-441		LENS			
9225-51-441	1				

5130 OVERHEAD CONSOLE

(STEEL SUN-RF)
(GLASS SUN-RF)

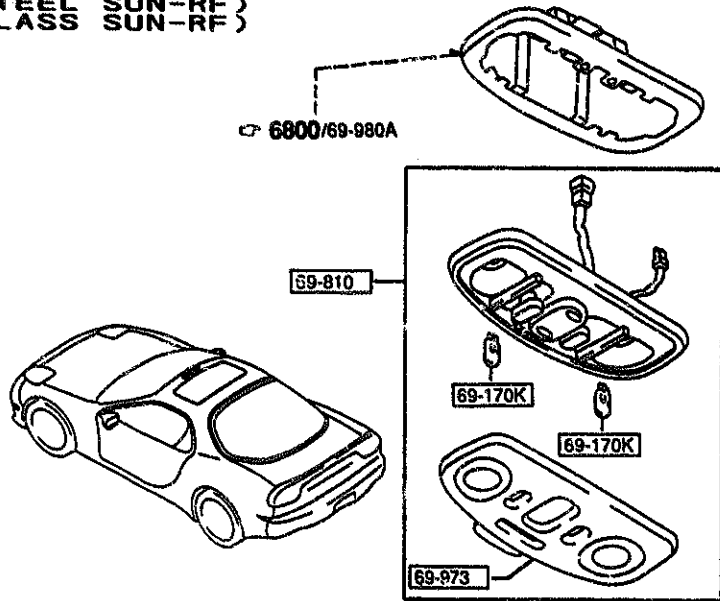

(W/O SUN-RF)

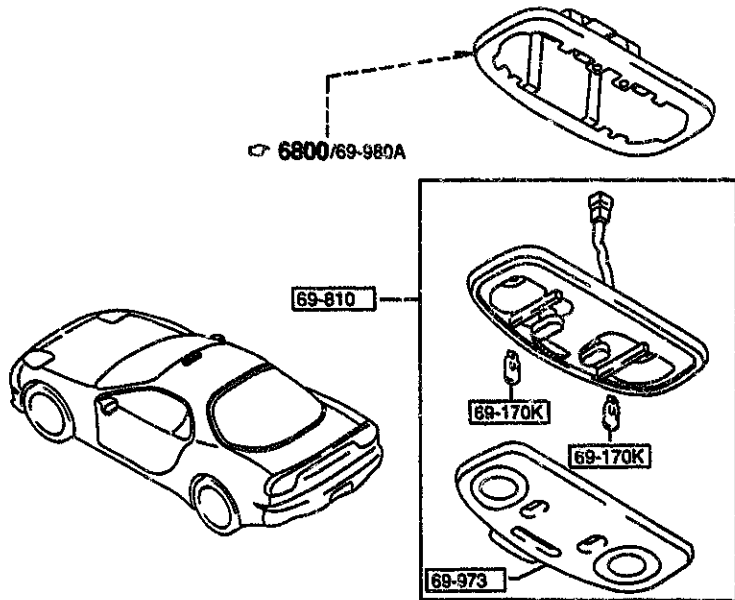

5130 -1 * OVERHEAD CONSOLE

PART NO.	QTY	MODEL/RESTRICTION	MODEL/RESTRICTION	MODEL/RESTRICTION	FROM-TO
69-170K		BULB, INTERIOR MIRROR			
99701-6050	2	12V 5W			
69-810		CONSOLE, OVERHEAD			
FD01-69-970C	1	(STEEL SUN-RF) (GLASS SUN-RF)			-3A01
02	INT-	FES FE6 FE7 BLACK			
FD03-69-970C	1	(W/O SUN-RF)			-3A01
02	INT-	FES FE6 FE7 BLACK			
FD01-69-970D	1	(STEEL SUN-RF) (GLASS SUN-RF)			3A01-
02	INT-	FES FE6 FE7 BLACK			
FD03-69-970D	1	(W/O SUN-RF)			3A01-
02	INT-	FES FE6 FE7 BLACK			
69-973		LENS, OVERHEAD CONSOL E			
FD02-69-973	1	(W/O SUN-RF)			-3A01
FD05-69-973	1	(STEEL SUN-RF) (GLASS SUN-RF)			-3A01
EA01-69-973	1	(W/O SUN-RF)			3A01-
EA05-69-973	1	(STEEL SUN-RF) (GLASS SUN-RF)			3A01-
3A01 FD333*-300888					

AUFA05

CAT. AUFA05-03

1995-03

5170 ORNAMENTS

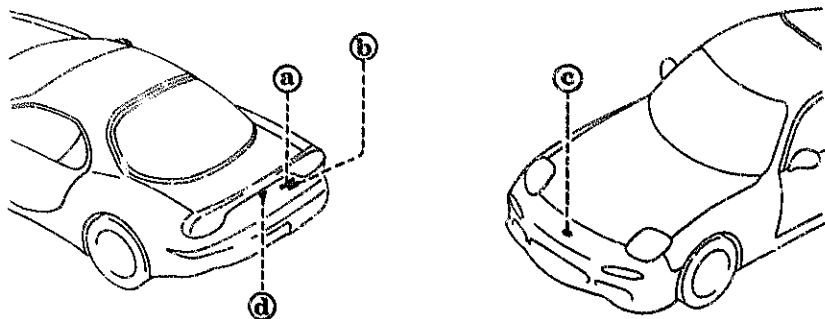

PART NO.	QTY	MODEL/RESTRICTION	MODEL/RESTRICTION	MODEL/RESTRICTION	FROM-TO
51-711B FD01-51-711A	1	ORNAMENT, MAKER NAME-REAR			
51-720 FD01-51-721C	1	ORNAMENT, CAR NAME-REAR			
51-740 FD02-51-731	1	MASCOT, FRONT			
51-741A FD02-51-741A	1	MASCOT, REAR			

5180 COWL & EXTRACTOR GRILLES

5180 -1 COWL & EXTRACTOR GRILLES

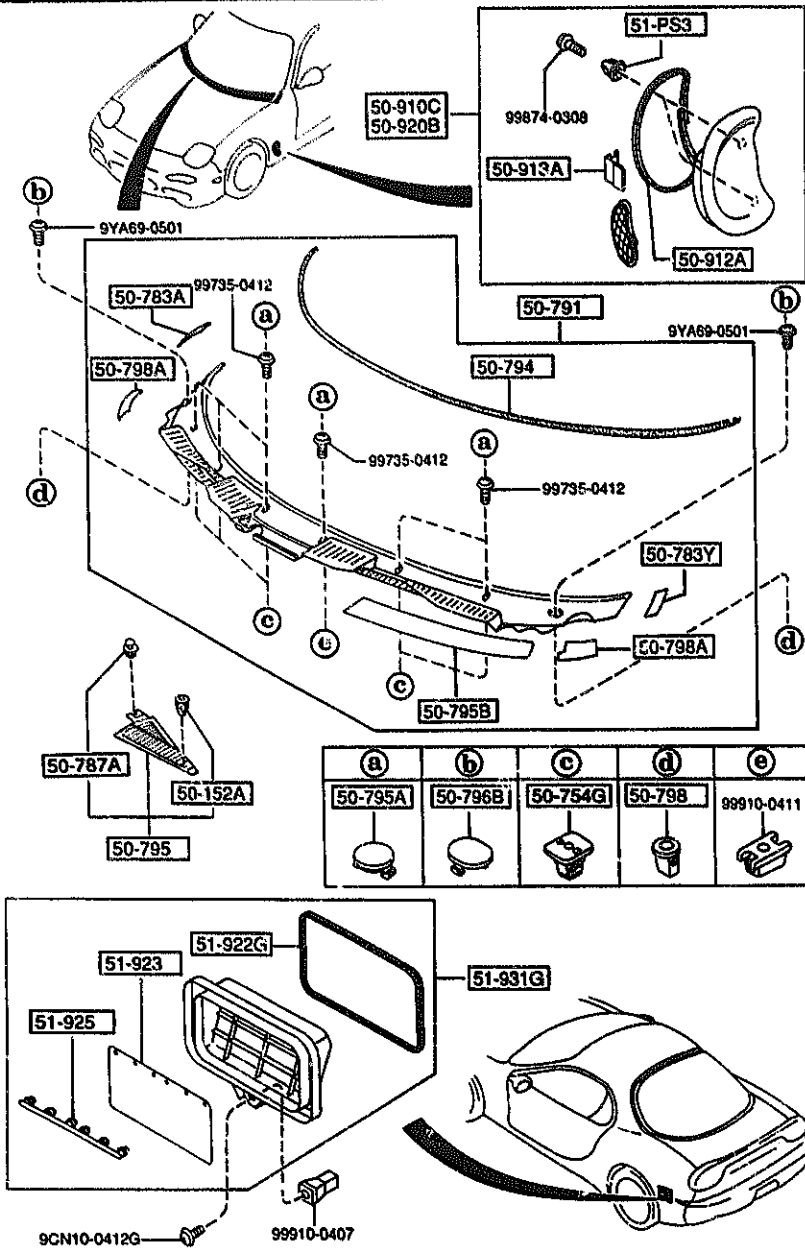

PART NO.	QTY	MODEL/RESTRICTION	MODEL/RESTRICTION	MODEL/RESTRICTION	FROM-TO
50-152A		CLIP			
3597-50-152	1				
50-754G		GROMMET, SCREW			
B482-50-792	5				
50-783A		PROTECTOR(R), COWL GRILLE			
FD01-50-783	1				
50-783Y		PROTECTOR(L), COWL GRILLE			
FD01-50-793	1				
50-787A		FASTENER			
B252-51-PJ5A	1				
50-791		GRILLE, COWL			
FD01-50-790A	1				
50-794		PROTECTOR			
FD01-50-794A	1				
50-795		BAFFLE, COWL			
FD01-50-7P0	1				
50-795A		CAP			
GA78-50-795	6				
50-795B		PROTECTOR, COWL GRILLE			
FD01-50-795	1				
50-796B		CAP			
E016-50-796	2				
50-798		SCREW, GROMMET			
FD02-50-798	2				
50-798A		PROTECTOR, COWL GRILLE			
FD01-50-798	2				
50-910C		GRILLE(R), FENDER			
FDV2-50-91XB	1				

AUFA05

CAT. AUFA05-03

1995-03

2-H12

5180 COWL & EXTRACTOR GRILLES

5180 -2 * COWL & EXTRACTOR GRILLES

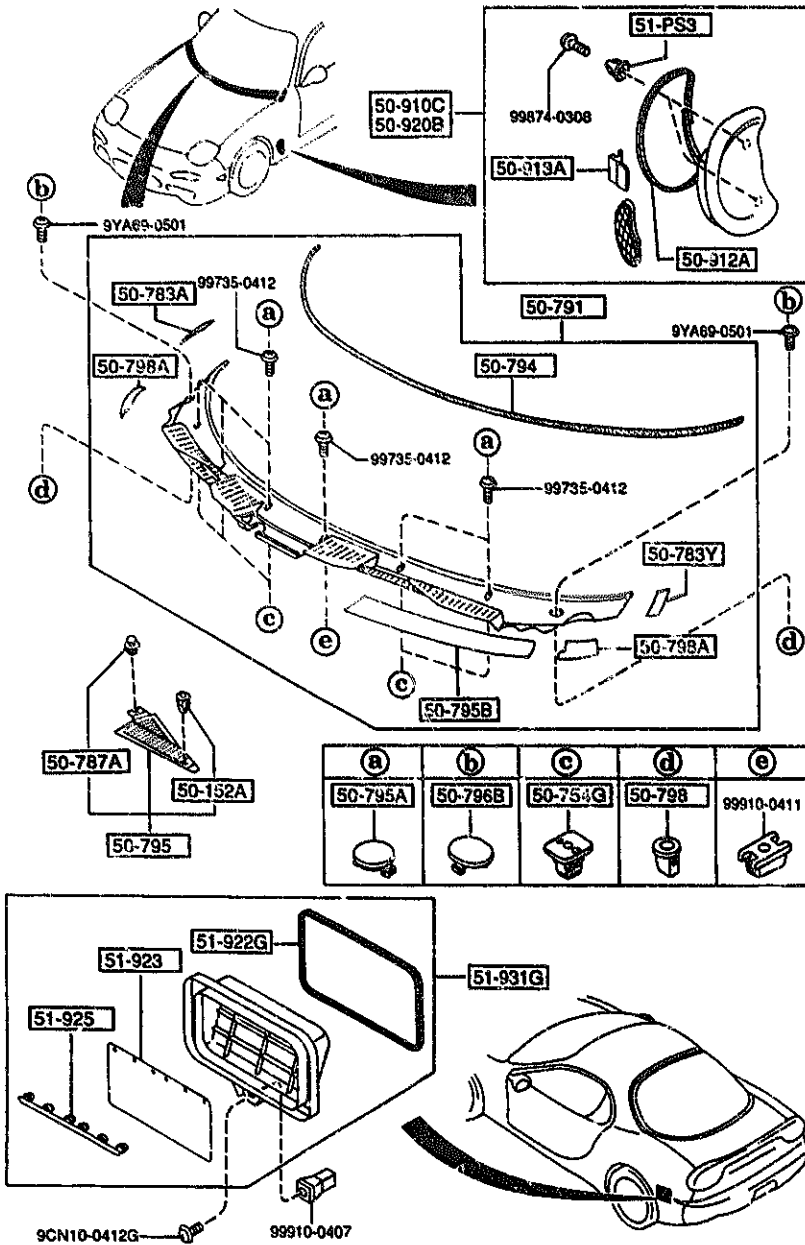

PART NO.	QTY	MODEL/RESTRICTION	MODEL/RESTRICTION	MODEL/RESTRICTION	FROM-TO
50-912A	2	PROTECTOR, FENDER GRILLE			
FD01-50-912					
50-913A	2	CLIP, FENDER GRILLE			
FD01-50-913					
50-920B	1	GRILLE(L), FENDER			
FDY2-50-92XB					
51-PS3	4	CLIP			
FD01-51-PS3					
51-922G	1	GASKET, CHAMBER-EXTRACTOR			
FD01-51-922A					
51-923	1	VALVE, EXTRACT CHAMBER			
FD01-51-923					
51-925	1	RETAINER, CHAMBER-EXTRACTOR			
FD01-51-924					
51-931G	1	CHAMBER, EXTRACTOR			
FD01-51-920B					

AUFA05

-200-

CAT. AUFA05-03

1995-03

5230 -1 BONNET

5230 BONNET

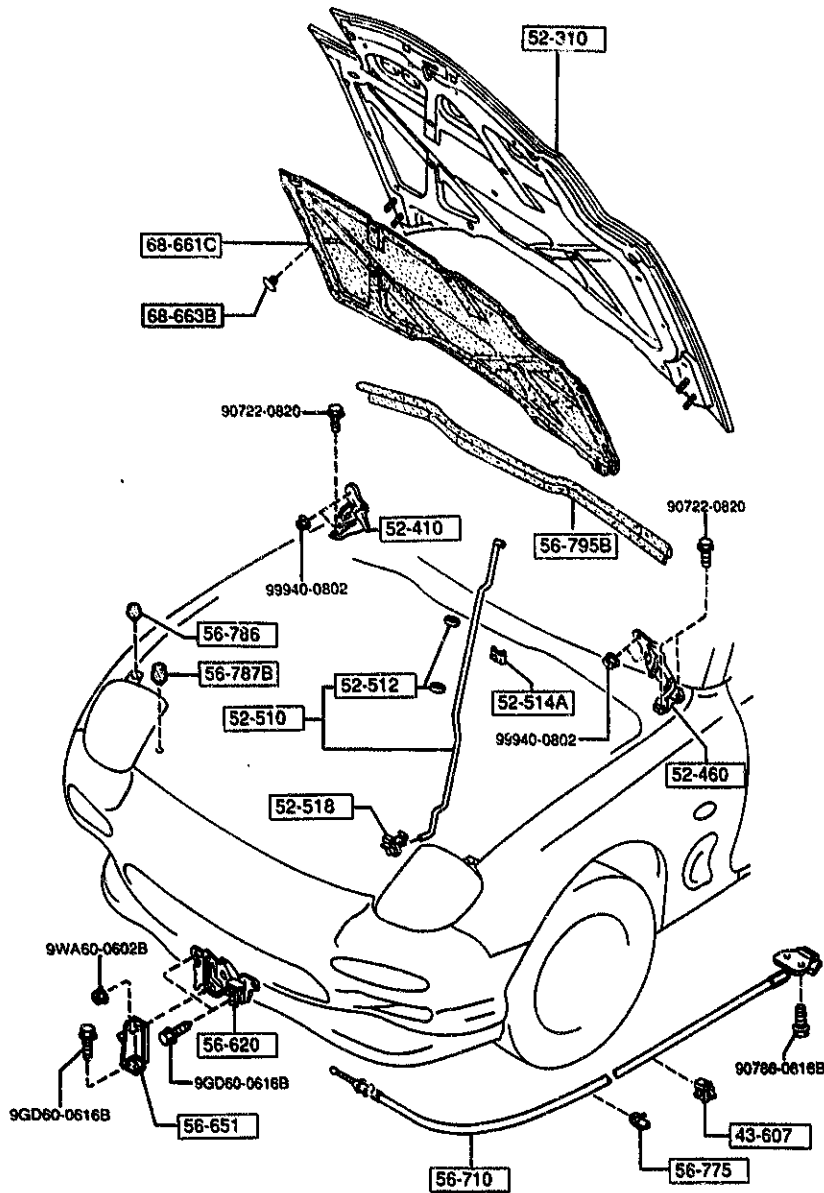

PART NO.	QTY	MODEL/RESTRICTION	MODEL/RESTRICTION	MODEL/RESTRICTION	FROM TO
43-607		CLIP,RR BRAKE PIPE			
0309-43-607	1				
52-310		BONNET			
FD01-52-310G	1				
52-410		HINGE(R), BONNET			
FD01-52-410B	1				
52-460		HINGE(L), BONNET			
FD01-52-420B	1				
52-510		STAY, BONNET			
FD01-56-650	1				
52-512		SPACER, BONNET STAY			
FB01-52-512	2				
52-514A		HOLDER, BONNET STAY-S			
FD01-56-642	1	HROUD			
52-518		HOLDER, BONNET STAY			
G144-52-518B	1				
56-620		LOCK, BONNET			
FD01-56-620B	1				
56-651		STAY, LOCK-BONNET			
FD01-56-67X	1				
56-710		WIRE, RELEASE-BONNET			
FD01-56-720C	1				
56-775		CLIP, WIRE-BONNET			
D001-56-731	1				
56-786		RUBBER(C), CUSHION-BONNET			
FB01-56-786A	2				
56-787B		RUBBER, CUSHION-BONNET FRT			
FB01-56-787A	2				
-4401					
4401 FB333M-303310					

AUFA05

CAT. AUFA05-03

1995-03

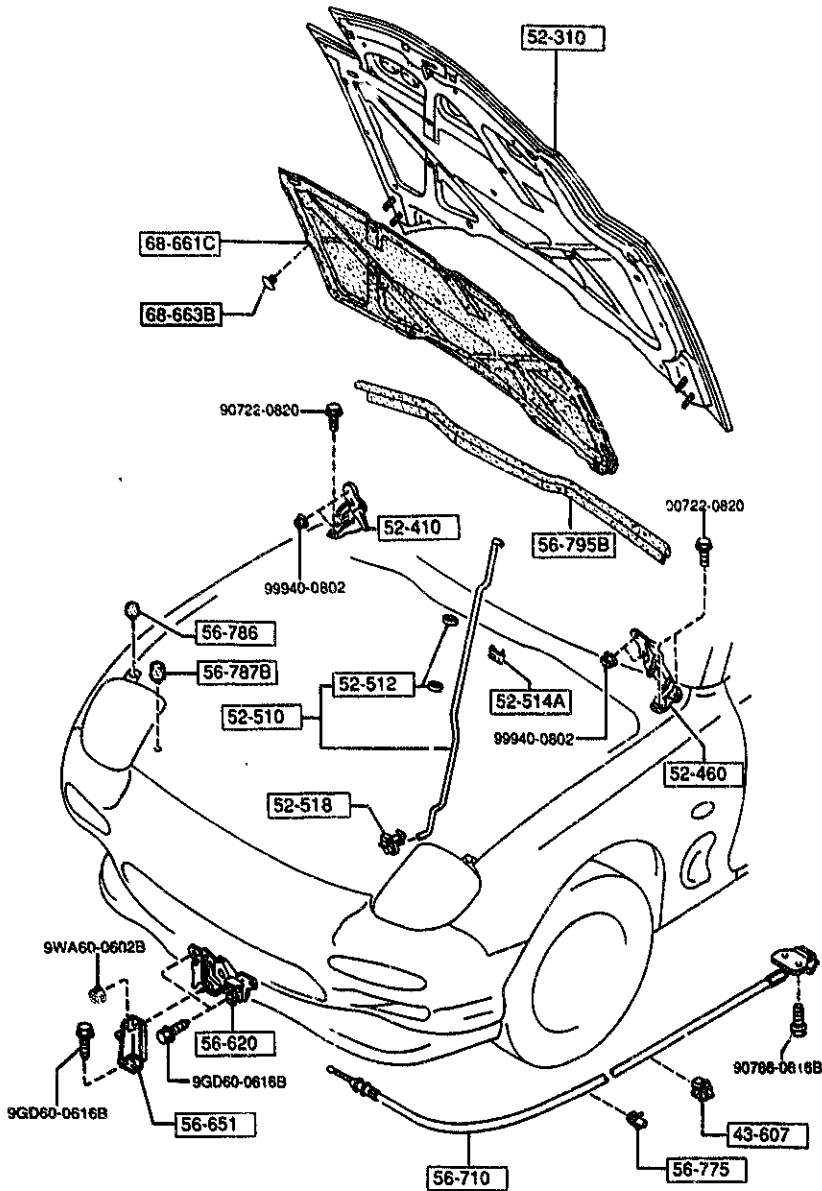

PART NO.	QTY	MODEL/RESTRICTION	MODEL/RESTRICTION	MODEL/RESTRICTION	FROM-TO
CONT'D					
A (FB01-56-787B)					
FB01-56-787B	2				4401-
----- 56-795B -----		WEATHERSTRIP, BONNET-REAR			
FD01-56-760B	1				
----- 68-661C -----		INSULATOR, BONNET			
FD01-68-601B AN(FD01-68-601C)	1				-3901
FD01-68-601C	1				3901-
----- 68-663B -----		FASTENER, BONNET			
GA2A-56-694	13				
3901 FD333*-300438 4401 FD333*-303310					

AUFA05

CAT. AUFA05-03

1995-03

5310 FRONT PANELS

5310 -1 * FRONT PANELS

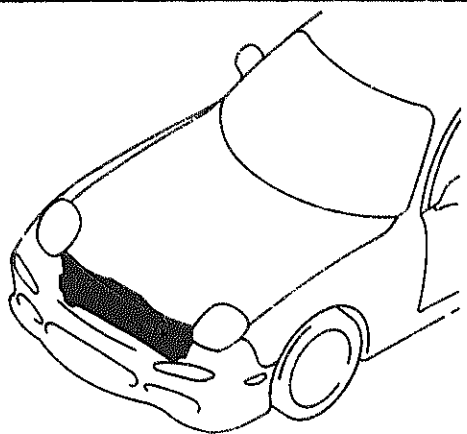

53-162

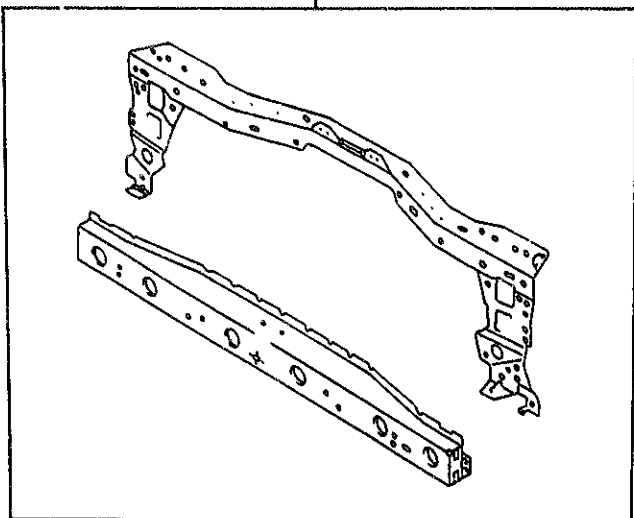

PART NO.	QTY	MODEL/RESTRICTION	MODEL/RESTRICTION	MODEL/RESTRICTION	FROM-TO
53-162 FDD1-53-150A	1	MEMBER,CROSS			

5320 -1 FENDER & WHEEL APRON PANELS

5320 FENDER & WHEEL APRON PANELS

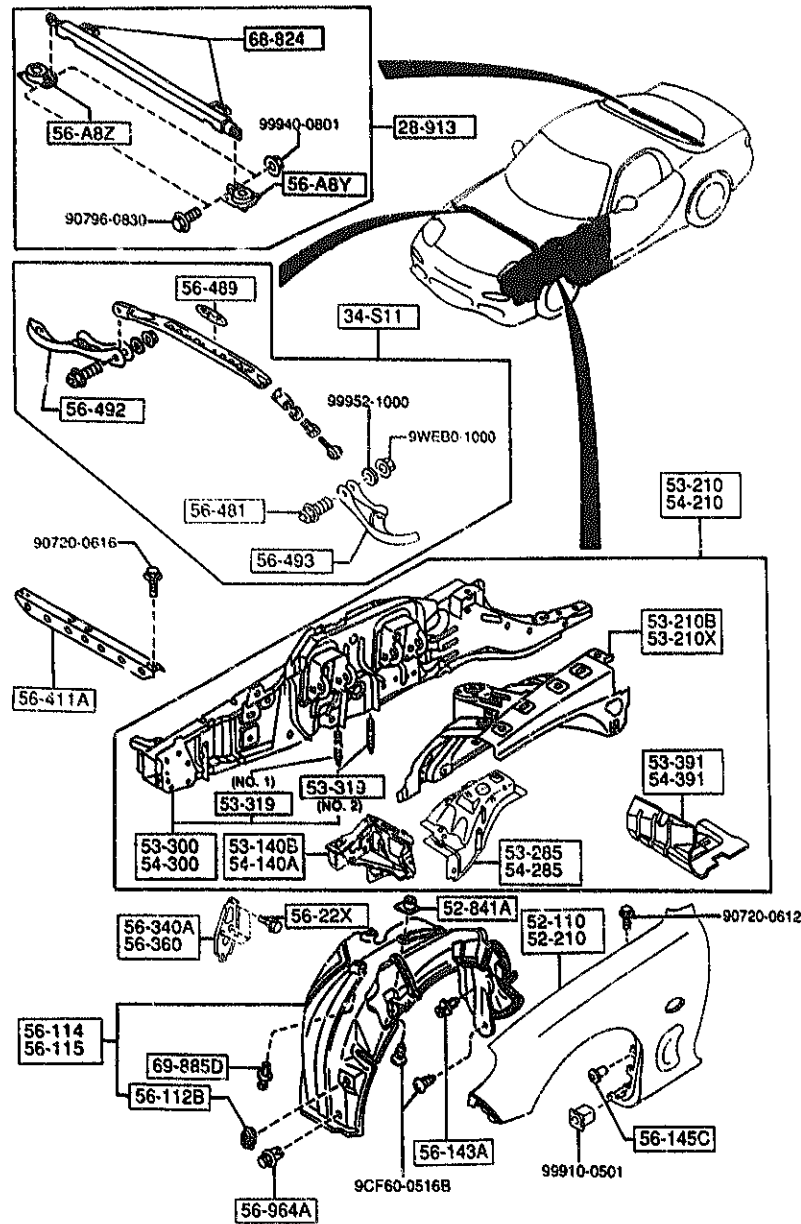

PART NO.	QTY	MODEL/RESTRICTION	MODEL/RESTRICTION	MODEL/RESTRICTION	FROM-TO
28-913		BAR, STRUT			
FD15-56-38Y	1				
34-S11		BAR, STRUT			
F111-56-48Z	1	(HARD SUSP)			
52-110		PANEL (R), FENDER-FRT.			
FD01-52-111D	1				
52-210		PANEL (L), FENDER-FRT.			
FD01-52-211D	1				
52-841A		NUT, CLIP			
B455-56-135	6				
53-140B		PANEL (R), SHROUD-SIDE			
FD01-53-12XJ	1				
53-210		PANEL (R), WHEEL APRON			
FD01-53-200A	1				
53-210B		PANEL (R), WHEEL APRON			
F901-53-210E	1				
53-210X		PANEL (L), WHEEL APRON			
FD01-54-210F	1				
53-285		REINF. (R), WHL. APRON			
FD01-53-270A	1				
53-300		FRAME (R), SIDE-FRONT			
FD01-53-300M	1				
53-319		BOLT, MOUNT-MEMBER			
FD01-53-317A	2	(ILLUST. NO. 1)			
FD01-53-318	2	(ILLUST. NO. 2)			
53-391		BOX (R), TORQUE			
FD01-53-391	1				

AUFA05

CAT. AUFA05-03

1995-03

5320 FENDER & WHEEL APRON PANELS

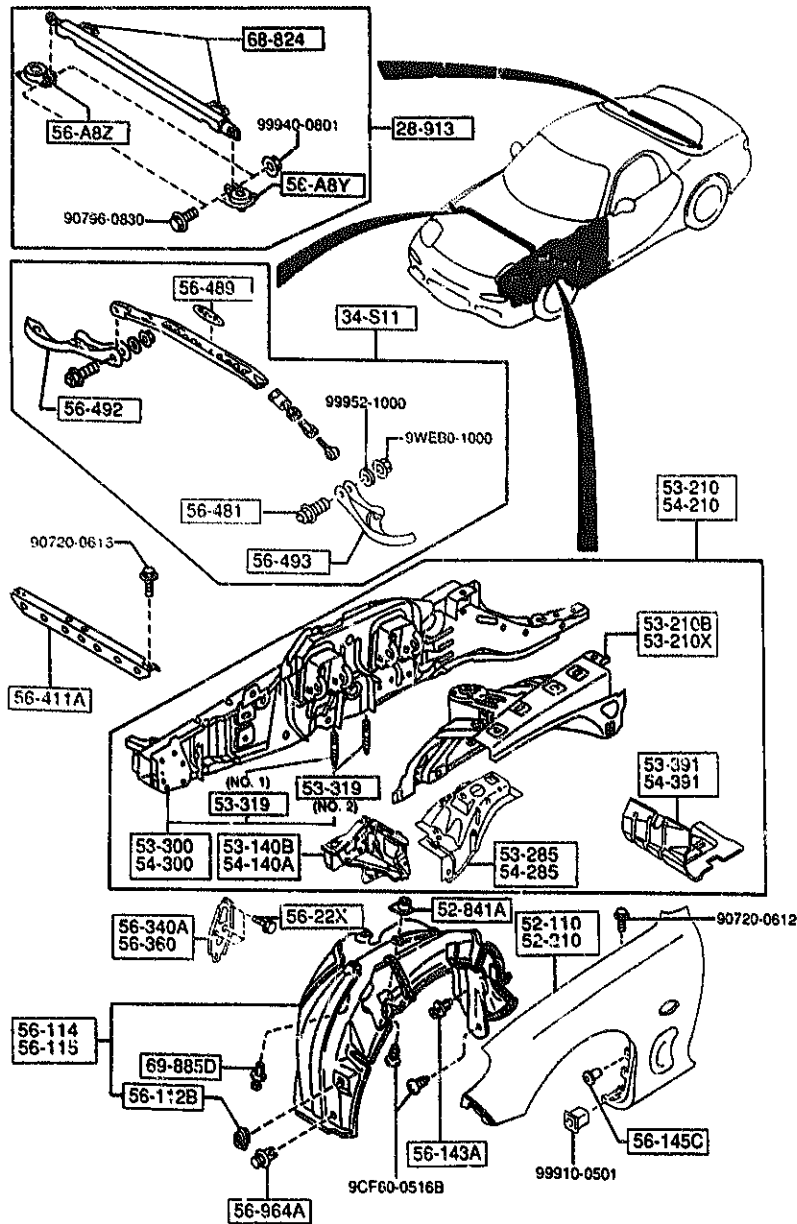

PART NO.	QTY	MODEL/RESTRICTION	MODEL/RESTRICTION	MODEL/RESTRICTION	FROM TO
54-140A		PANEL(L),SHROUD-SIDE			
FD01-54-12XJ	1				
54-210		PANEL(L),WHEEL APRON			
FD01-54-200A	1				
54-285		REINF.(L),WHL. APRON			
FD01-54-270A	1				
54-300		FRAME(L),SIDE-FRONT			
FD01-54-300N	1				
54-391		BOX(L),TORQUE			
FD01-54-391	1				
56-ABY		BRKT(L),STRUT BAR			
FD01-56-ABY	1				
56-ABZ		BRKT(R),STRUT BAR			
FD01-56-ABZ	1				
56-112B		PLUG,DRAIN			
B092-56-053	2				
56-114		GUARD(R),MUD			
FD01-56-130G	1				-3B02
FD01-56-130H	1				3B02-
56-115		GUARD(L),MUD			
FD01-56-140G	1				-3B02
FD01-56-140H	1				3B02-
56-143A		RIVET,MUD GUARD			
B455-56-143	2				
56-145C		CLIP,MUD GUARD			
B455-56-145	2				
56-22X		BOLT,TIE DOWN HOOK-FRONT			
FB01-56-22X	6				
3B02 FD333X-301137					

5320 FENDER & WHEEL APRON PANELS

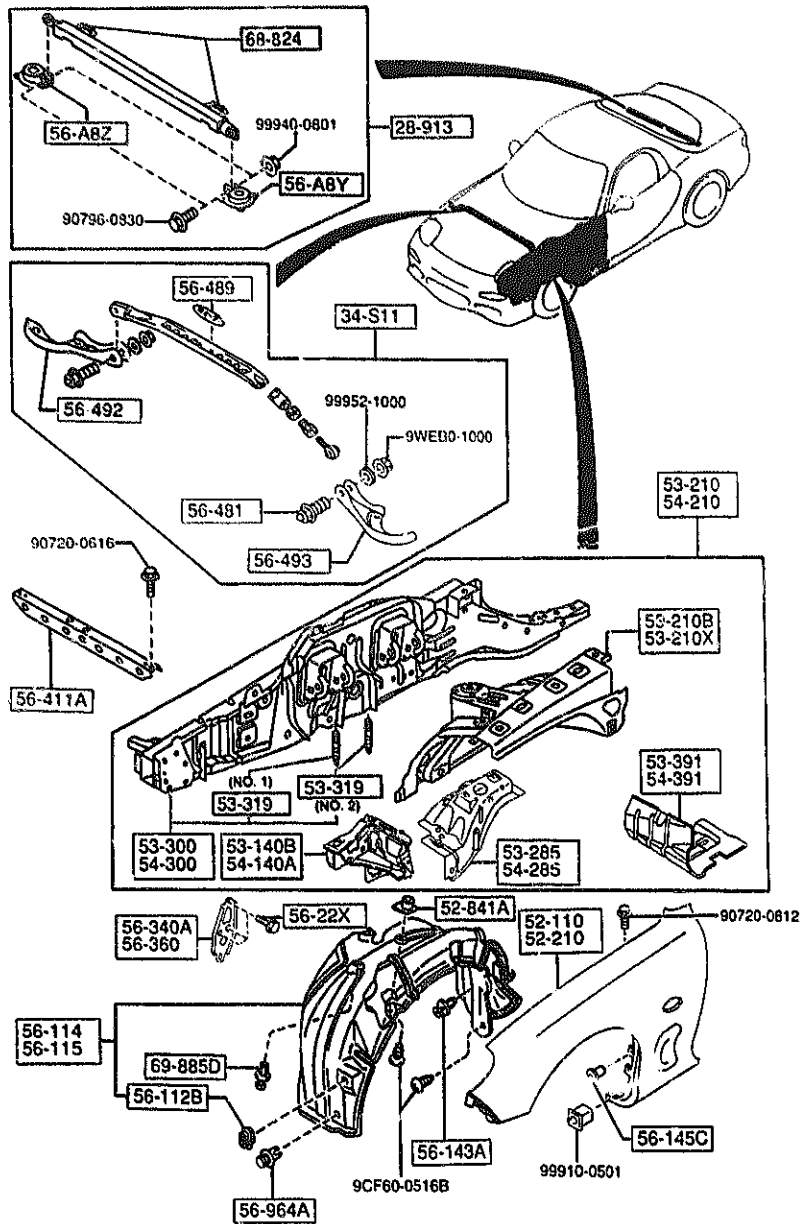

PART NO.	QTY	MODEL/RESTRICTION	MODEL/RESTRICTION	MODEL/RESTRICTION	FROM-TO
56-340A		HOOK(R),TIE DOWN-FRO NT			
FD01-56-221	1				
56-360		HOOK(L),TIE DOWN-FRO NT			
FD01-56-231	1				
56-411A		MEMBER,CROSS			
FD01-56-290A	1				
56-481		BOLT,STRUT BAR			
FD03-56-491	2 (HARD SUSP)				
56-489		PLATE,LOGO-STRUT BAR			
FD03-56-489	1 (HARD SUSP)				
56-492		PLATE(R),STRUT BAR			
FD11-56-482	1 (HARD SUSP)				
56-493		PLATE(L),STRUT BAR			
FD03-56-483A	1 (HARD SUSP)				
56-964A		RIVET,SEAL PLATE-SHR OD			
FB01-56-964	6				
68-824		HINGE			
FD01-68-305	2				
69-885D		FASTENER			
NA01-56-145	16				

5330 -1 * DASH & COWL PANELS

5330 DASH & COWL PANELS

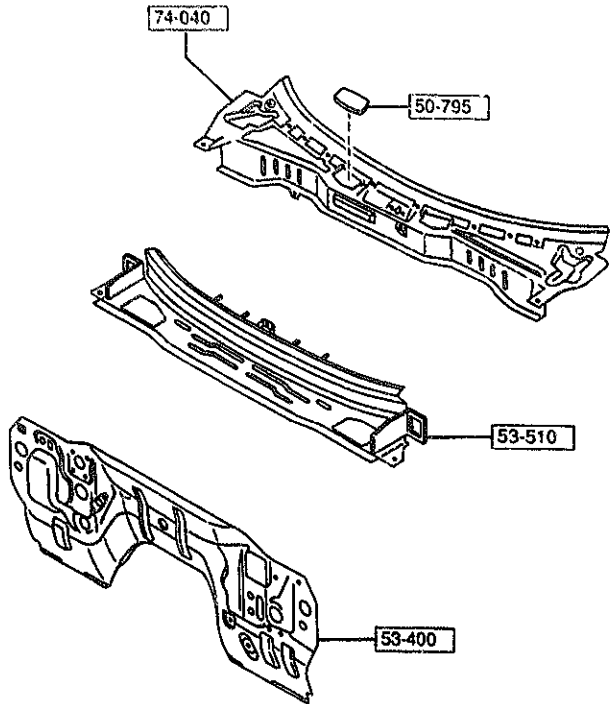
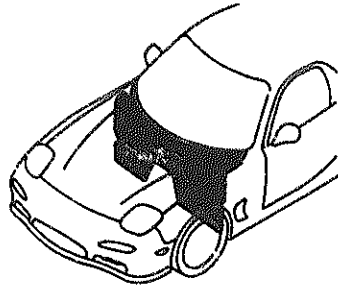

PART NO.	QTY	MODEL/RESTRICTION	MODEL/RESTRICTION	MODEL/RESTRICTION	FROM-TO
50-795 FD01-56-351	1	BAFFLE,COWL			
53-400 FD01-54-400E	1	PANEL,DASH-LOWER (W/O SUN-RF) (STEEL SUN-RF)			
FD04-54-400E	1	(GLASS SUN-RF)			
53-510 FD15-53-510	1	PANEL,DASH-UPPER			
74-040 FD01-70-610A	1	PANEL,COWL			

5340 SIDE PANELS

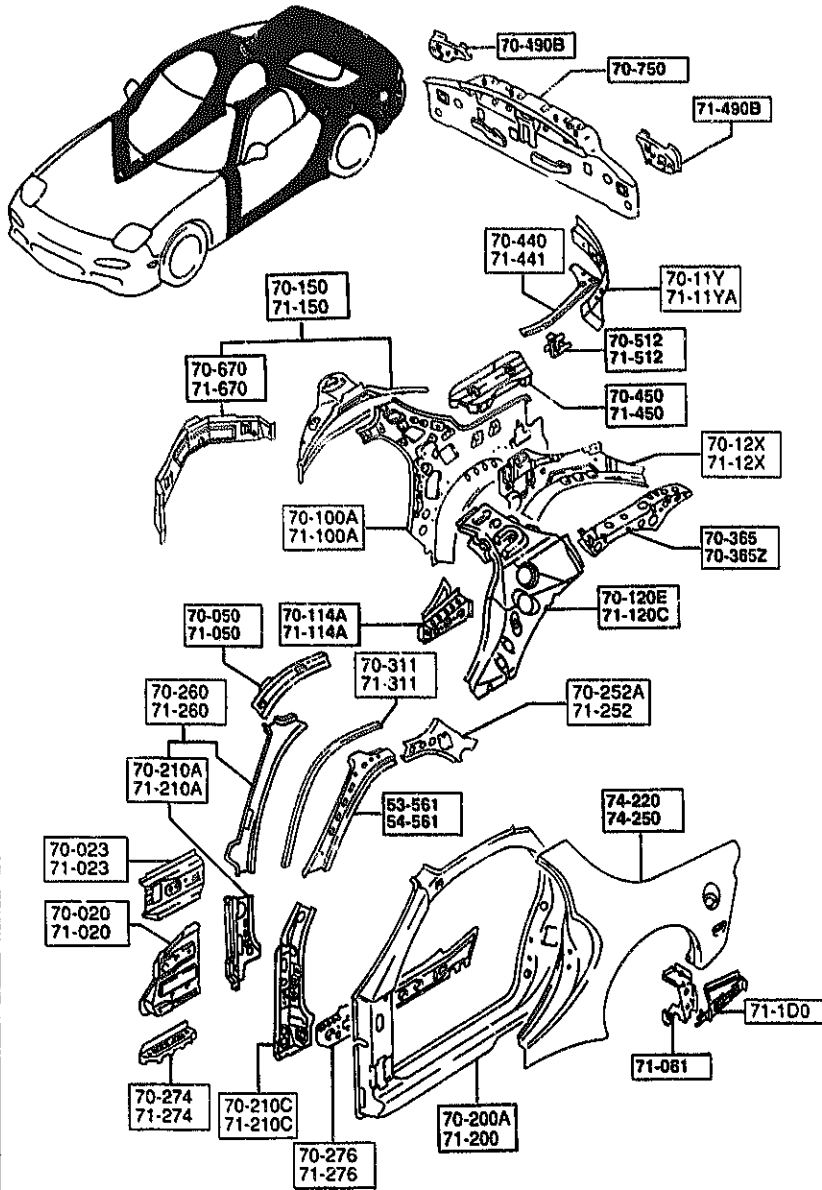

PART NO.	QTY	MODEL/RESTRICTION	MODEL/RESTRICTION	MODEL/RESTRICTION	FROM-TO
53-561 FD01-70-242B	1	REINF.(R),F. PILLAR INNER			
54-561 FD01-71-242B	1	REINF.(L),F. PILLAR INNER			
70-020 FD01-70-020B	1	PANEL(R),COWL SIDE			
70-023 FD01-70-651A	1	REINF.(R),COWL SIDE			
70-050 FD01-70-050	1	RAIL(R),ROOF-INNER			
70-100A FD01-70-110A	1	PANEL(R),REAR PILLAR			
70-11V FD01-70-11V	1	PILLAR'C'(R),REAR-IN NER			
70-114A FD15-70-11Z	1	JUNCTION(R),CORNER-Q /PANE			
70-12X FD01-70-12XA	1	REINF.(R),SUSPENSION HSG			
70-120E FD01-70-120B	1	REINF.(R),REAR PILLA R IN.			
70-150 FD01-70-150D	1	PANEL(R),WHEEL HOUSE			
70-200A FDY1-70-200	1	FRAME(R),SIDE-OUTER			
70-210A FD01-70-230A	1	PILLAR(R),HINGE			
70-210C FD01-70-030D	1	REINF.(R),HINGE			

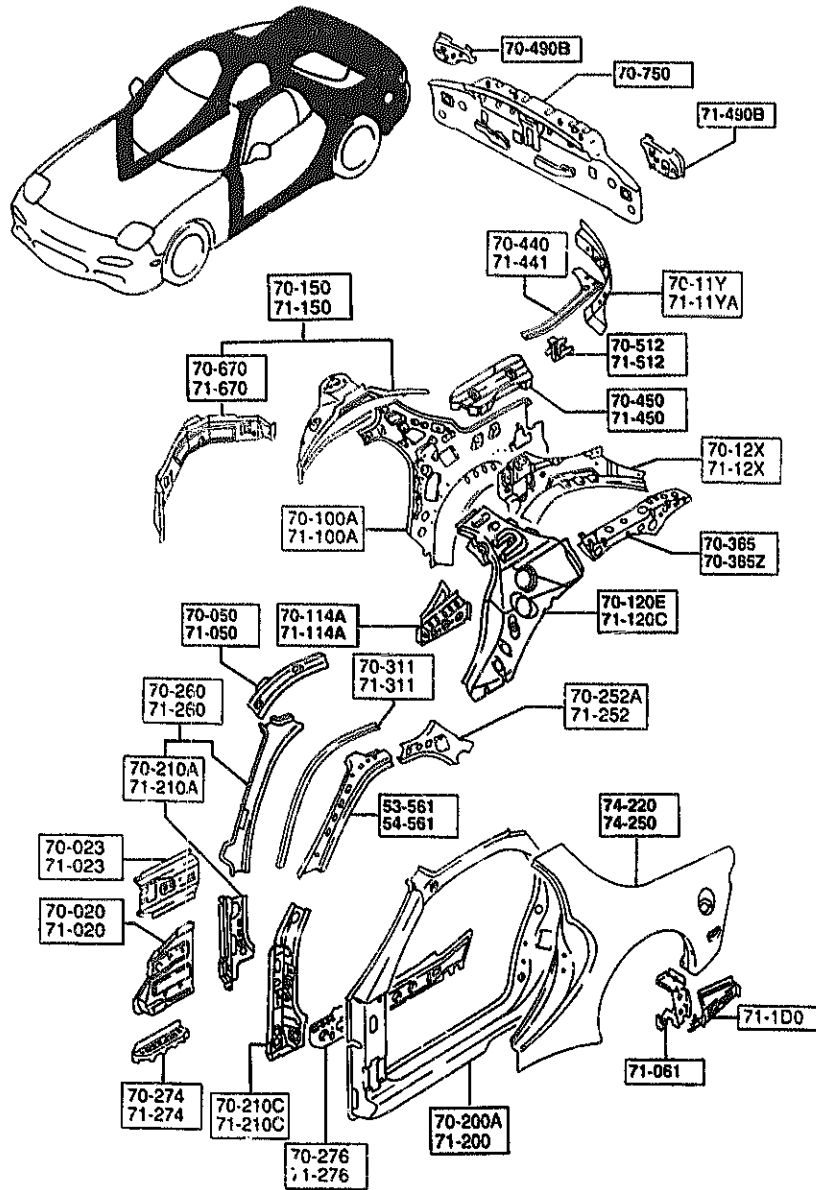

PART NO.	QTY	MODEL/RESTRICTION	MODEL/RESTRICTION	MODEL/RESTRICTION	FROM-TO
70-252A	1	REINF.(R),ROOF RAIL			
FD01-70-252A					
70-260	1	PILLAR(R),FRT.-INNER			
FDY1-70-24X		(W/O SUN-RF)			
FDY4-70-24X		(STEEL SUN-RF)			
		(GLASS SUN-RF)			
70-274	1	GUSSET(R),SIDE SILL			
FD01-70-274A		OUTER			
70-276	1	REINF.(R),SIDE SILL			
FD01-70-272B					
70-311	1	RAIL(R),RAIN			
FD01-70-311A					
70-365	1	REINF.(R),BELT LINE-			
FD01-70-130A		C.PIL			
70-365Z	1	REINF.(L),BELT LINE-			
FD01-71-131A		C.PIL			
70-440	1	PLATE(R),CORNER			
FD01-70-440B					
70-450	1	PANEL(R),FLOOR SIDE			
FD01-70-1X1					
70-490B	1	BRACKET(R),LAMP			
FD01-70-490B					
70-512	1	BRACKET(R),TRIM-QTR			
FD01-70-119		PANEL			
70-670	1	PLATE(R),CLOSING-QTR			
FD01-70-15XC		PANEL			
70-750	1	PANEL,REAR END			
FD01-70-750C					

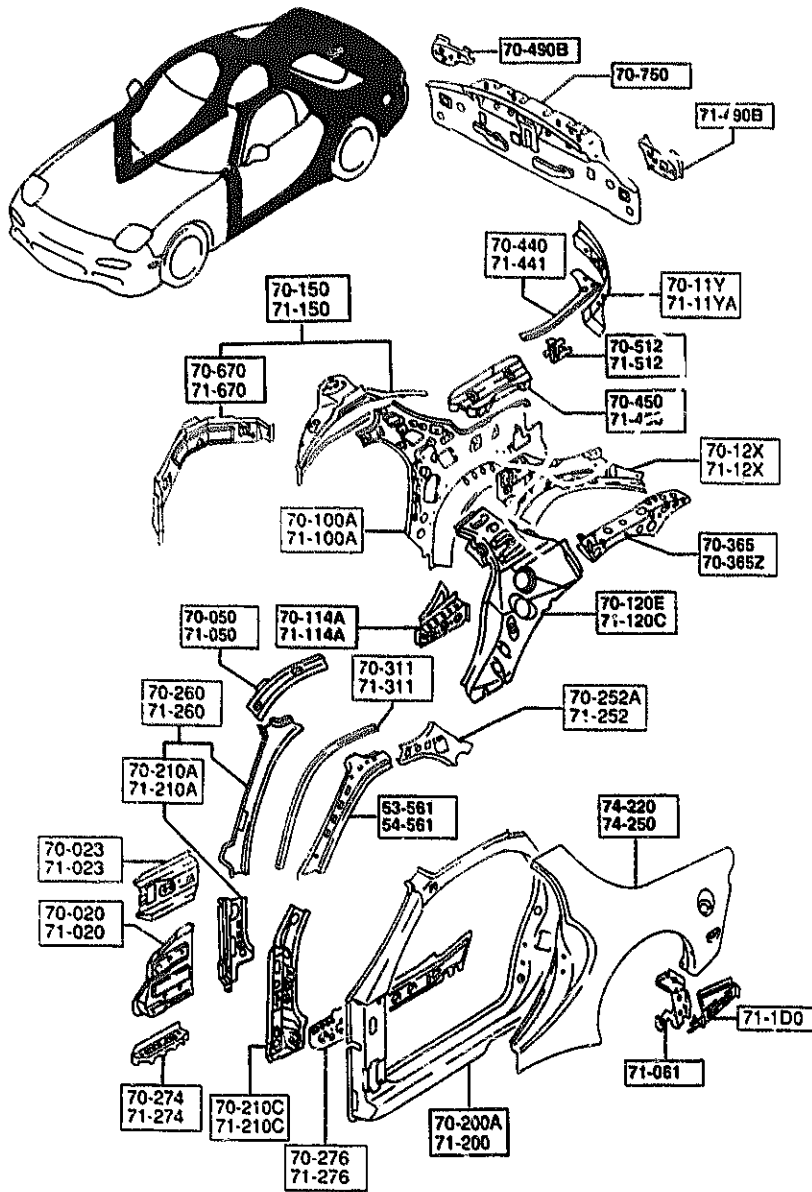

PART NO.	QTY	MODEL/RESTRICTION	MODEL/RESTRICTION	MODEL/RESTRICTION	FROM-TO
71-252		REINF.(L),ROOF RAIL			
FD01-71-252A	1				
71-260		PILLAR(L),FRT.-INNER			
FDY1-71-24X	1	(W/O SUN-RF)			
FDV4-71-24X	1	(STEEL SUN-RF) (GLASS SUN-RF)			
71-274		GUSSET(L),SIDE SILL OUTER			
FD01-71-274A	1				
71-276		REINF.(L),SIDE SILL			
FD01-71-272B	1				
71-311		RAIL(L),RAIN			
FD01-71-311A	1				
71-441		PLATE(L),CORNER			
FD01-71-440R	1				
71-450		PANEL(L),FLOOR SIDE			
FD01-71-1X1	1				
71-490B		BRACKET(L),LAMP			
FD01-71-490B	1				
71-512		BRACKET(L),TRIM-QTR PANEL			
FD01-71-119	1				
71-670		PLATE(L),CLOSING-QTR PANEL			
FD01-71-15XD	1				
74-220		PANEL(R),FENDER-REAR			
FDY1-70-400B	1				
74-250		PANEL(L),FENDER-REAR			
FDY1-71-400B	1				

5360

ROOF PANELS
(W/O SUN ROOF)

5360 -1 * ROOF PANELS
(W/O SUN ROOF)

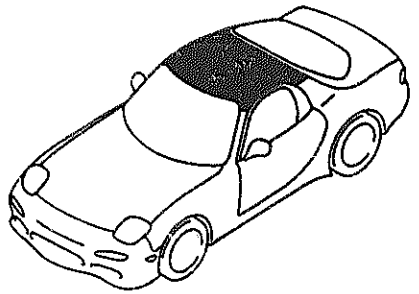
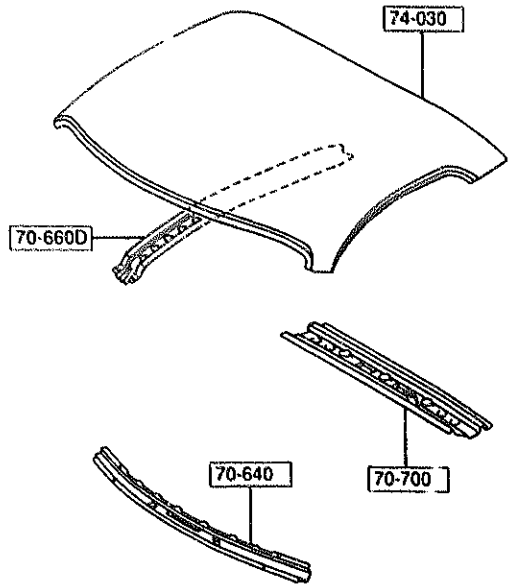

PART NO.	QTY	MODEL/RESTRICTION	MODEL/RESTRICTION	MODEL/RESTRICTION	FROM-TO
70-640		HEADER,FRONT			
F001-70-640	1				
70-660D		REINF.,ROOF			
F001-70-661	1				
70-700		HEADER,REAR			
F001-70-700B	1				
74-030		PANEL,ROOF			
F001-70-601A	1				

5360 A ROOF PANELS
(SUN ROOF)

5360 A-1 * ROOF PANELS
(SUN ROOF)

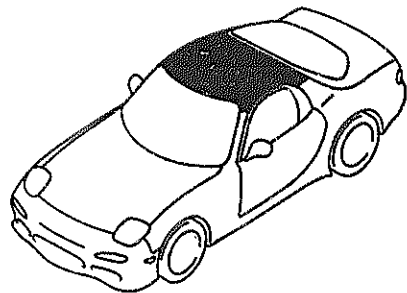
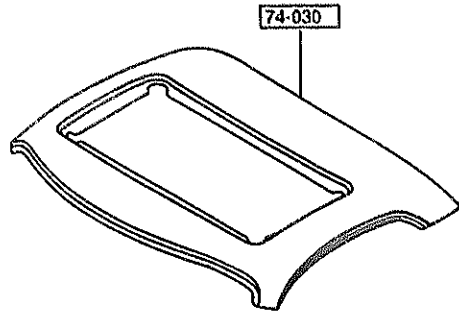

PART NO.	QTY	MODEL/RESTRICTION	MODEL/RESTRICTION	MODEL/RESTRICTION	FROM-TO
70-640		HEADER, FRONT			
FD01-70-640	1				
70-700		HEADER, REAR			
FD01-70-700B	1				
74-030		PANEL, ROOF			
FD04-70-600B	1				

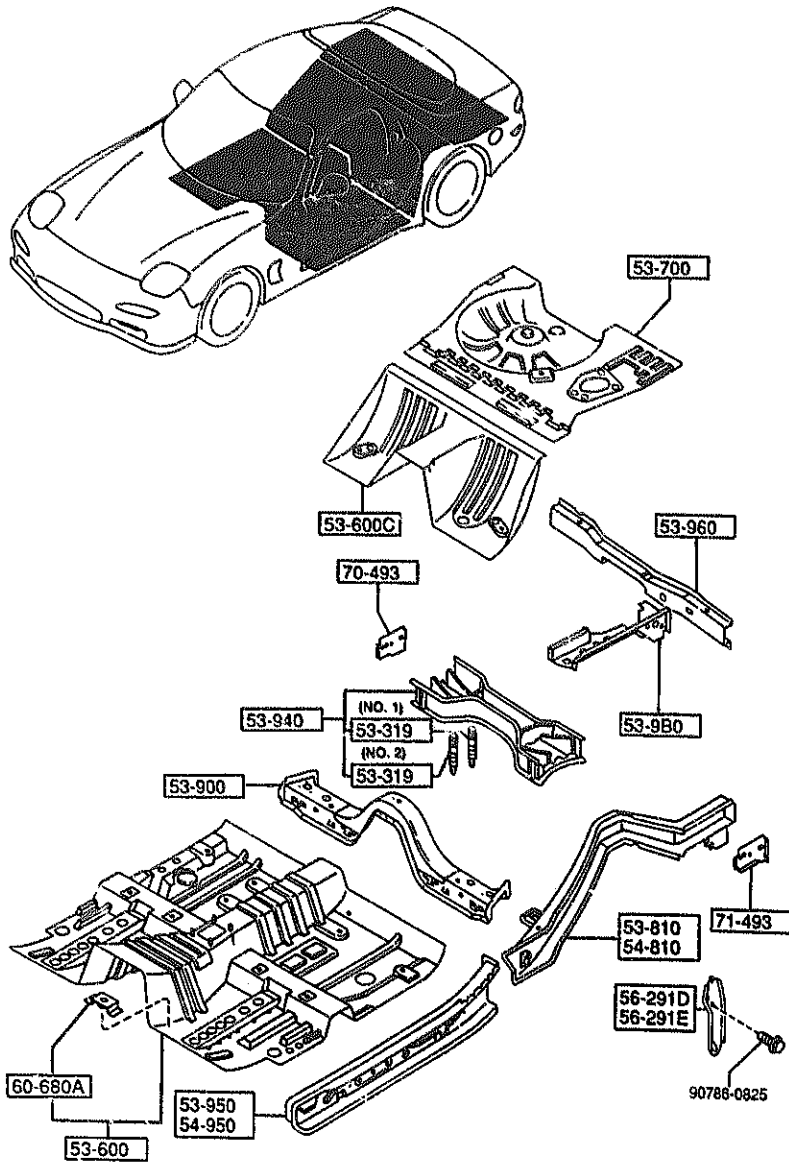

PART NO.	QTY	MODEL/RESTRICTION	MODEL/RESTRICTION	MODEL/RESTRICTION	FROM-TO
53-319		BOLT, MOUNT-MEMBER			
FD01-53-317A	2	(ILLUST. NO.1)			
FD01-53-318	2	(ILLUST. NO.2)			
53-600		PAN, FLOOR-FRONT			
FDY1-53-600A	1				
53-600C		PAN, FLOOR-CENTER			
FDY1-53-720	1				
53-700		PAN, FLOOR-REAR			
FDY1-53-710	1				
53-810		FRAME(R), REAR SIDE			
FD01-53-810E AN(FD01-53-810F)	1				-3A20
FD01-53-810F	1				3A20-
53-980		FRAME, CENTER-REAR SIDE			
FD01-53-980A	1				
53-900		MEMBER NO.3, CROSS			
FD01-53-910A AN(FD01-53-910B)	1				-3C01
FD01-53-910B	1				3C01-
53-940		MEMBER NO.4, CROSS			
FD01-53-930C	1				
53-950		PANEL(R), SIDE SILL			
FD01-53-950B	1				
53-960		MEMBER NO.5, CROSS			
FD01-53-940A	1				
54-810		FRAME(L), REAR SIDE			
FD01-54-810F AN(FD01-54-810G)	1				-3A20
FD01-54-810G AN(FD01-54-810H)	1				3A20-3B02
FD01-54-810H	1				3B02-
3A20 FD333*-301093 3B02 FD333*-301117 3C01 FD333*-301464					

AUFA05

CAT. AUFA05-03

1995-03

5370 FLOOR PANELS

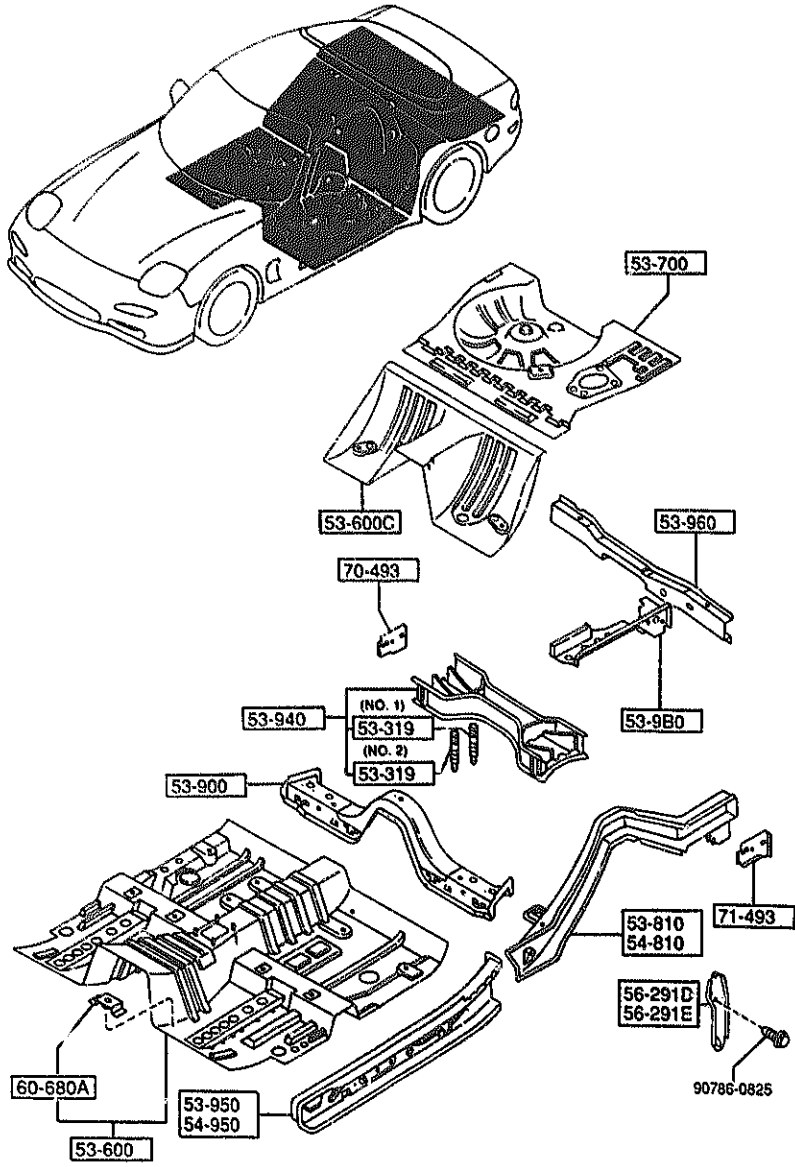

PART NO.	QTY	MODEL/RESTRICTION	MODEL/RESTRICTION	MODEL/RESTRICTION	FORM-10
54-950		PANEL(L),SIDE SEAL			
FD01-54-950A	1				
56-291D		HOOK(R),TIE DOWN			
FD01-56-251B	1				
56-291E		HOOK(L),TIE DOWN			
FD01-56-252B	1				
60-680A		BRACKET,FLOOR			
0305-53-160	2				
70-493		PLATE(R),CLOSING-R.F ENDER			
FD01-53-781B	1				
71-493		PLATE(L),CLOSING-R.F ENDER			
FD01-54-781B	1				

AUFA05

CAT. AUFA05-83

1995-03

5380 FLOOR ATTACHMENTS (HOLE COVERS)

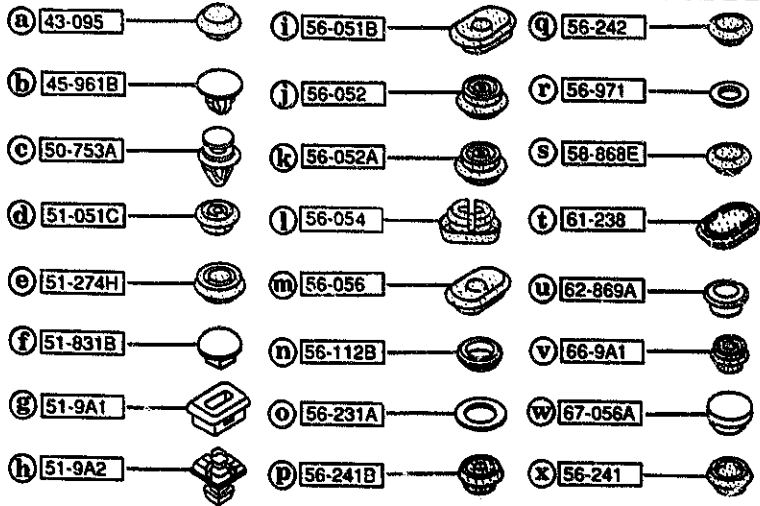
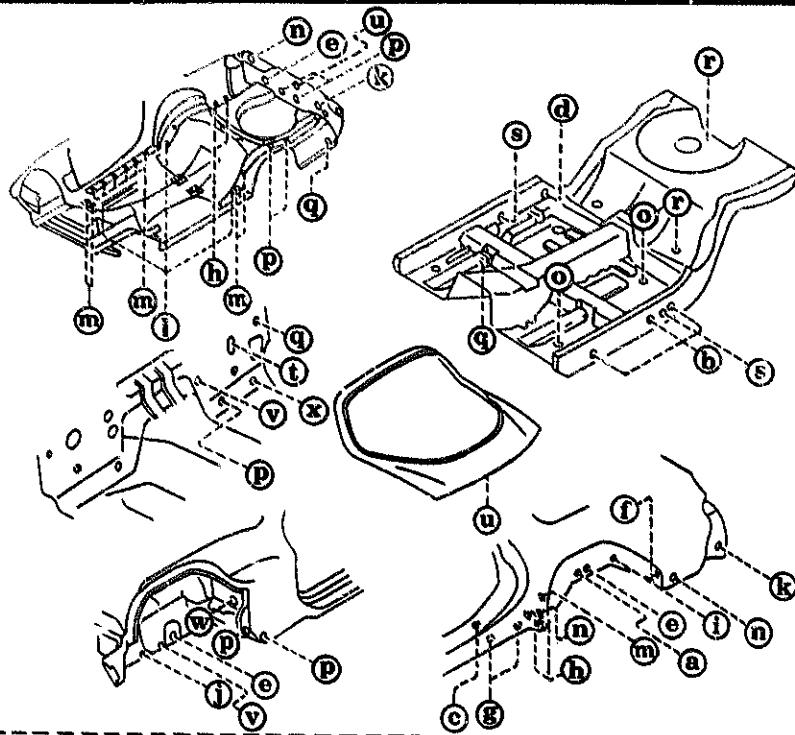

5380 -1 FLOOR ATTACHMENTS (HOLE COVERS)

PART NO.	QTY	MODEL/RESTRICTION	MODEL/RESTRICTION	MODEL/RESTRICTION	FROM-TO
43-095		GROMMET			
H001-43-095	2				
45-961B		CAP			
H002-45-961	3				
50-753A		FASTENER			
FD01-50-753	2				
51-051C		PLUG,HOLE			
BR70-51-264	1				
51-274H		GROMMET			
BF67-51-261	6				
51-831B		PLUG,HOLE-FLAP			
DA14-51-831	2				
51-9A1		PLUG*A*,BLIND-S.SPOILER			
FB03-51-9A1	4				
51-9A2		PLUG*B*,BLIND-S.SPOILER			
FB03-51-9A2	8				
56-051B		COVER,HOLE			
GA5R-56-051	2				
56-052		PLUG,DRAIN			
B092-56-052	2	D=12MM			
56-052A		PLUG,HOLE-F.SIDE FRAME			
H260-56-052	3				
56-054		PLUG,HOLE			
FD01-56-051	4				
56-056		COVER,HOLE			
GA5R-56-052	22				
56-112B		PLUG,DRAIN			

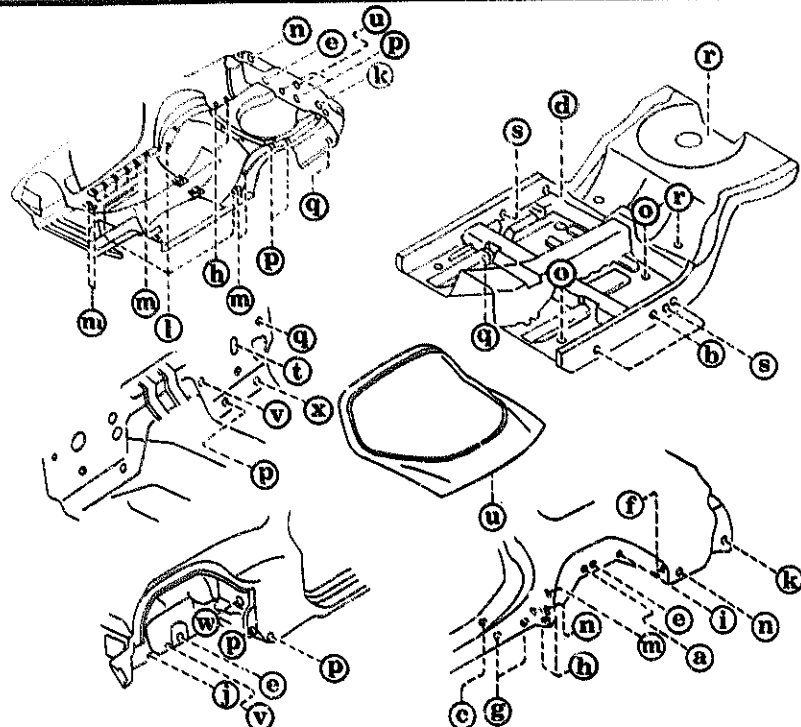

- a 43-095 i 56-051B q 56-242
- b 45-961B j 56-052 r 56-971
- c 50-753A k 56-052A s 58-868E
- d 51-051C l 56-054 t 61-238
- e 51-274H m 56-056 u 62-869A
- f 51-831B n 56-112B v 66-9A1
- g 51-9A1 o 56-231A w 67-056A
- h 51-9A2 p 56-241B x 56-241

PART NO.	QTY	MODEL/RESTRICTION	MODEL/RESTRICTION	MODEL/RESTRICTION	FROM-TO
CONT'D FB01-56-057	6				
56-231A		COVER, SERVICE HOLE			
8173-56-053	4				
56-241		PLUG, DRAIN			
0118-56-241	2	(W/O AIR CON.)			
56-241B		PLUG			
8001-56-051	10				
56-242		PLUG, DRAIN			
0118-56-242B	6				
56-971		COVER, HOLE			
0866-56-971	3				
58-868E		PLUG, SERVICE COVER			
0559-58-868	2				
61-238		GROMMET, REAR FLOOR			
H260-61-238	1				
62-869A		PLUG, DRAIN-LIFT GATE UP.			
B216-62-869	2				
66-9A1		COVER, HOLE-ANTENNA			
KA01-66-9A1	2	(W/O SUN-RF) (STEEL SUN-RF)			
KA01-66-9A1	3	(GLASS SUN-RF)			
67-056A		COVER, HOLE			
FD01-67-HD1	1				

5390 FLOOR ATTACHMENTS

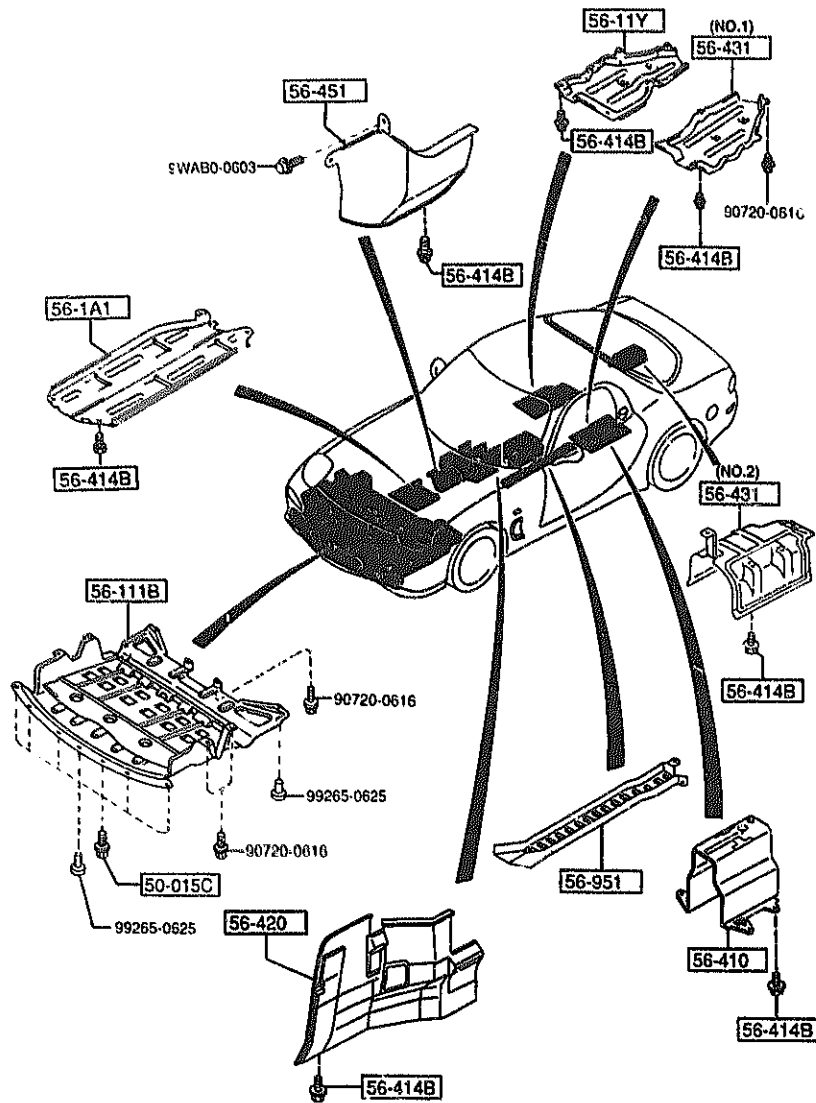

PART NO.	QTY	MODEL/RESTRICTION	MODEL/RESTRICTION	MODEL/RESTRICTION	FROM-TO
50-015C		BOLT			
BR70-50-022	6				
56-1A1		COVER, T/MISSION			
FD01-56-1A1C	1	(MT)			
56-11Y		COVER, UNDER-REAR			
FD01-56-113A	1				
56-111B		COVER, UNDER-FRONT			
FD01-56-100B	1				
56-410		INSULATOR, HEAT-FRONT			
FD01-56-430C	1				
56-414B		BOLT, INSULATOR, FRT H			
FB01-56-414	24	EAT (AT)			
FB01-56-414	29	(MT)			
56-420		INSULATOR, FRONT			
FD01-56-420C	1				
56-431		INSULATOR, HEAT			
FD01-56-114A	1	(ILLUST. NO. 1)			
FD01-56-450	1	(ILLUST. NO. 2)			
56-451		INSULATOR			
FD01-56-411	1				
56-951		PROTECTOR			
FD01-56-181	1				

5500 DASHBOARD EQUIPMENTS

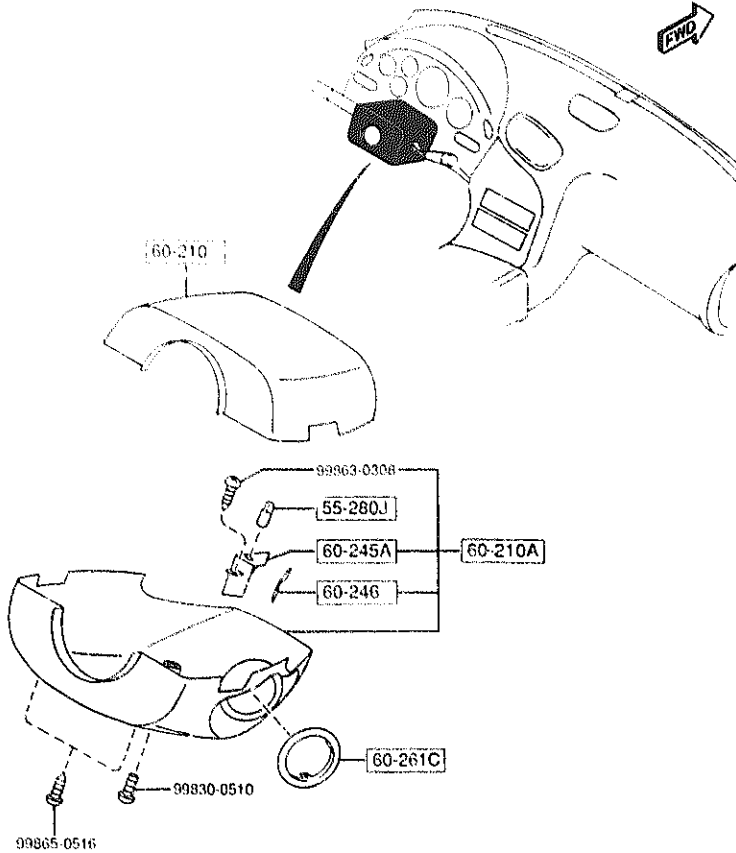

PART NO.	QTY	MODEL/RESTRICTION	MODEL/RESTRICTION	MODEL/RESTRICTION	FROM TO
55-280J		BULB			
B456-60-223	1				
60-210		COVER,COLUMN-UPPER			
FD01-60-221C	1				
00	INT-	FE5 FE6 FE7 BLACK			
60-210A		COVER,COLUMN-LOWER			
FD01-60-230D	1				
00	INT-	FE5 FE6 FE7 BLACK			
60-245A		CASE,LAMP			
FD01-60-245A	1				
60-246		LENS,COLUMN COVER			
FD01-60-246	1				
60-261C		RING SET-KEY CYLINDER			
LA01-60-261	1				

5520 -1 * METER HOOD

5520 METER HOOD

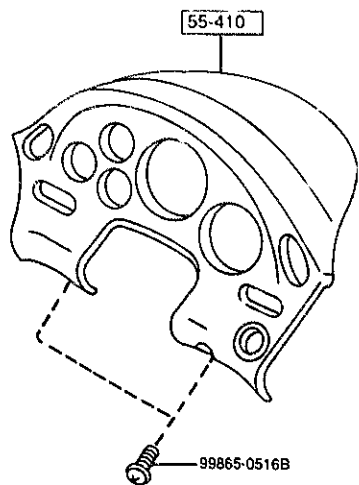
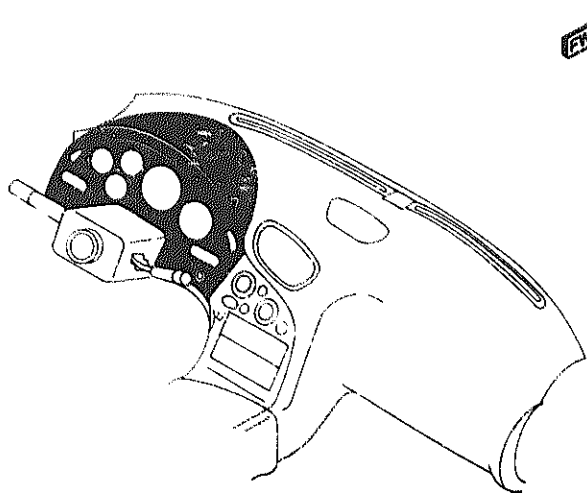

PART NO.	QTY	MODEL/RESTRICTION	MODEL/RESTRICTION	MODEL/RESTRICTION	FROM-TO
55-410		HOOD, METER			
FD15-55-420	1				

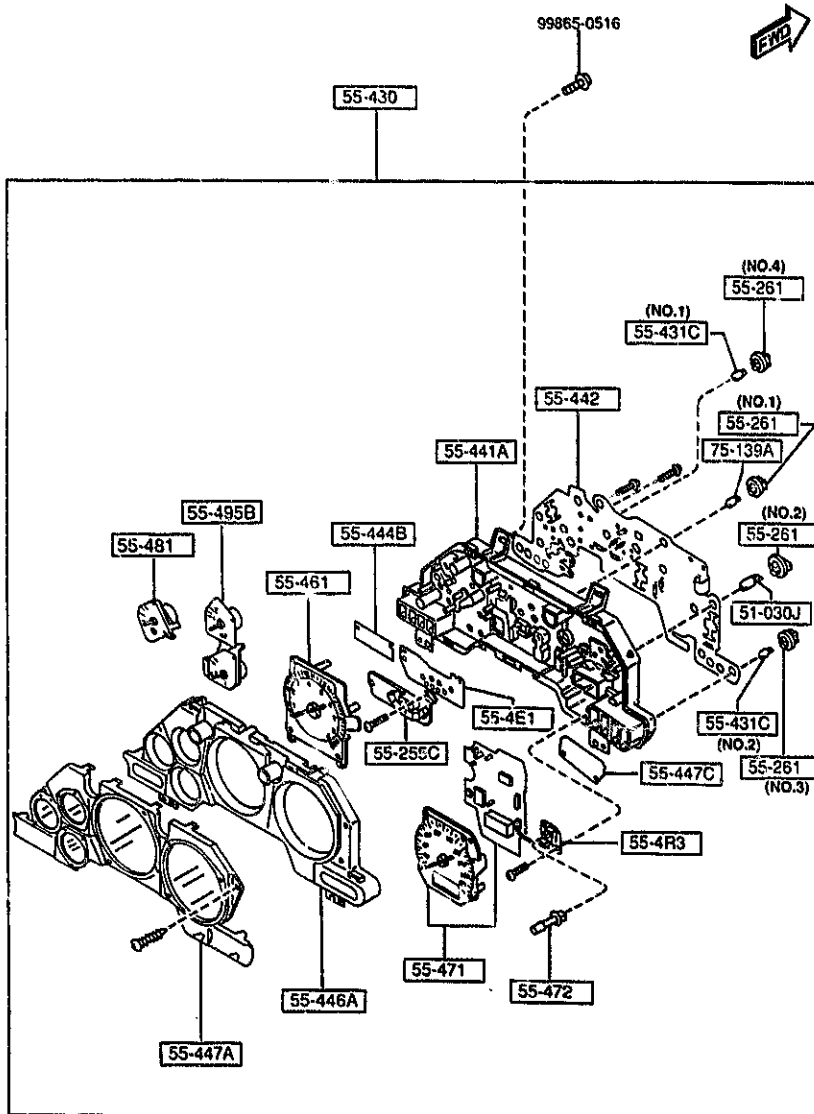

PART NO.	QTY	MODEL/RESTRICTION	MODEL/RESTRICTION	MODEL/RESTRICTION	FROM-TO
51-030J		BULB			
99701-6030	4	12V 3.4W			
55-255C		CASE, WARNING UNIT			
FD01-55-4W1	1	((MT))>(NOR. SUSP)			
FD02-55-4W1	1	(AT)			
55-261		SOCKET			
B456-55-261	6	12V 3W (ILLUST. NO.1)			
FD01-55-261	4	(ILLUST. NO.2)			
FD02-55-261	7	(ILLUST. NO.3)			
FD03-55-261	2	(ILLUST. NO.4)			
55-4E1		INDICATOR, ECONOMY-METER			
FD02-55-4E1	1	(AT)			
55-4R3		SWITCH			
FD01-55-487	1				
55-430		METER SET			
FD15-55-430C	1	((MT))>(NOR. SUSP)			
FD16-55-430C	1	((MT))>(HARD SUSP)			
FD17-55-430C	1	(AT)			
55-431C		BULB*B*, WARNING UNIT			
FD01-55-431	2	14V/2W (ILLUST. NO.1)			
FD02-55-431	7	14V/1.4W (ILLUST. NO.2)			
55-441A		CASE, METER			
FD01-55-441	1				
55-442		PLATE NO.1, PRINT			
FD01-55-442	1	((MT))>(NOR. SUSP)			
FD02-55-442	1	(AT)			
FD03-55-442	1	((MT))>(HARD SUSP)			

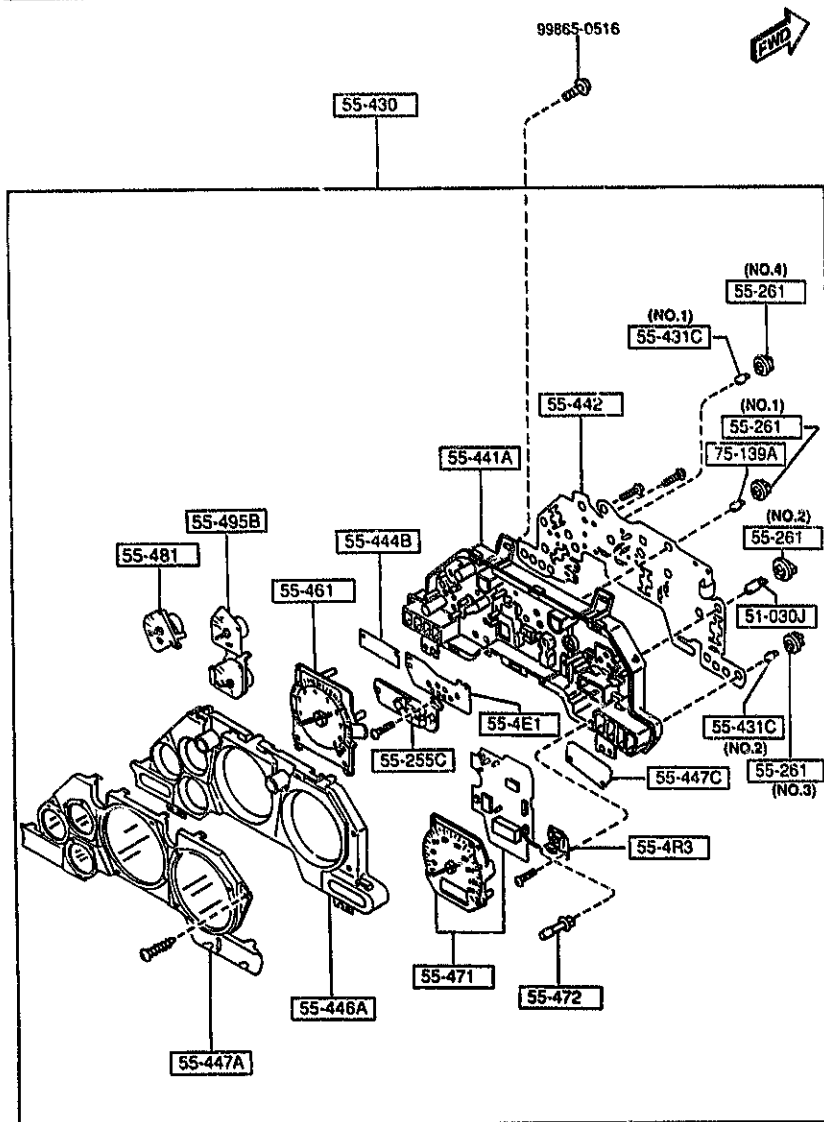

PART NO.	QTY	MODEL/RESTRICTION	MODEL/RESTRICTION	MODEL/RESTRICTION	FROM-TO
55-444B		LENS, WARNING			
FD01-55-444	1				
55-446A		PLATE, WINDOW			
FD01-55-446	1				
55-447A		GLASS, FRONT-WARNING UNIT			
FD01-55-447A	1				
55-447C		LENS, WARNING			
FD01-55-445	1				
55-461		TACHOMETER			
FD15-55-461A	1	((MT))>((NOR. SUSP))			
FD16-55-461A	1	((MT))>((HARD SUSP))			
FD17-55-461A	1	(AT)			
55-471		SPEEDOMETER			
FD15-55-471	1	(MT)			
FD17-55-471	1	(AT)			
55-472		KNOB, TRIPMETER			
FD01-55-473	1				
55-481		METER, FUEL			
FD01-55-481	1				
55-495B		METER, TEMP. -OIL			
FD01-55-491	1				
75-139A		BULB			
B456-55-431	6	12V 3W			

5560 DASHBOARD & RELATED PARTS

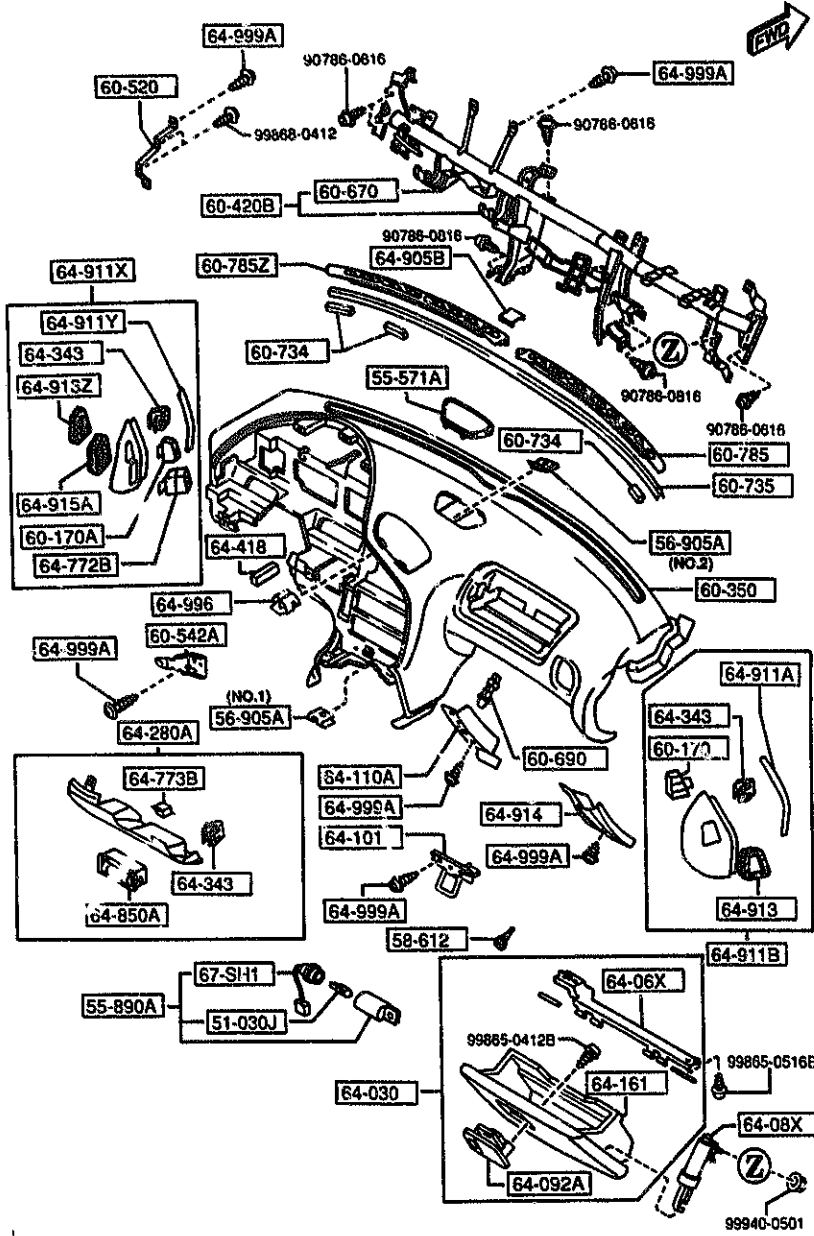

PART NO	QTY	MODEL/RESTRICTION	MODEL/RESTRICTION	MODEL/RESTRICTION	FROM-TO
51-030J		BULB			
3625-75-139	1	12V 1.4W, FOR WARNING			
55-571A		GRILLE, SPEAKER			
FD01-55-530A	1				
00	INT-	FE5 FE6 FE7 BLACK			
55-898A		LAMP, GLOVE BOX			
FD15-64-170A	1				
56-905A		NUT, SPRING			
B092-60-408	8	(ILLUST. NO.1)			
E016-60-408	3	(ILLUST. NO.2)			
58-612		CUSHION, RUBBER			
B092-64-046	2				
60-170		NOZZLE(R), SIDE-DEMIS TER			
FD01-60-182	1				
60-170A		NOZZLE(L), SIDE-DEMIS TER			
FD01-60-192	1				
60-350		PAD, CRASH			-3A06
FD15-60-350C	1				
02	INT-	FE5 FE6 FE7 BLACK			3A06-
FD15-60-350D	1				
02	INT-	FE5 FE6 FE7 BLACK			
60-420B		MEMBER, CRASH PAD			-3A06
FD15-60-420E A (FD15-60-420G)	1				
FD15-60-420G	1				3A06-
60-520		BRACKET, CENTER			
FD01-60-534	1				
60-542A		BRACKET, CENTER PANEL			
FD01-60-582	1				
3A06 FD333X-3D0939					

5560 DASHBOARD & RELATED PARTS

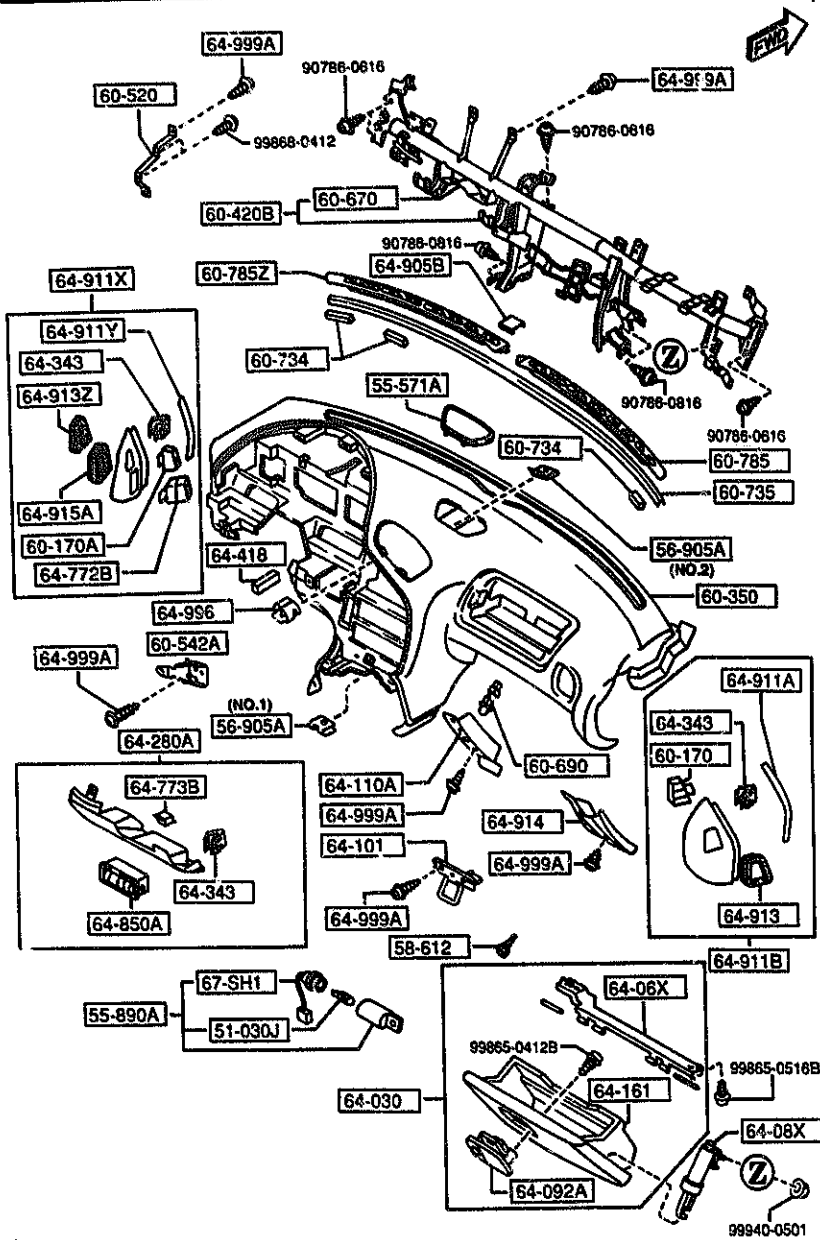

PART NO.	QTY	MODEL/RESTRICTION	MODEL/RESTRICTION	MODEL/RESTRICTION	FROM-TO
60-670		BRACKET, STEERING			
FD01-60-670	1				
60-690		SWITCH, GLOVE TRAY			
J002-66-540A	1				
60-734		PAD NO. 1, GARNISH-UPPER			
FD01-60-734A	3				
60-735		PAD NO. 2, GARNISH-UPPER			
FD01-60-735	1				
60-785		GRILLE(R), DEF. NOZZLE			
FD01-60-780	1				
02	INT-	FE5 FE6 FE7 BLACK			
60-785Z		GRILLE(L), DEF. NOZZLE			
FD01-60-790	1				
02	INT-	FE5 FE6 FE7 BLACK			
64-030		BOX, GLOVE			-3908
FD15-64-030D	1				
02	INT-	FE5 FE6 FE7 BLACK			
FD15-64-030E	1				3908-
02	INT-	FE5 FE6 FE7 BLACK			
64-06X		HINGE, GLOVE LID			
FD15-64-071A	1				
64-08X		DAMPER, GLOVE BOX			
FD15-64-08XA (FD15-44-08XB)	1				-3C14
FD15-64-08XB	1				3C14-
64-092A		LOCK, GLOVE LID			
BC1D-64-090	1				-3908
02	INT-	FE5 FE6 FE7 BLACK			
BC5E-64-090	1				3908-4520
00	INT-	FE5 FE6 FE7 BLACK			
3908 FD333*-300473 3C14 FD333*-301599 4520 FD333*-303548					

5570 CONSOLE

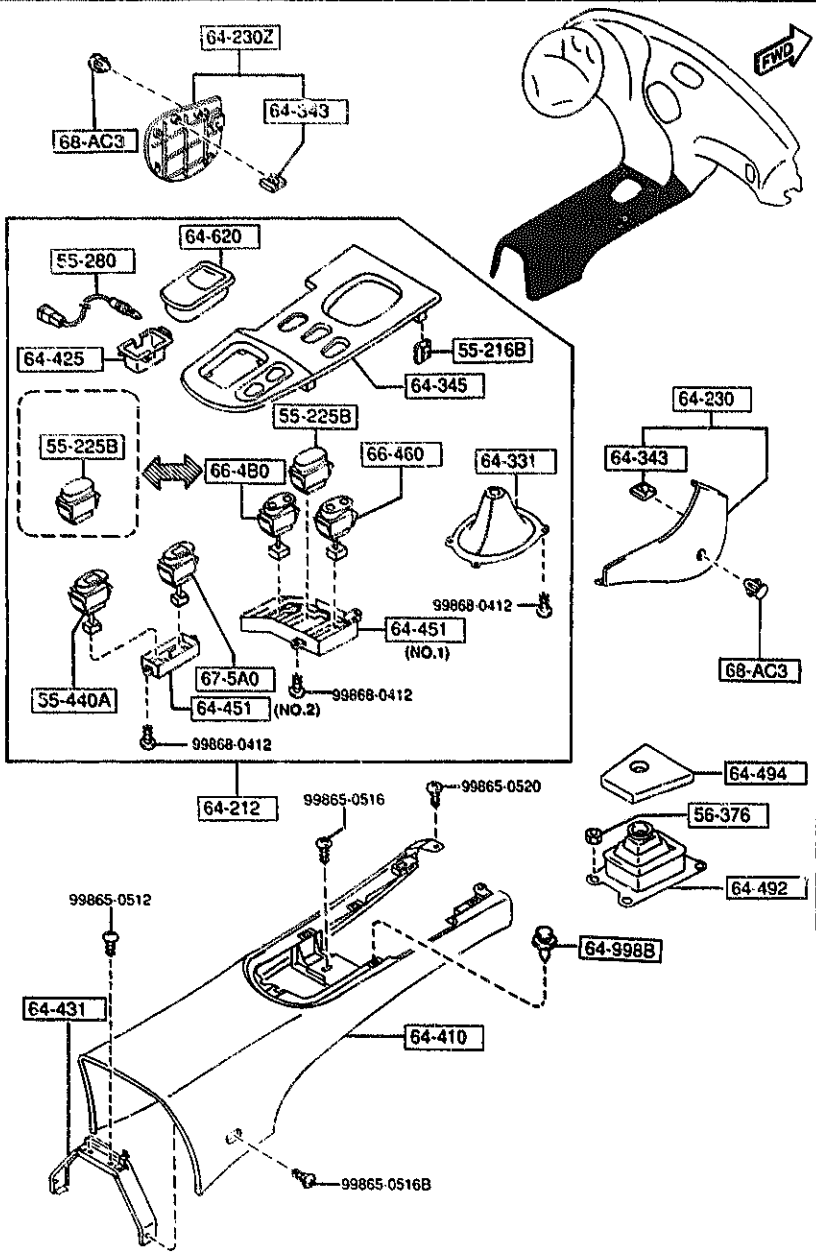

PART NO.	QTY	MODEL/RESTRICTION	MODEL/RESTRICTION	MODEL/RESTRICTION	FROM-TO
55-216B		SPRING,CENTER PANEL			
B092-55-257	5				
55-225B		COVER,HOLE			
FD01-55-225A	2				
00	INT-	FE5 FE6 FE7 BLACK			
55-280		BULB & SOCKET			
FD01-55-280	1				
55-440A		WARNING,HEAT			
FD01-67-5H0C	1				
56-376		NUT,SELF LOCK			
B001-56-376	4 (MT)				
64-212		PANEL,CONSOLE			
FD15-64-470	1	((MT)>>(W/O SUN-RF)) ((MT)>>(STEEL SUN-RF))			
00	INT-	FE5 FE6 FE7 BLACK FE5 FE6 FE7 BLACK			
FD17-64-470	1	((AT)>>(W/O SUN-RF))			
00	INT-	FE5 FE6 FE7 BLACK			
FD18-64-470	1	((MT)>>(GLASS SUN-RF))			
00	INT-	FE5 FE6 FE7 BLACK			
FD19-64-470	1	((AT)>>(GLASS SUN-RF))			
00	INT-	FE5 FE6 FE7 BLACK			
64-230		WALL(R),SIDE			
FD15-64-220A	1				
02	INT-	FE5 FE6 FE7 BLACK			
64-230Z		WALL(L),SIDE			
FD01-64-240A	1				
02	INT-	FE5 FE6 FE7 BLACK			
64-331		BOOT,CHANGE			
FD01-64-330C	1 (MT)				

AUFA05

CAT. AUFA05-03

1995-03

2-K15

5570 CONSOLE

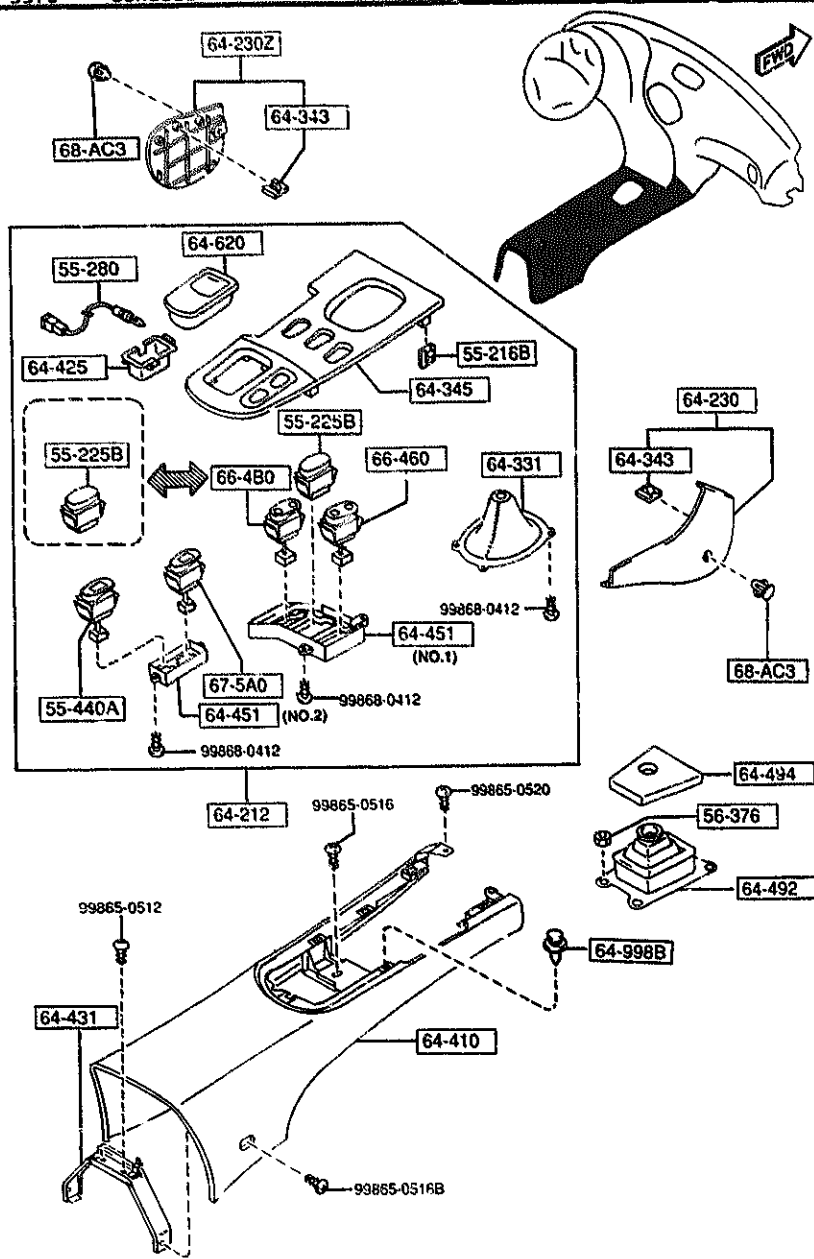

5570 -2 CONSOLE

PART NO.	QTY	MODEL/RESTRICTION	MODEL/RESTRICTION	MODEL/RESTRICTION	FROM-TO
CONT'D					
00	INT-	FE5 FE6 FE7 BLACK			
64-343		SPRING			
H260-64-343	3				
64-345		PANEL, SWITCH			
FD15-64-471	1 (MT)				
FD17-64-471	1 (AT)				
64-410		CONSOLE, REAR			
FD01-64-420E	1				
02	INT-	FE5 FE6 FE7 BLACK			
64-42F		CASE, LAMP			
FD01-64-42FA	1				
64-431		BRACKET, RR. CONSOLE-N 0.1			
FD15-64-43XA	1				
64-451		PANEL, SWITCH			
FD01-66-468	1 (ILLUST. NO.1)				
FD02-66-468	1 (ILLUST. NO.2)				
64-492		INSULATOR, BOOT			
FD01-64-490 A (FD01-64-490A)	1				-3817
FD01-64-490A	1 (MT)				3817-
64-494		PAD, CHANGE BOOT			
FB01-64-495	1 (MT)				
64-620		TRAY, ASH			
FD01-64-610A	1				
00	INT-	FE5 FE6 FE7 BLACK			
64-998B		CLIP			
FD01-64-998	1				-3A01
66-480		SWITCH, FOG-FRONT			
FD01-66-480A	1 (GLASS SUN-RF)				
3817 FD333*-300847					
3A01 FD333*-300888					

AUFA05

CAT. AUFA05-03

1995-03

5570 CONSOLE

5570 -3 * CONSOLE

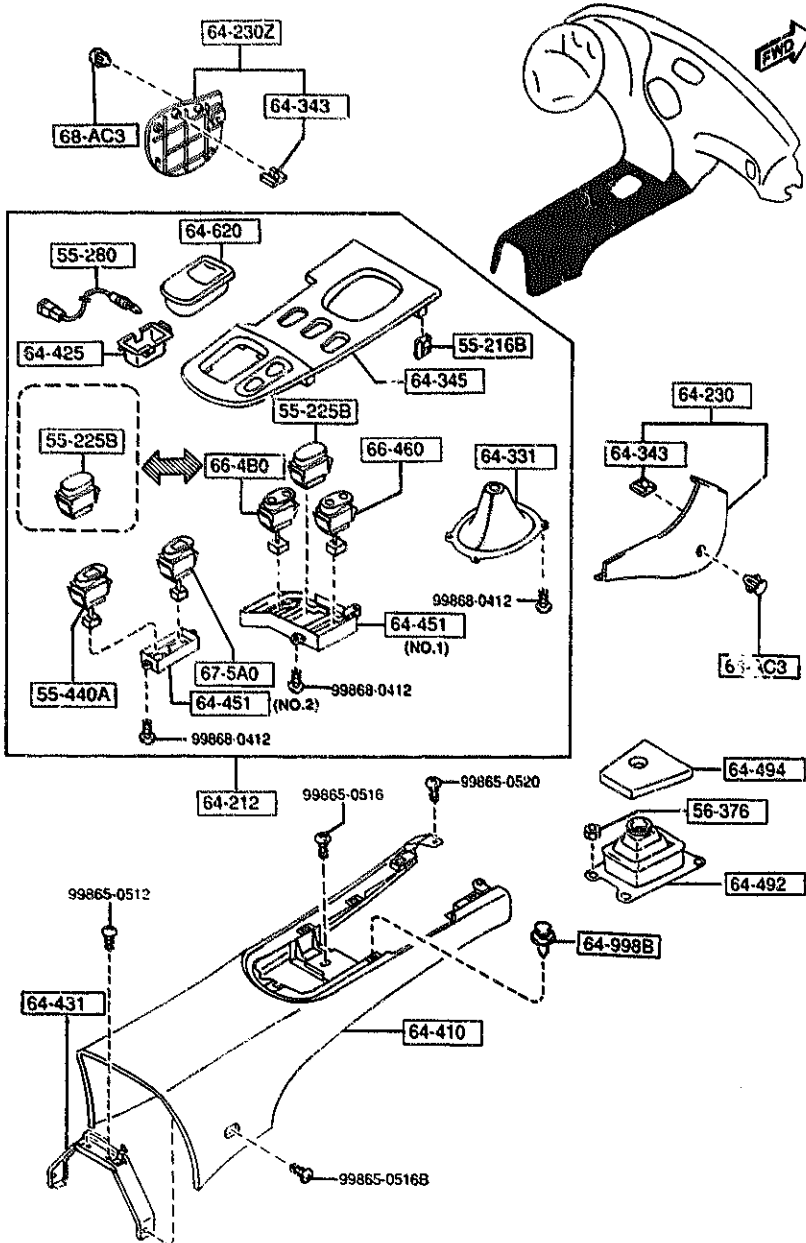

PART NO.	QTY	MODEL/RESTRICTION	MODEL/RFSTRICTION	MODEL/RESTRICTION	FROM-TO
66-460		SWITCH,RR. DEF.			
FD01-66-460A	1				
67-5A0		DISPLAY, SECURITY-ALARM			
FD01-67-5A0C	1				
68-AC3		FASTENER			
B467-68-AC3	2				
02	INT-	FE5 FE6 FE7 BLACK			



AUFA05

CAT. AUFA05-03

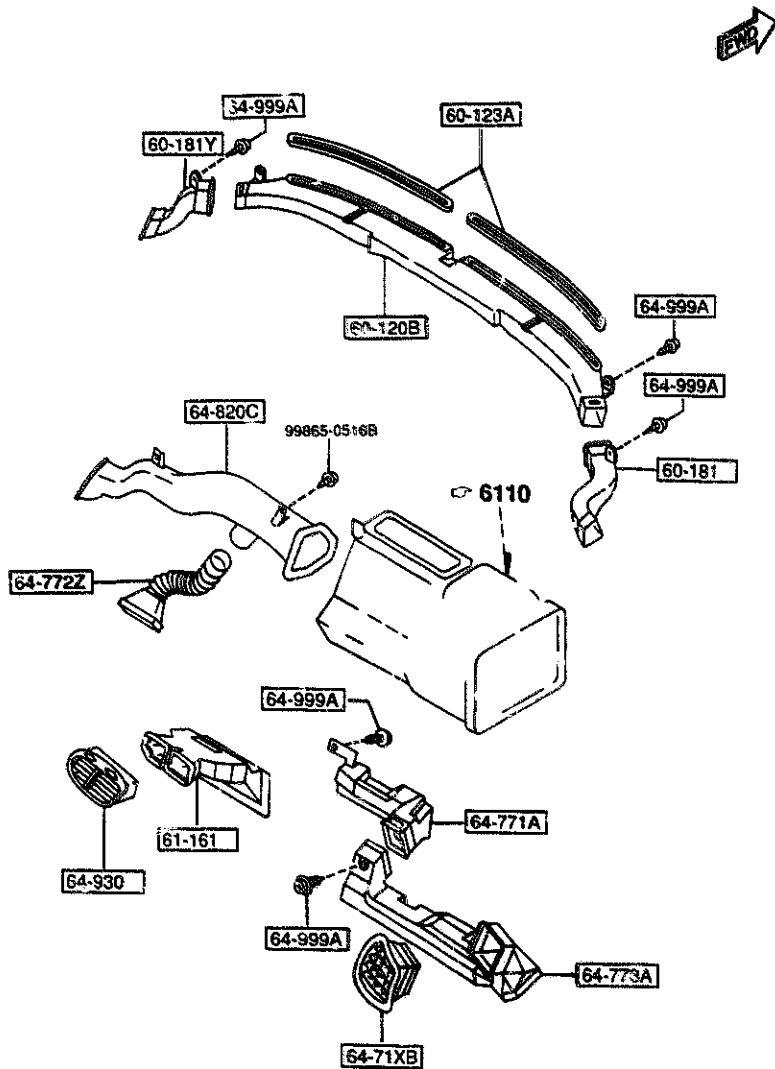
1995-03

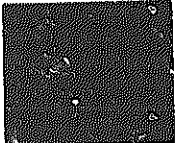
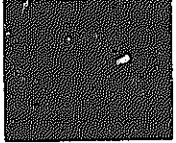

PART NO.	QTY	MODEL/RESTRICTION	MODEL/RESTRICTION	MODEL/RESTRICTION	FORM-F3
60-120B		NOZZLE, DEFROSTER			
FD01-60-120	1				
60-123A		TAPE, SOFT-DEF. NOZZLE			
FD01-60-123	2				
60-181		HOSE, SIDE-DEMISTER			
FD01-60-181	1				
60-181Y		DUCT(L), SIDE DEMIST.			
FD01-60-191	1				
61-161		DUCT, CENTER			
FD01-61-160B	1				
64-71XB		LOUVER(R), VENT. GRILLE			
FD15-64-81XA	1				
02	INT-	FE5 FE6 FE7 BLACK			
61-771A		DUCT NO.1(R)			
FD15-64-741	1				
64-772Z		DUCT(L), LAP			
FD01-64-772B	1				
64-773A		DUCT NO.3(R)			
FD15-64-743B	1				
64-820C		DUCT(L), VENTILATOR			
FD01-64-84XA	1				
64-930		GRILLE(C), VENTILATOR			
FD01-64-930A	1				
02	INT-	FE5 FE6 FE7 BLACK			
64-999A		SCREW, TAPPING			
W201-64-999	6				

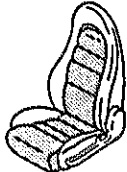
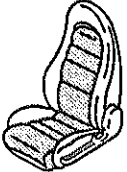
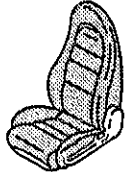
SPECIFICATIONS	GRADE	BASE	R2	BASE-OPT-RKG, TOURING
	SEAT TYPES	STA TYPE	STC TYPE	STD TYPE
SEAT TRIM	CLOTH "A"			
				

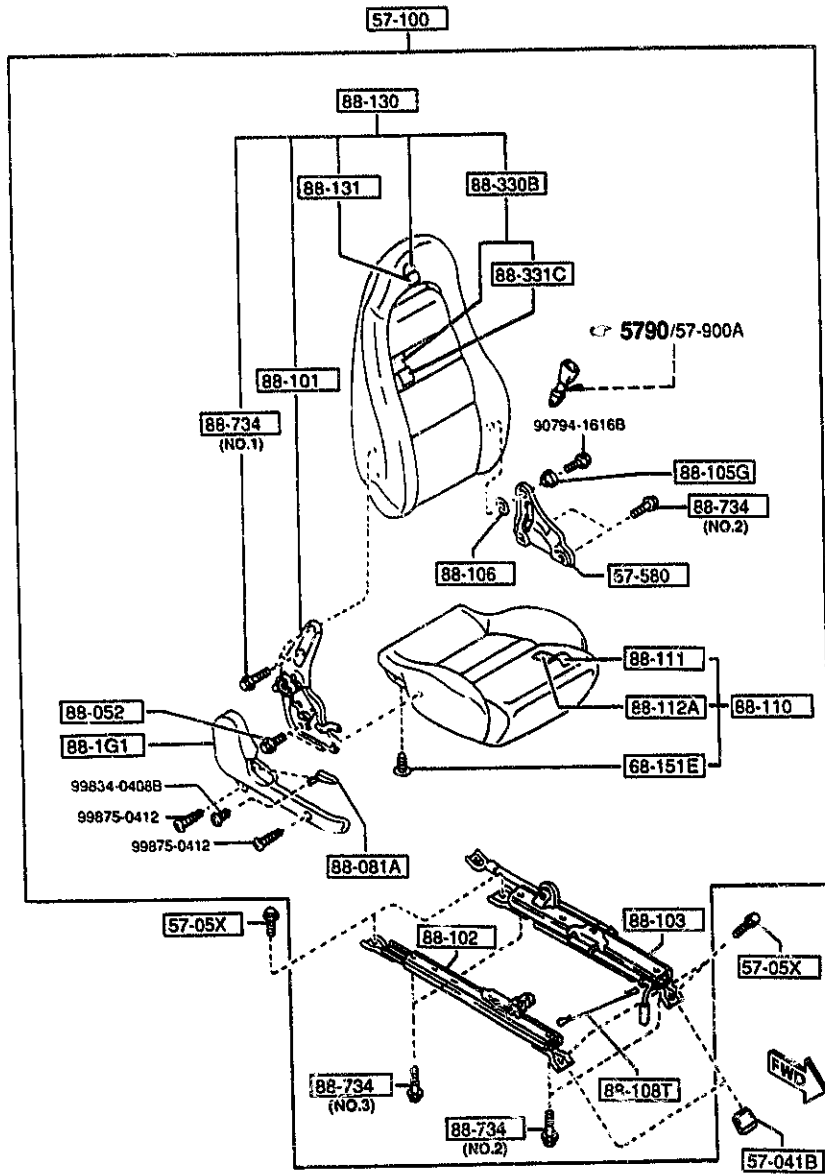

AUFA05

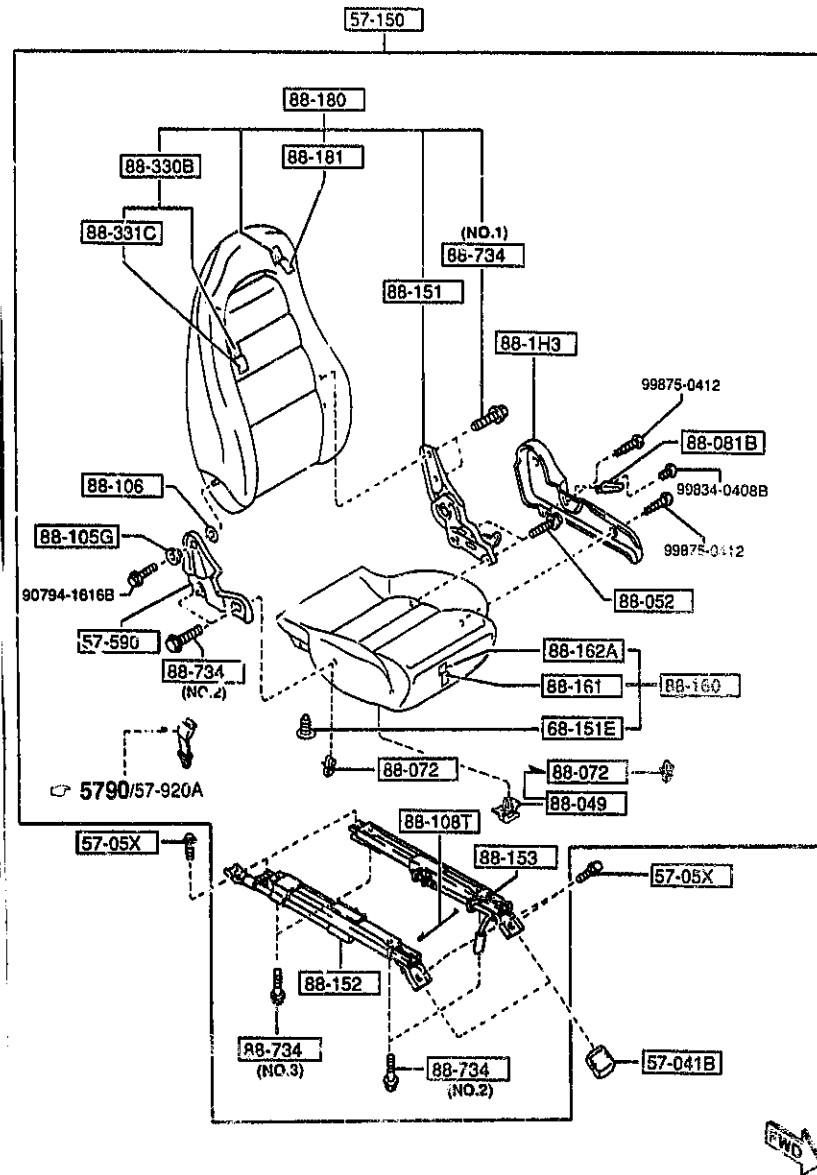

AUFA05

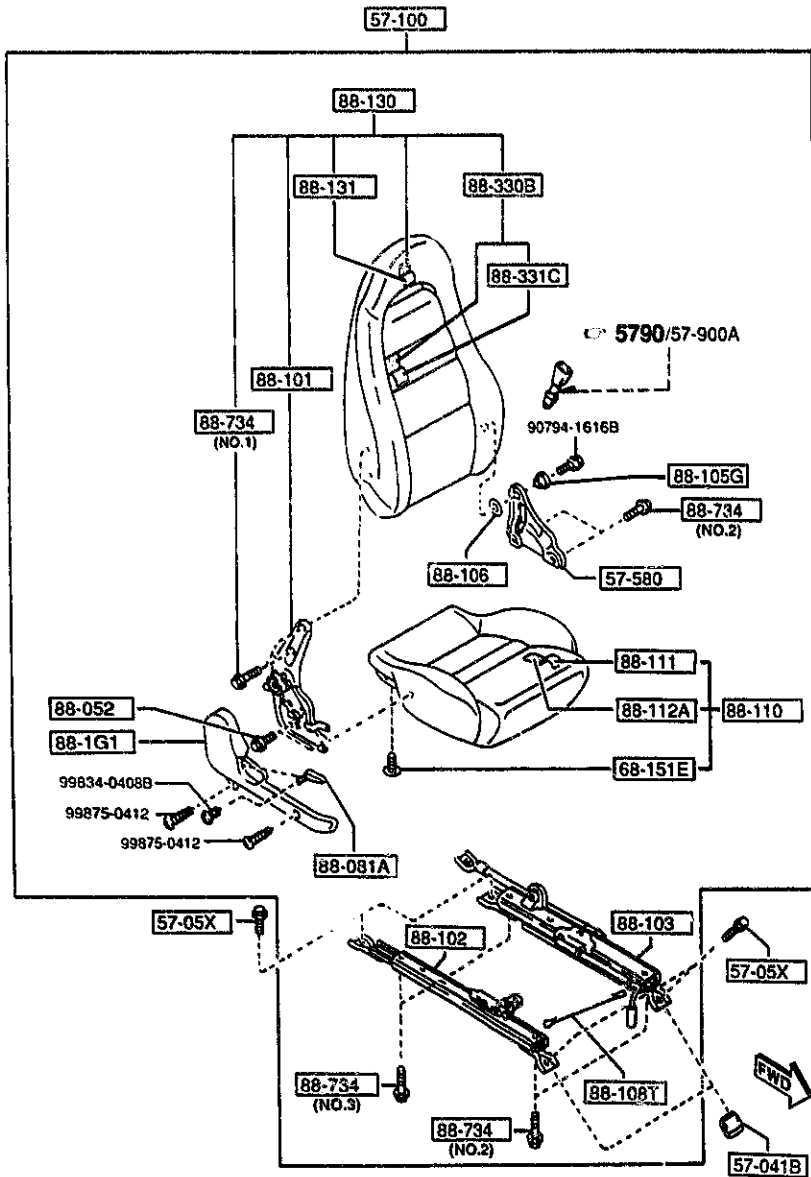

PART NO.	QTY	MODEL/RESTRICTION	MODEL/RESTRICTION	MODEL/RESTRICTION	FROM-TO
57-041B		COVER NO.1,ADJ-FRT			
J001-57-041	4				
02	INT-	FE5 BLACK			
17	INT-	FE7 RED			
33	INT-	FE6 TAN			
57-05X		BOLT, LINK			
8455-57-05XA	8				
57-100		SEAT(R),FRONT			
FD15-57-100	1	BASE, (STA TYPE)			
02	INT-	FE5 BLACK			
FD18-57-100	1	BASE-OPT-PKG, TOURIN G, (STD TYPE)			
02	INT-	FE5 BLACK			-3818
17	INT-	FE7 RED			3818-
18	INT-	FE7 RED			-3818
33	INT-	FE6 TAN			3818-
34	INT-	FE6 TAN			
FD19-57-100	1	R2, (STC TYPE)			
02	INT-	FE5 BLACK			
57-150		SEAT(L),FRONT			
FD01-57-150C	1	BASE, (STA TYPE)			
02	INT-	FE5 BLACK			
FD03-57-150C	1	R2, (STC TYPE)			
02	INT-	FE5 BLACK			
FD05-57-150C	1	BASE-OPT-PKG, TOURIN G, (STD TYPE)			-3C01
02	INT-	FE5 BLACK			-3818
17	INT-	FE7 RED			3818-
18	INT-	FE7 RED			-3818
33	INT-	FE6 TAN			3818-
34	INT-	FE6 TAN			
3818 FD323*-300084					
3C01 FD333*-301464					

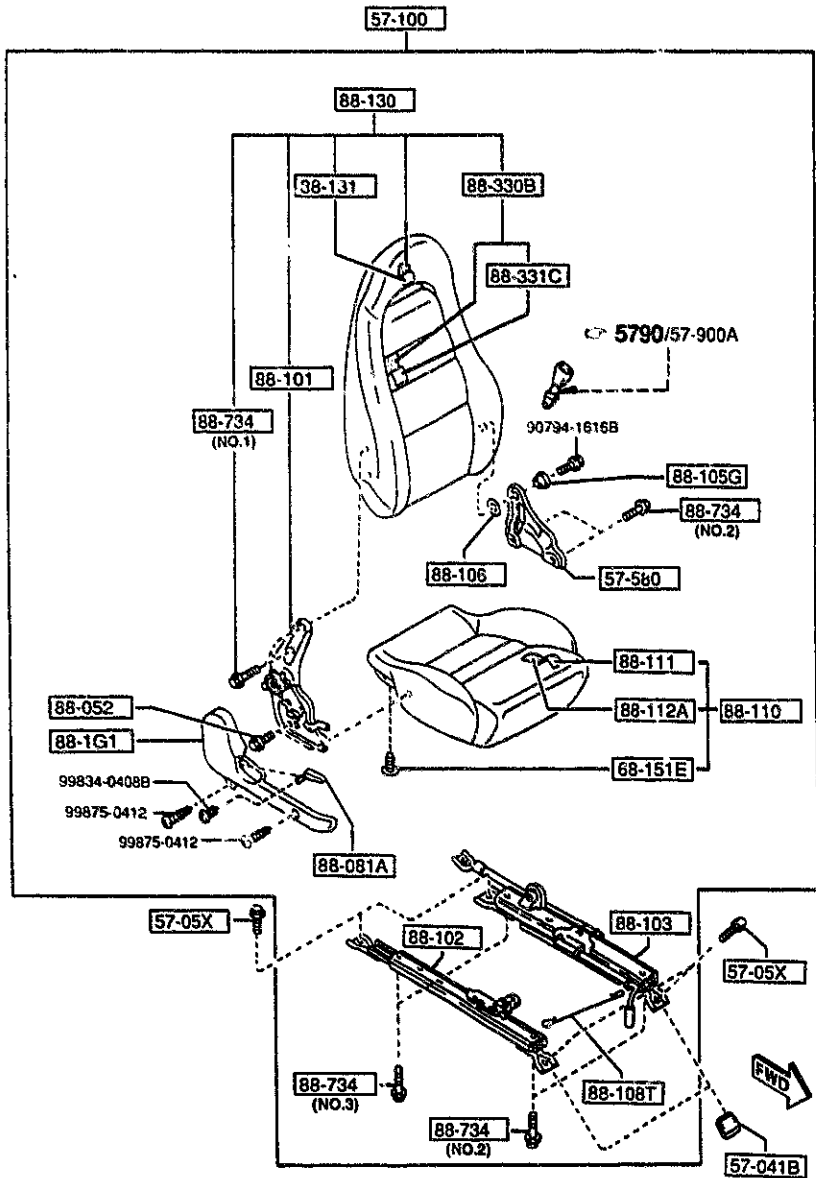

PART NO	QTY	MODEL/RESTRICTION	MODEL/RESTRICTION	MODEL/RESTRICTION	FRONT-YG
88-101		COVER NO.1, SIDE-F. SEAT			
FD01-88-101	1				
02	INT-	FE5 BLACK			
17	INT-	FE7 RED			
33	INT-	FE6 TAN			
88-1H3		COVER NO.4, SIDE-F. SEAT			
FD01-88-1H3	1				
02	INT-	FE5 BLACK			
17	INT-	FE7 RED			
33	INT-	FE6 TAN			
88-101		KNUCKLE(R), RECLINING			
FD01-88-101	1				
88-102		ADJUSTER, NO.1			
FD01-88-102	1				
88-103		ADJUSTER, NO.2			
FD11-88-103	1				
88-105G		BUSH, HINGE			
FD01-88-005	2				
88-106		WASHER			
FD01-88-006	2				
88-108T		WIRE, RELEASE			
FD01-88-106	2				
88-110		CUSHION(R), FRT SEAT			
FD15-88-110	1	BASE, (STA TYPE)			
02	INT-	FE5 BLACK			
FD18-88-110	1	BASE-OPT-PKG, TOURING (STD TYPE)			
02	INT-	FE5 BLACK			
17	INT-	FE7 RED			
18	INT-	FE7 RED			
3818 FD333*-300084					
					-3818 3818-

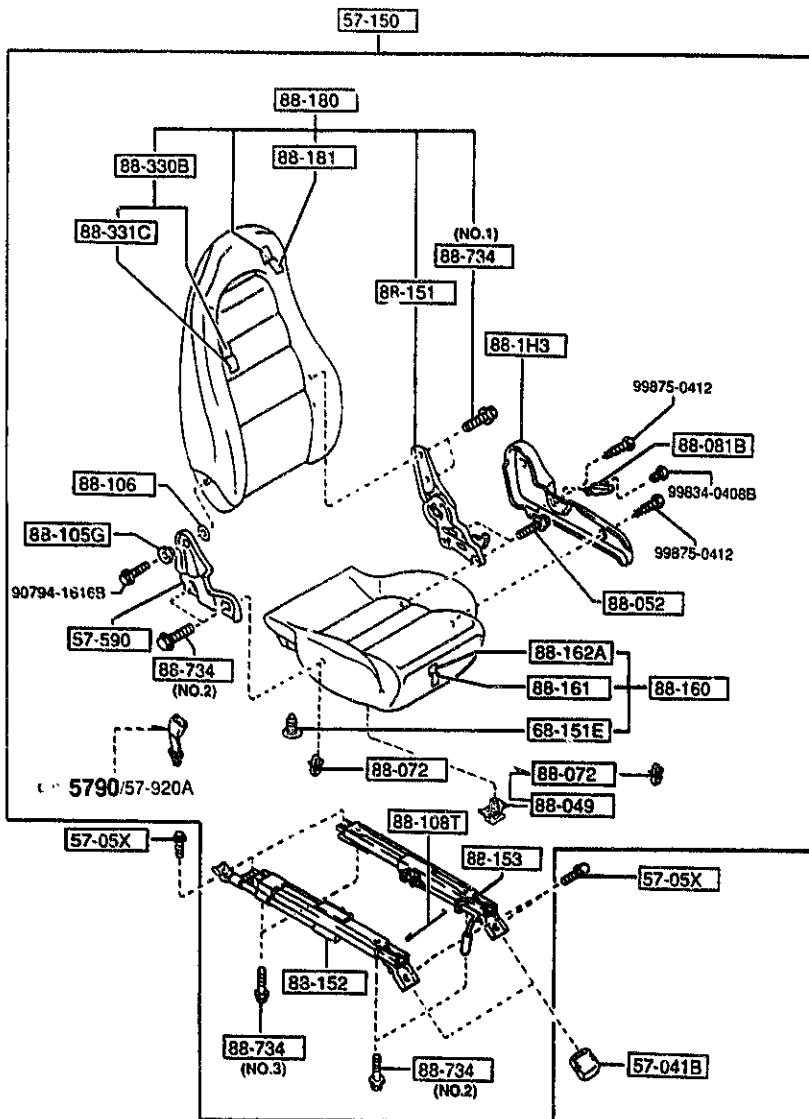

PART NO.	QTY	MODEL/RESTRICTION	MODEL/RESTRICTION	MODEL/RESTRICTION	FROM-TO
CONT'D					
33	INT-	FE6 TAN			-3818
34	INT-	FE6 TAN			3818-
F110-88-110	1	R2, (STC TYPE)			
02	INT-	FE5 BLACK			
88-111		TRIM(R),SEAT CUSHION			
FD03-88-111	1	R2, (STC TYPE)			
02	INT-	FE5 BLACK			
FD15-88-111	1	BASE, (STA TYPE)			-4201
02	INT-	FE5 BLACK			
FD18-88-111	1	BASE-OPT-PKG, TOURIN G, (STD TYPE)			-4261
02	INT-	FE5 BLACK			
17	INT-	FE7 RED			-3818
18	INT-	FE7 RED			3818-
33	INT-	FE6 TAN			-3818
34	INT-	FE6 TAN			3818-
FD01-88-111	1	BASE, (STA TYPE)			4201-
02		BLACK			
FD05-88-111	1	BASE-OPT-PKG, TOURIN G, (STD TYPE)			4201-
02	INT-	FE5 BLACK			
88-112A		PAD(N),CUSHION-FRT			
FD15-88-112	1				
88-130		BACK(R),FRONT SEAT			
FD15-88-130	1	BASE, (STA TYPE)			
02	INT-	FE5 BLACK			
FD18-88-130	1	BASE-OPT-PKG, TOURIN G, (STD TYPE)			
02	INT-	FE5 BLACK			
17	INT-	FE7 RED			-3818
		3818 FD333*-300084			
		4201 FD333*-302262			



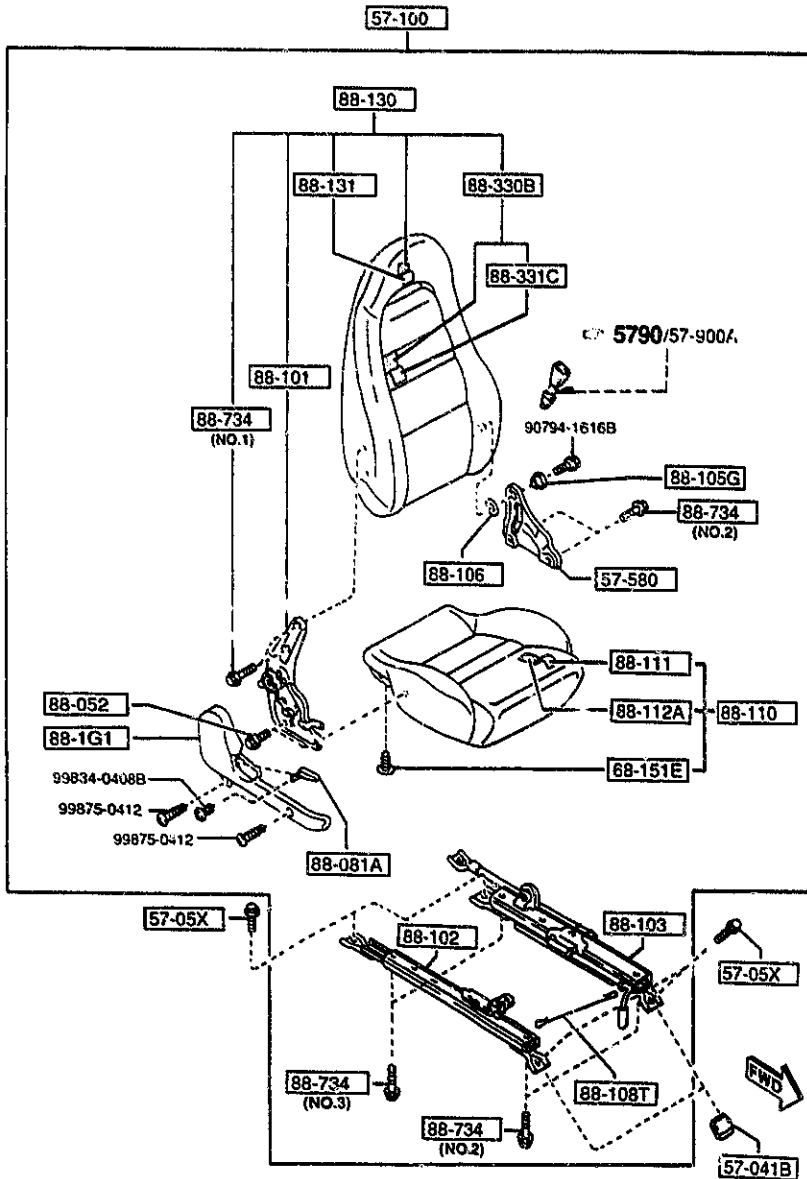

PART NO.	QTY	MODEL/RESTRICTION	MODEL/RESTRICTION	MODEL/RESTRICTION	FROM-TO
CUNT'D					
18	INT-	FE7 RED			3818-
33	INT-	FE6 TAN			-3818
34	INT-	FE6 TAN			3818-
FD19-88-130	1	R2, (STC TYPE)			
02	INT-	FES BLACK			
88-131		TRIM(R), SEAT BACK			
FD15-88-131	1	BASE, (STA TYPE)			
02	INT-	FES BLACK			
FD18-88-131	1	BASE-OPT-PKG, TOURIN (STD TYPE)			
02	INT-	FES BLACK			
17	INT-	FE7 RED			-3818
18	INT-	FE7 RED			3818-
33	INT-	FE6 TAN			-3818
34	INT-	FE6 TAN			3818-
FD19-88-131	1	R2, (STC TYPE)			
02	INT-	FES BLACK			
88-151		KNUCKLE(L), RECLINING			
FD01-88-155	1				
88-152		ADJUSTER NO.3			
FD01-88-152	1				
88-153		ADJUSTER NO.4			
FD01-88-153	1				
88-160		CUSHION(L), FRT SEAT			
FD01-88-160	1	BASE, (STA TYPE)			
02	INT-	FES BLACK			
FD03-88-160	1	R2, (STC TYPE)			
02	INT-	FES BLACK			
FD05-88-160	1	BASE-OPT-PKG, TOURIN			
3818 FD333*-30084					

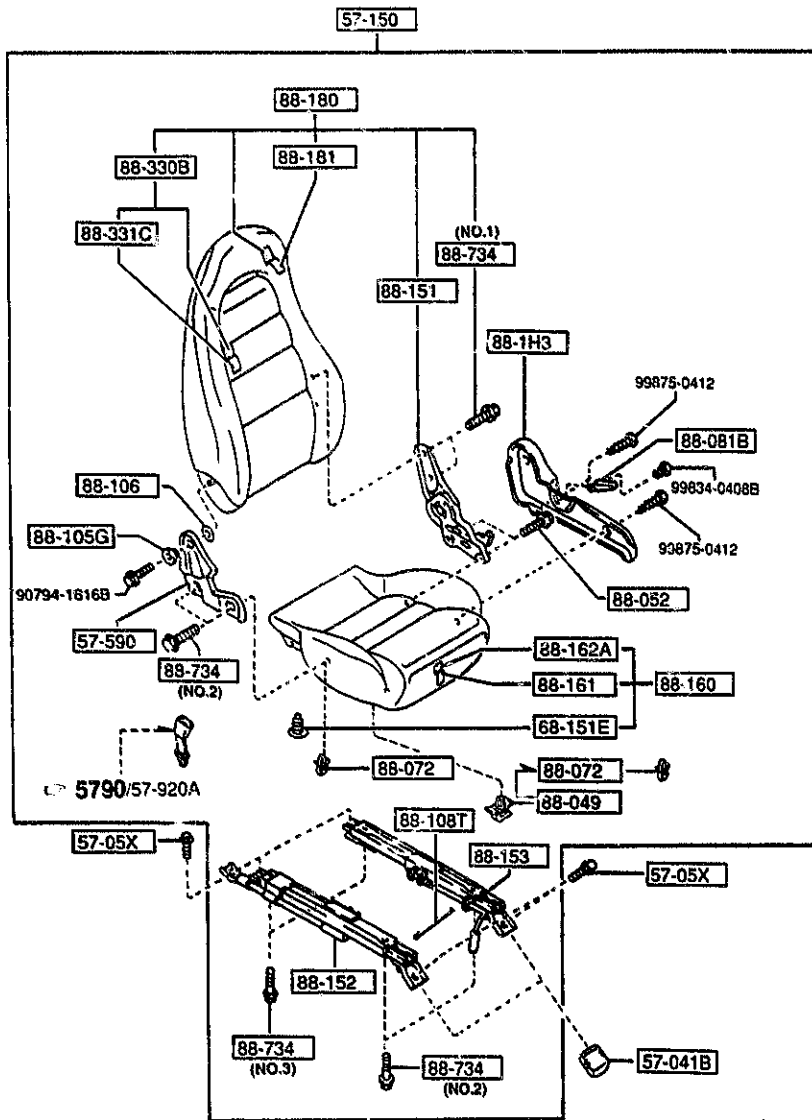

PART NO.	QTY	MODEL/RESTRICTION	MODEL/RESTRICTION	MODEL/RESTRICTION	FROM TO
CONT'D					
		G, (STD TYPE)			
02	INT-	FE5 BLACK			
17	INT-	FE7 RED			-3818
18	INT-	FE7 RED			3818-
33	INT-	FE6 TAN			-3818
34	INT-	FE6 TAN			3818-
		88-161 TRIM(L),SEAT CUSHION			
FD01-88-161	1	BASE, (STA TYPE)			
02	INT-	FE5 BLACK			
FD03-88-161	1	R2, (STC TYPE)			
02	INT-	FE5 BLACK			
FD05-88-161	1	BASE-OPT-PKG, TOURIN G, (STD TYPE)			
02	INT-	FE5 BLACK			
17	INT-	FE7 RED			-3818
18	INT-	FE7 RED			3818-
33	INT-	FE6 TAN			-3818
34	INT-	FE6 TAN			3818-
		88-162A PAD(L),CUSHION-FRT			
FD01-88-162	1				
		88-180 BACK(L),FRONT SEAT			
FD01-88-180	1	BASE, (STA TYPE)			
02	INT-	FE5 BLACK			
FD03-88-180	1	R2, (STC TYPE)			
02	INT-	FE5 BLACK			
FD05-88-180	1	BASE-OPT-PKG, TOURIN G, (STD TYPE)			
02	INT-	FE5 BLACK			
17	INT-	FE7 RED			-3818
18	INT-	FE7 RED			3818-
3818 FD333*-300084					

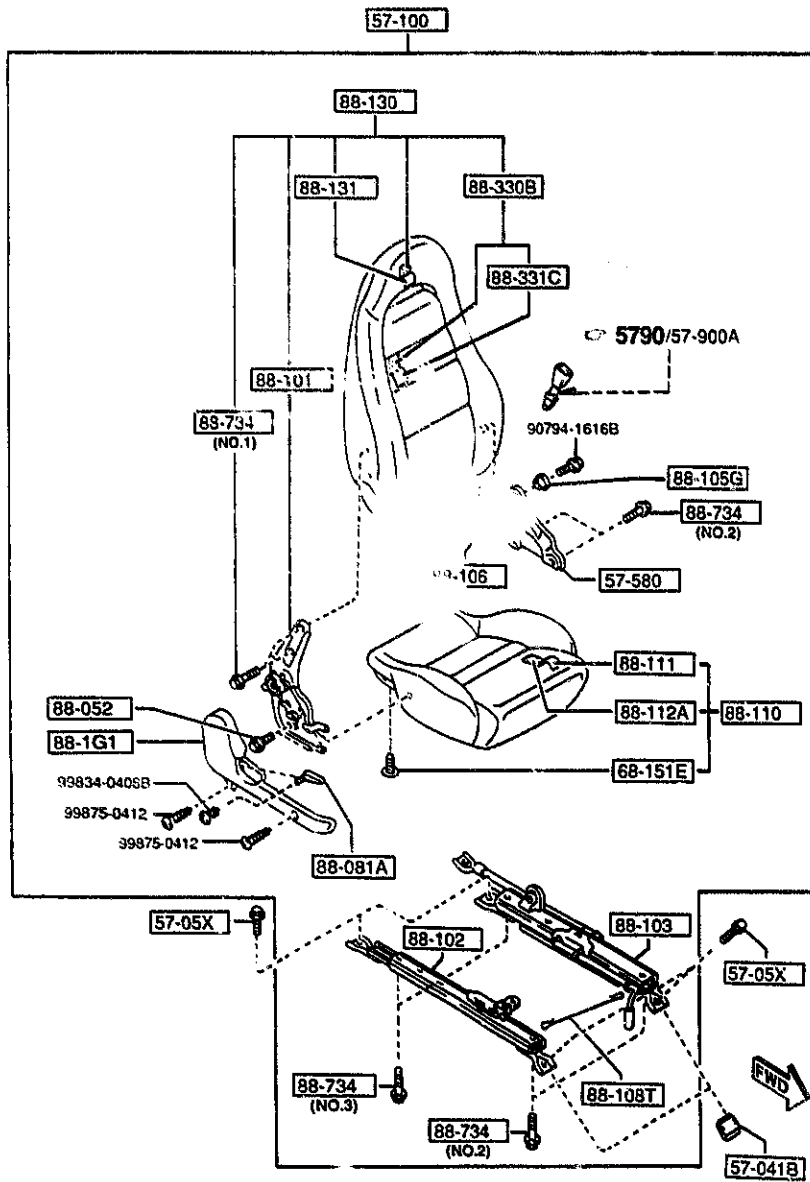

PART NO.	QTY	MODEL/RESTRICTION	MODEL/RESTRICTION	MODEL/RESTRICTION	FRM-10
CONT'D					
33	INT-	FE6 TAN			-3818
34	INT-	FE6 TAN			3818-
		↑ 88-181 ↓	TRIM(L), SEAT BACK		
FD01-88-181	1	BASE, (STA TYPE)			
02	INT-	FE5 BLACK			
FD03-88-181	1	R2, (STC TYPE)			
02	INT-	FE5 BLACK			
FD05-88-181	1	BASE-OPT-PKG, TOURIN G, (STD TYPE)			
02	INT-	FE5 BLACK			
17	INT-	FE7 RED			-3818
18	INT-	FE7 RED			3818-
33	INT-	FE6 TAN			-3818
34	INT-	FE6 TAN			3818-
		↑ 88-330B ↓	BACK(C), FRT SEAT		
FD01-88-6D0	2	BASE, (STA TYPE)			
02	INT-	FE5 BLACK			
FD03-88-6D0	2	R2, (STC TYPE)			
02	INT-	FE5 BLACK			
FD05-88-6D0	2	BASE-OPT-PKG, TOURIN G, (STD TYPE)			
02	INT-	FE5 BLACK			
17	INT-	FE7 RED			-3818
18	INT-	FE7 RED			3818-
33	INT-	FE6 TAN			-3818
34	INT-	FE6 TAN			3818-
		↑ 88-331C ↓	TRIM(C), FRT BACK		
FD01-88-6D2	2	BASE, (STA TYPE)			
02	INT-	FE5 BLACK			
FD03-88-6D2	2	R2, (STC TYPE)			
3818 FD333*-300084					

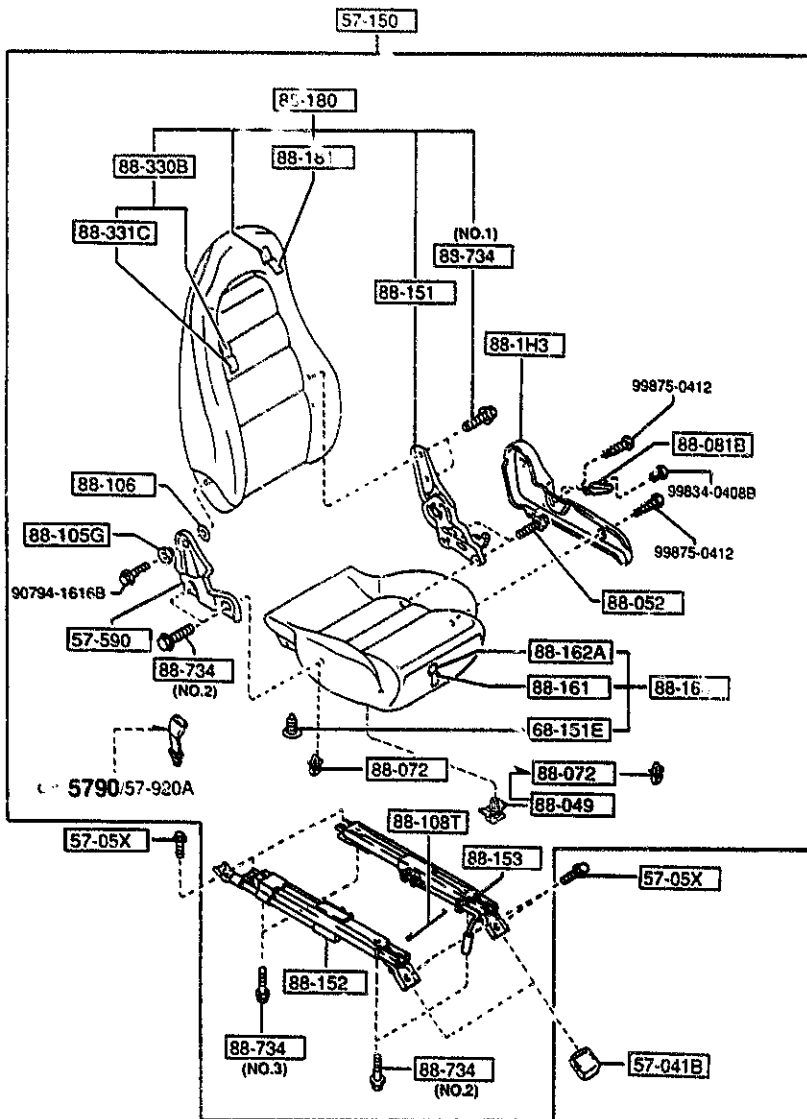

PART NO.	QTY	MODEL/RESTRICTION	MODEL/RESTRICTION	MODEL/RESTRICTION	FROM TO
CONT'D					
02	INT-	FES BLACK			
FD05-88-6D2	2	BASE-OPT-PKG, TOURIN G (STD TYPE)			
02	INT-	FES BLACK			
17	INT-	FE7 RED			-3818
18	INT-	FE7 RED			3818-
33	INT-	FE6 TAN			-3818
34	INT-	FE6 TAN			3818-
88-734		BOLT			
B456-88-815	4	(ILLUST. NO.1)			
B260-88-818	8	(ILLUST. NO.2)			
EA01-88-818	4	(ILLUST. NO.3)			
3818 FD333*-300084					

FWD

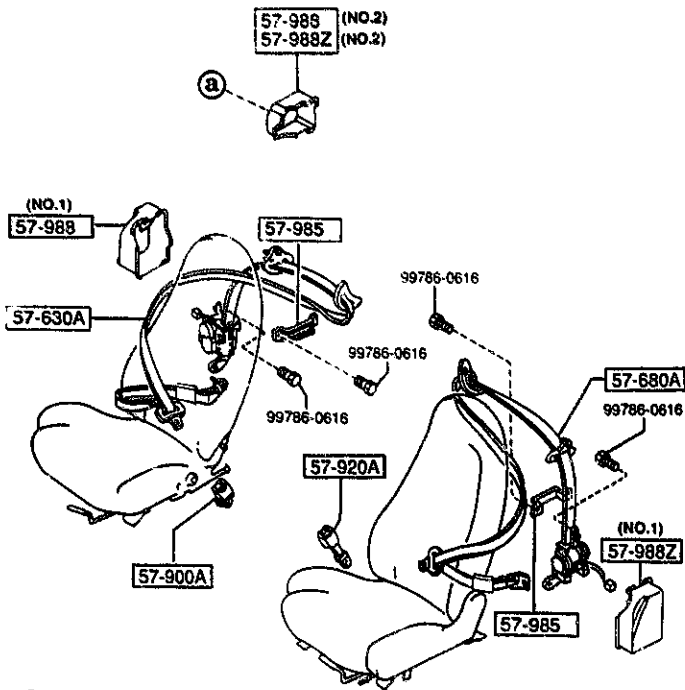
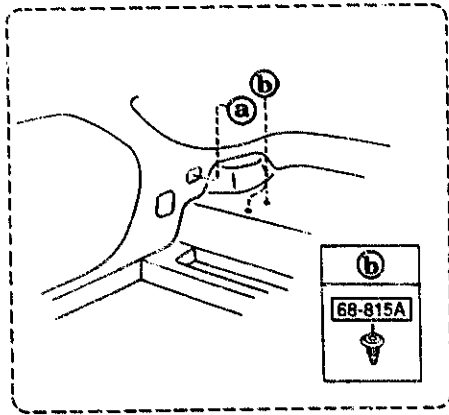

PART NO.	QTY	MODEL/RESTRICTION	MODEL/RESTRICTION	MODEL/RESTRICTION	FROM-TO
57-630A		BELT'B'(R),FRT SEAT			
FD15-57-630D	1				-3801
00	INT-	FE5 FE6 FE7 BLACK			
FD15-57-630E	1				3801-3824
00	INT-	FE5 FE6 FE7 BLACK			
FD15-57-630F	1				3824-
00	INT-	FE5 FE6 FE7 BLACK			
57-680A		BELT'B'(L),FRT SEAT			
FD15-57-690D	1				-3801
00	INT-	FE5 FE6 FE7 BLACK			
FD15-57-690E	1				3801-3824
00	INT-	FE5 FE6 FE7 BLACK			
FD15-57-690F	1				3824-
00	INT-	FE5 FE6 FE7 BLACK			
57-900A		BELT'A'(R),FRT SEAT			
F001-57-620B	1				
00	INT-	FE7 BLACK			
02	INT-	FE5 FE6 FE7 BLACK			
57-920A		BELT'A'(L),FRT SEAT			
F001-57-680D	1				
00	INT-	FE7 BLACK			
02	INT-	FE5 FE6 FE7 BLACK			
57-985		PLATE SET,SEAT BELT			
FD01-57-985A	2				
57-988		COVER(R),RETRACTOR			
FD01-57-988	1	(ILLUST. NO.1)			
F100-57-988	1	(ILLUST. NO.2)			
57-988Z		COVER(L),RETRACTOR			
FD01-57-989	1	(ILLUST. NO.1)			
F100-57-989	1	(ILLUST. NO.2)			
3801 FD333*-301117					
3824 FD333*-301417					



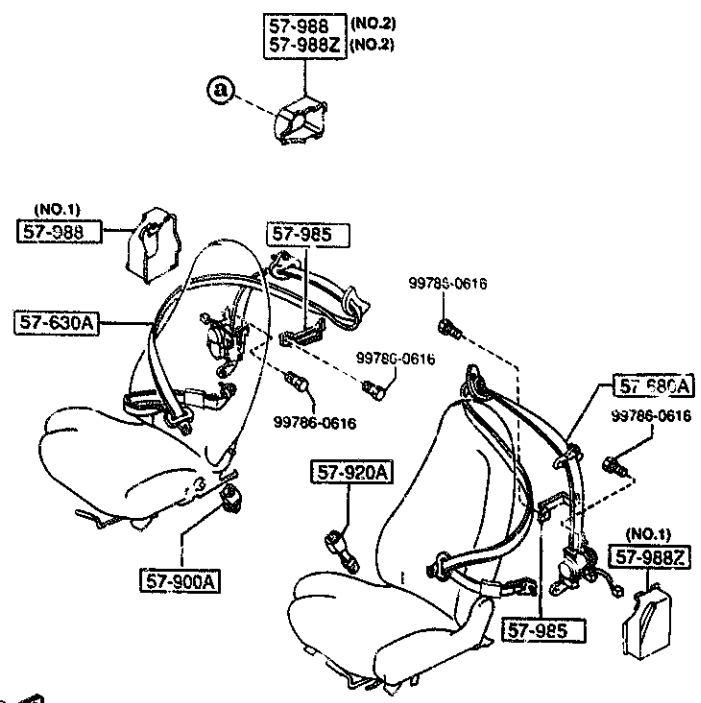
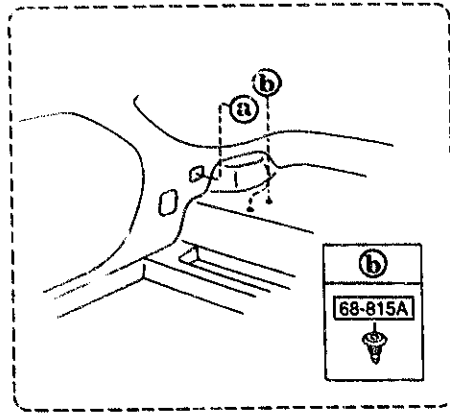

PART NO.	QTY	MODEL/RESTRICTION	MODEL/RESTRICTION	MODEL/RESTRICTION	FROM TO
68-815A		TACKER			
1011-68-815	4				

