

This file is available for free download at <http://www.iluvmyrx7.com>

This file is fully text-searchable – select Edit and Find and type in what you’re looking for. This file is intended more for online viewing than printing out so some graphics may not print 100% legibly, you can zoom in on them if you need to.



[www.iluvmyrx7.com](http://www.iluvmyrx7.com)

# SYSTEM WIRING DIAGRAMS

## Article Text

1993 Mazda RX7

For [www.iluvmyrx7.com](http://www.iluvmyrx7.com)

Copyright © 1998 Mitchell Repair Information Company, LLC

Wednesday, August 22, 2001 07:08AM

### ARTICLE BEGINNING

1993 System Wiring Diagrams  
Mazda - RX7

### COOLING FAN

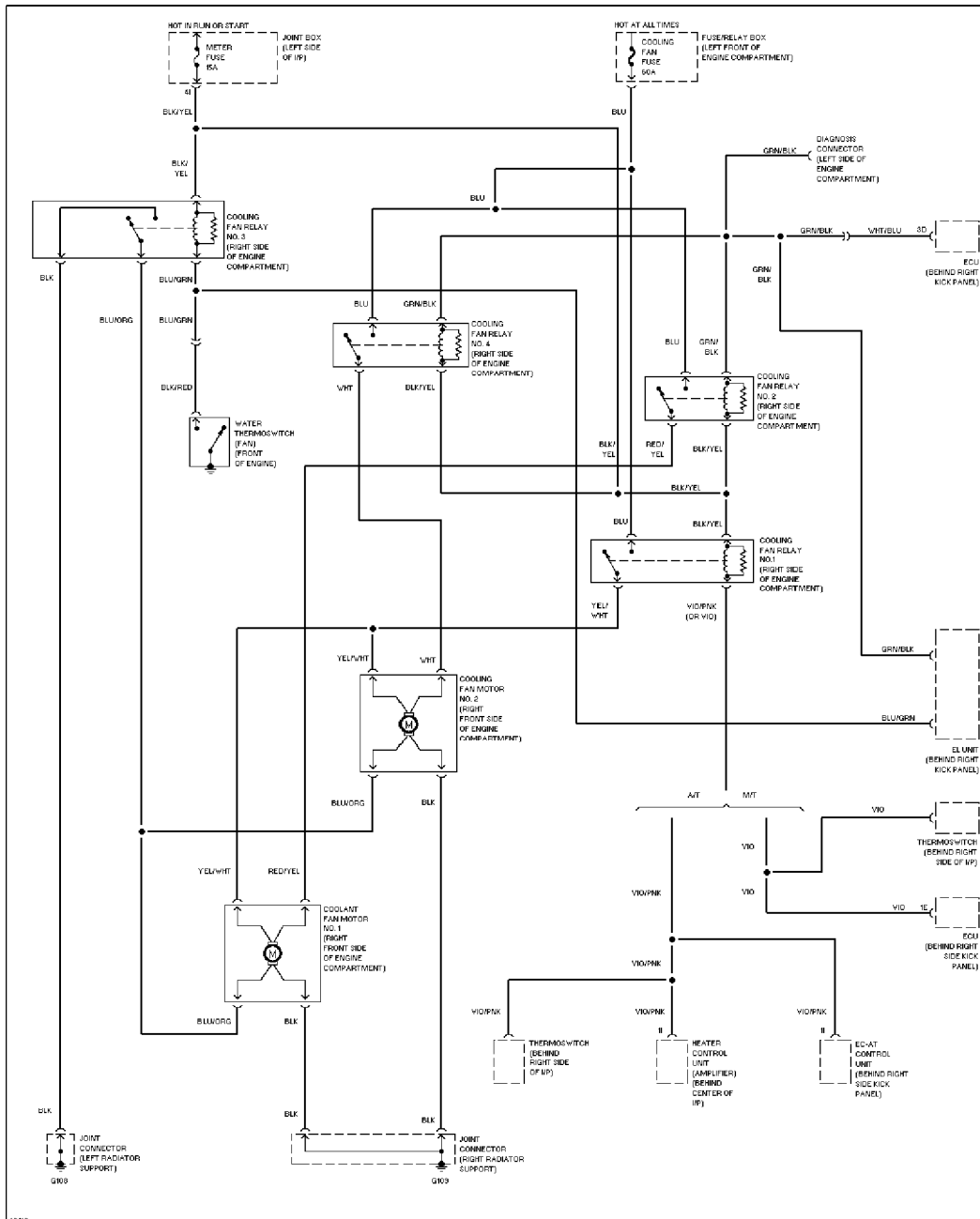

Cooling Fan Circuit

# SYSTEM WIRING DIAGRAMS

## Article Text (p. 2)

1993 Mazda RX7

For www.iluvmyrx7.com

Copyright © 1998 Mitchell Repair Information Company, LLC

Wednesday, August 22, 2001 07:08AM

### DEFOGGERS

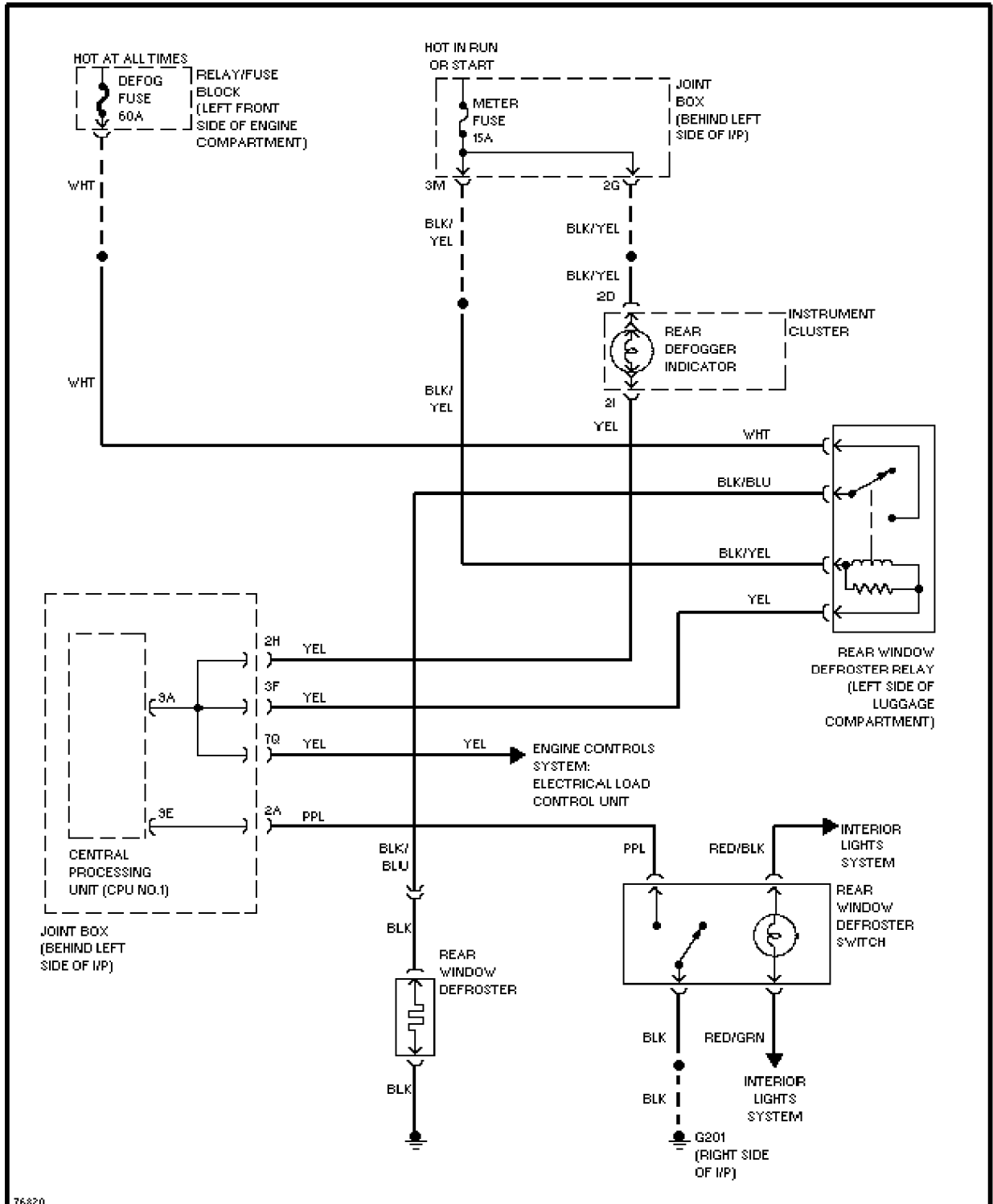

Defogger Circuit

# SYSTEM WIRING DIAGRAMS

## Article Text (p. 3)

1993 Mazda RX7

For [www.iluvmyrx7.com](http://www.iluvmyrx7.com)

Copyright © 1998 Mitchell Repair Information Company, LLC

Wednesday, August 22, 2001 07:08AM

### HORN

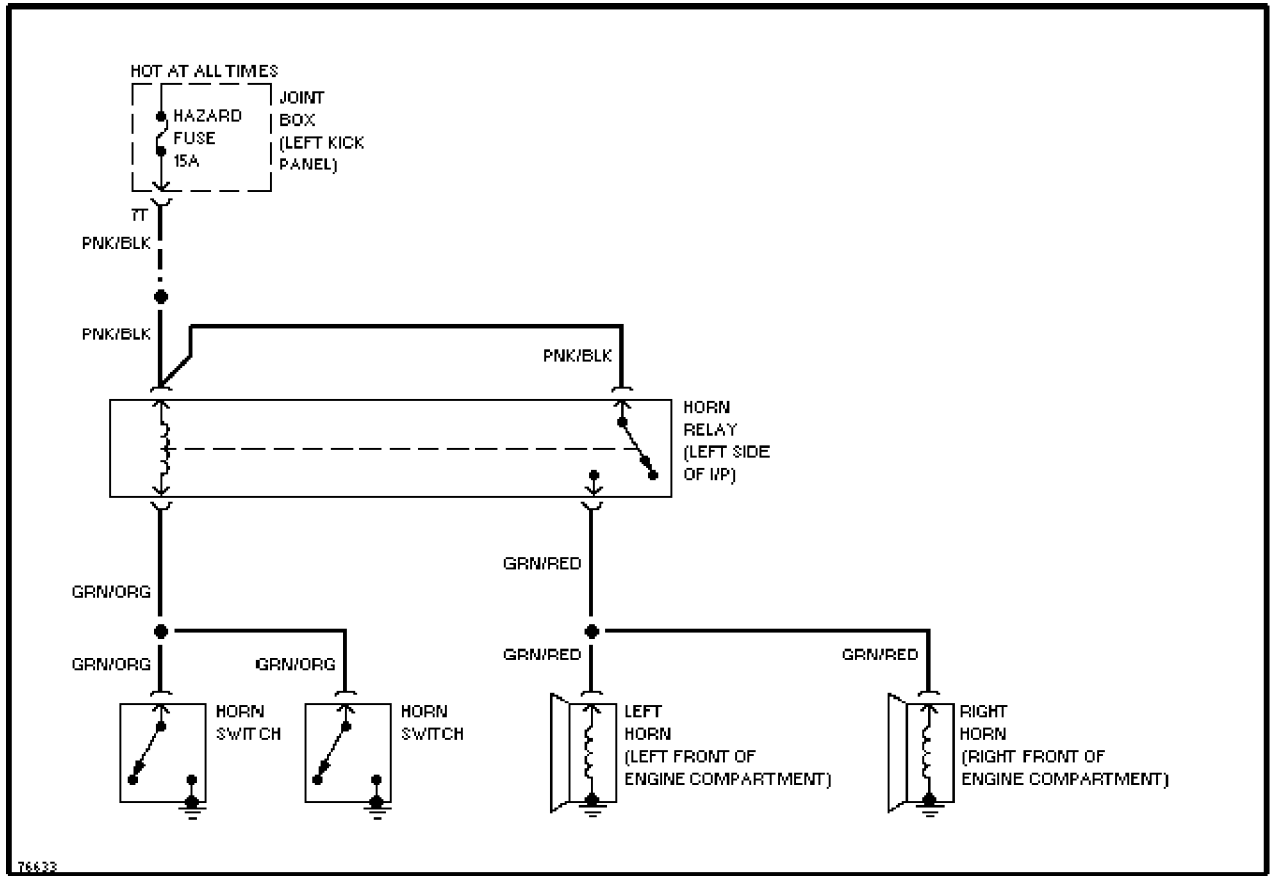

Horn Circuit

### POWER ANTENNA

# SYSTEM WIRING DIAGRAMS

## Article Text (p. 4)

1993 Mazda RX7

For [www.iluvmyrx7.com](http://www.iluvmyrx7.com)

Copyright © 1998 Mitchell Repair Information Company, LLC

Wednesday, August 22, 2001 07:08AM

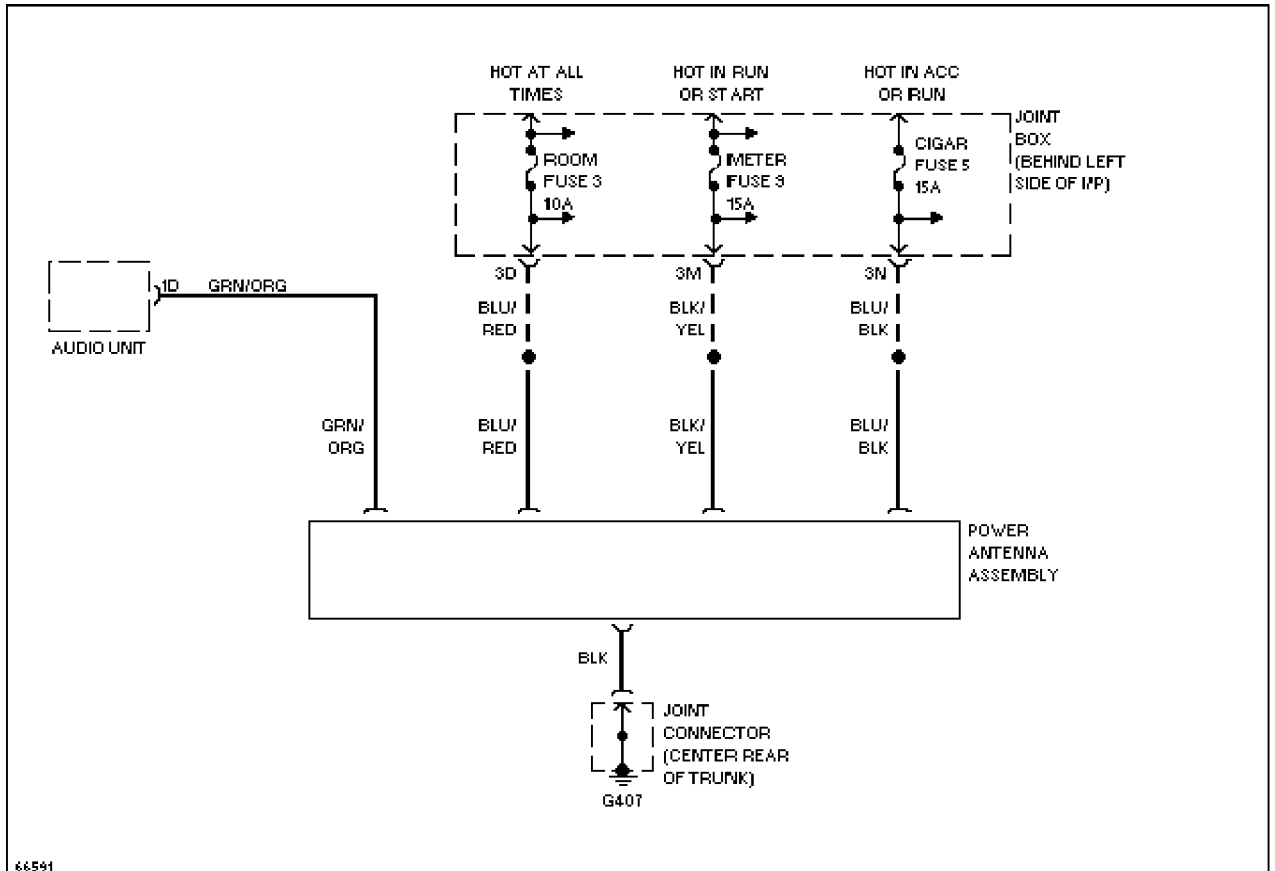

66591  
Power Antenna Circuit

## POWER DOOR LOCKS

# SYSTEM WIRING DIAGRAMS

## Article Text (p. 5)

1993 Mazda RX7

For [www.iluvmyrx7.com](http://www.iluvmyrx7.com)

Copyright © 1998 Mitchell Repair Information Company, LLC

Wednesday, August 22, 2001 07:08AM

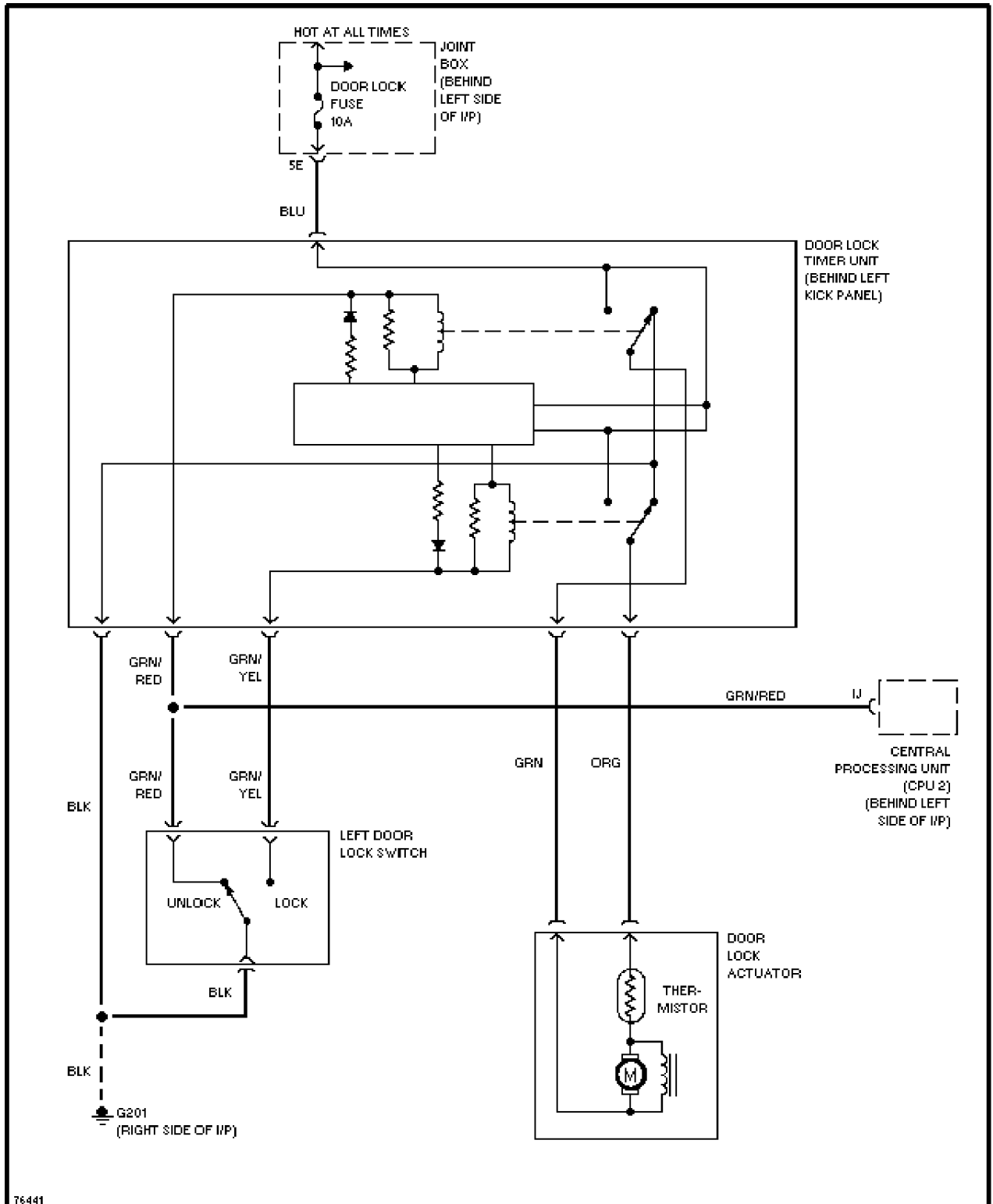

Power Door Lock Circuit

## POWER MIRRORS

# SYSTEM WIRING DIAGRAMS

## Article Text (p. 6)

1993 Mazda RX7

For [www.iluvmyrx7.com](http://www.iluvmyrx7.com)

Copyright © 1998 Mitchell Repair Information Company, LLC

Wednesday, August 22, 2001 07:08AM

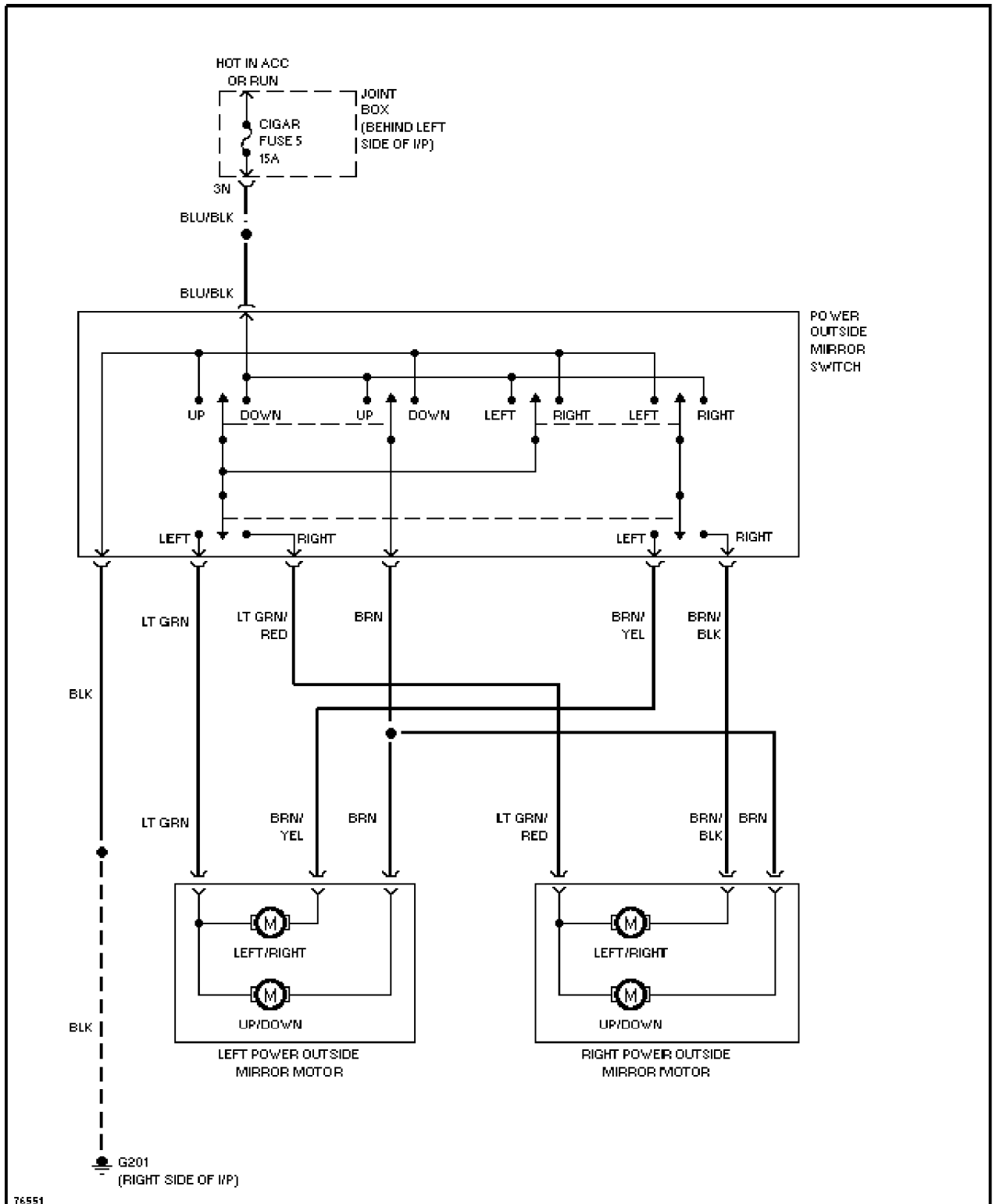

Power Mirror Circuit

# SYSTEM WIRING DIAGRAMS

## Article Text (p. 7)

1993 Mazda RX7

For www.iluvmyrx7.com

Copyright © 1998 Mitchell Repair Information Company, LLC

Wednesday, August 22, 2001 07:08AM

### POWER WINDOWS

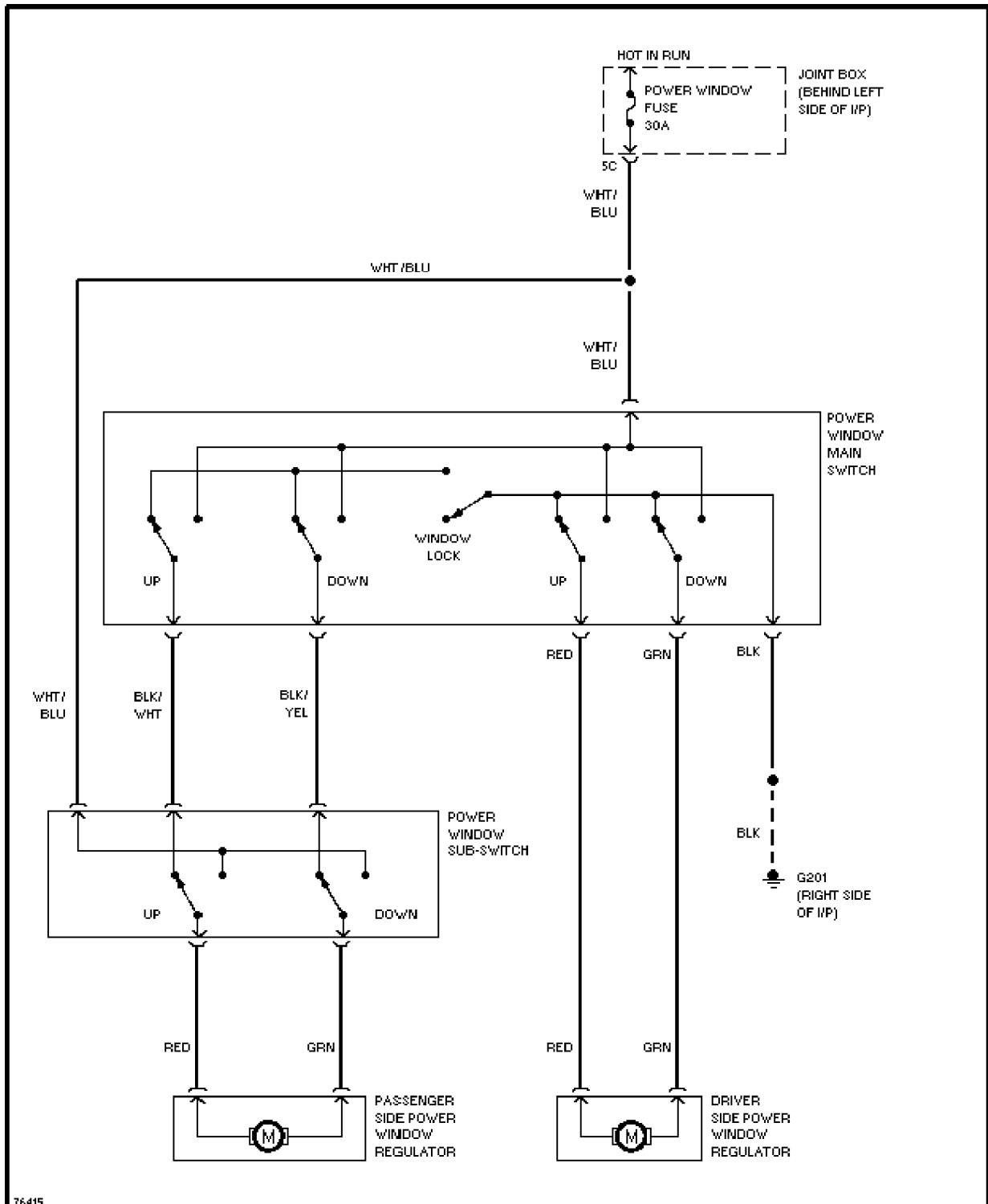

Power Window Circuit



# SYSTEM WIRING DIAGRAMS

Article Text (p. 8)

1993 Mazda RX7

For www.iluvmyrx7.com

Copyright © 1998 Mitchell Repair Information Company, LLC

Wednesday, August 22, 2001 07:08AM

## RADIO

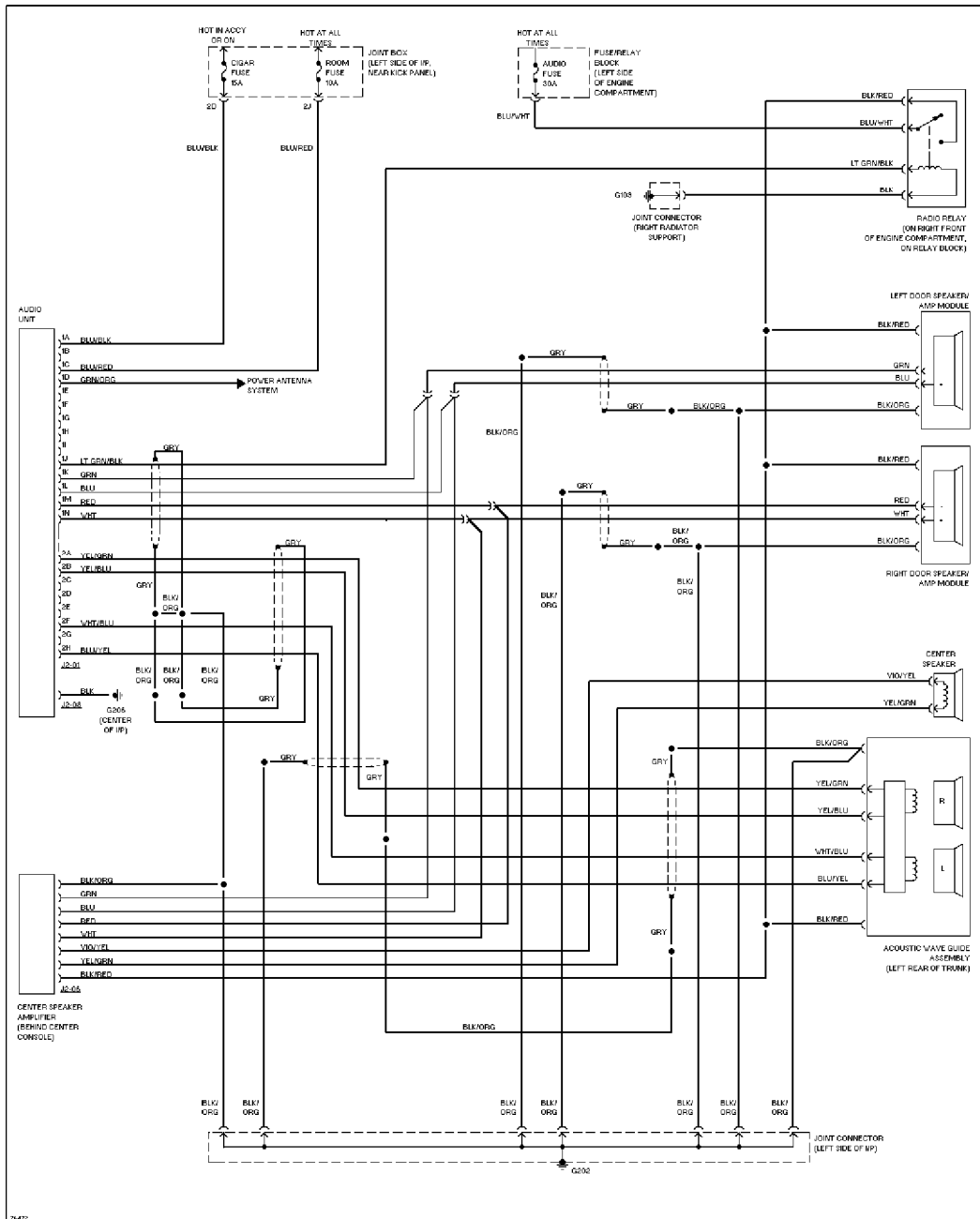

Radio Circuits, W/ Bose Acoustic Wave System

# SYSTEM WIRING DIAGRAMS

## Article Text (p. 9)

1993 Mazda RX7

For www.iluvmyrx7.com

Copyright © 1998 Mitchell Repair Information Company, LLC

Wednesday, August 22, 2001 07:08AM

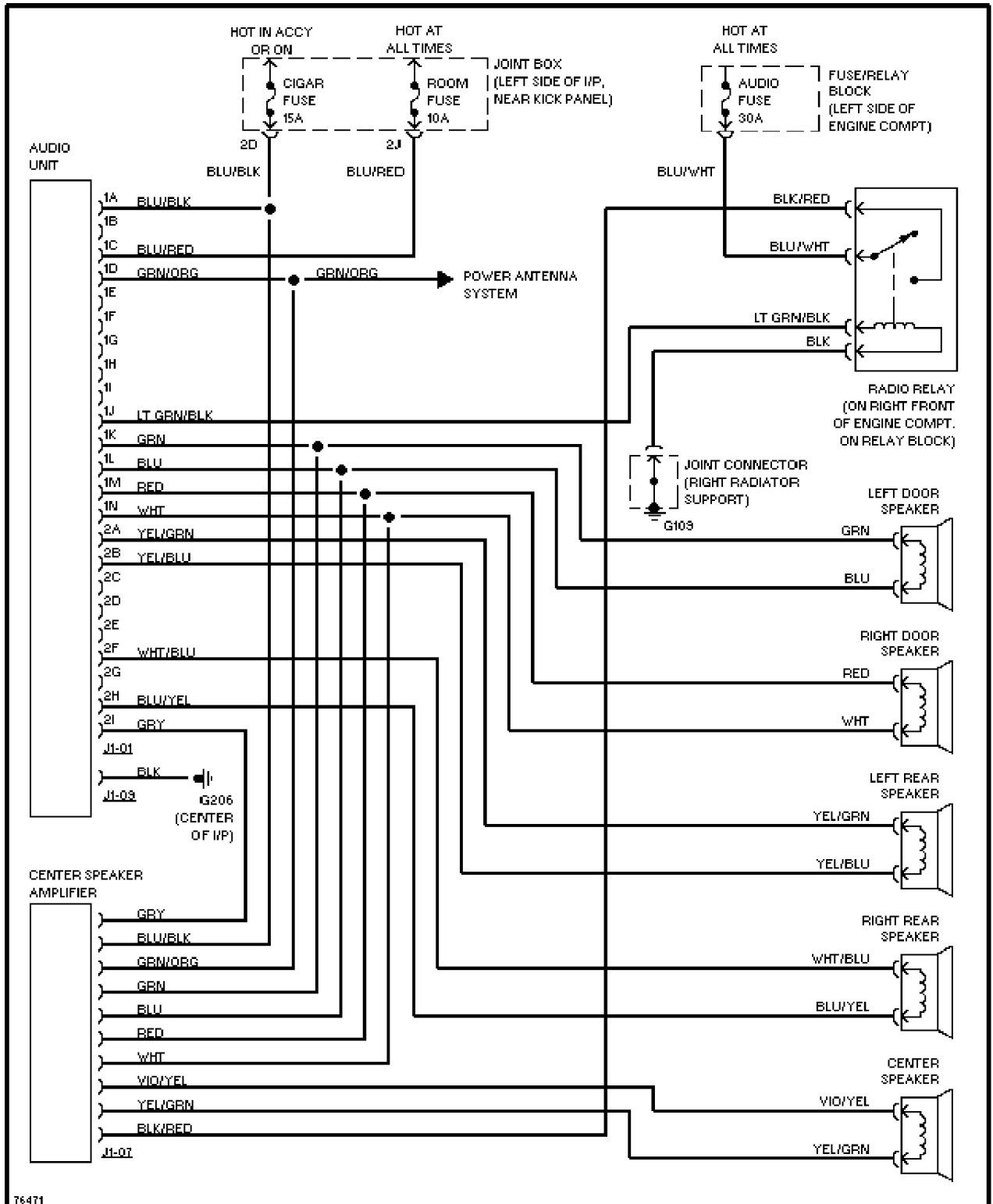

Radio Circuits, W/O Bose Acoustic Wave System

### STARTING/CHARGING

# SYSTEM WIRING DIAGRAMS

Article Text (p. 10)

1993 Mazda RX7

For www.iluvmyrx7.com

Copyright © 1998 Mitchell Repair Information Company, LLC

Wednesday, August 22, 2001 07:08AM

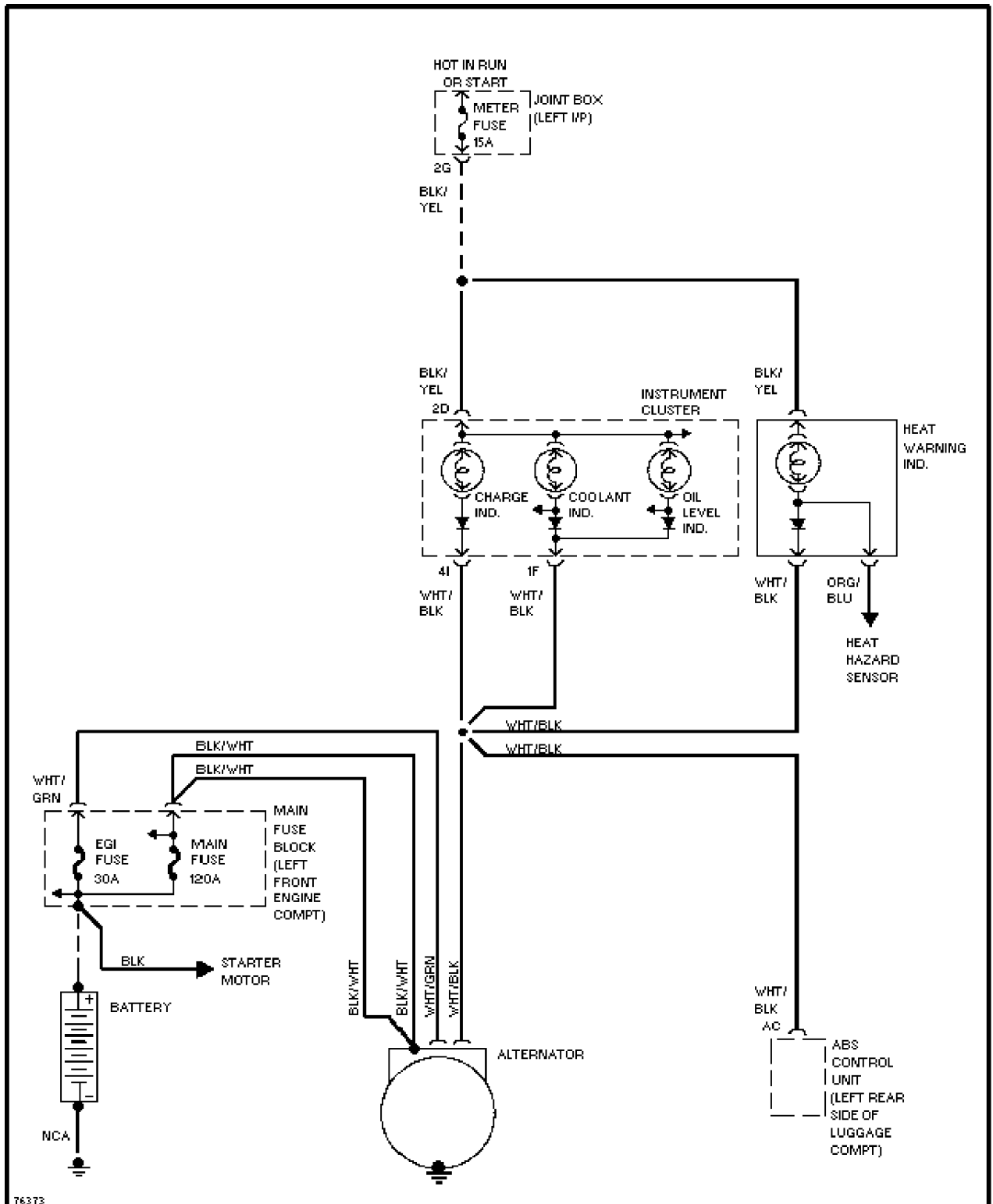

Charging Circuit

# SYSTEM WIRING DIAGRAMS

Article Text (p. 11)

1993 Mazda RX7

For www.iluvmyrx7.com

Copyright © 1998 Mitchell Repair Information Company, LLC

Wednesday, August 22, 2001 07:08AM

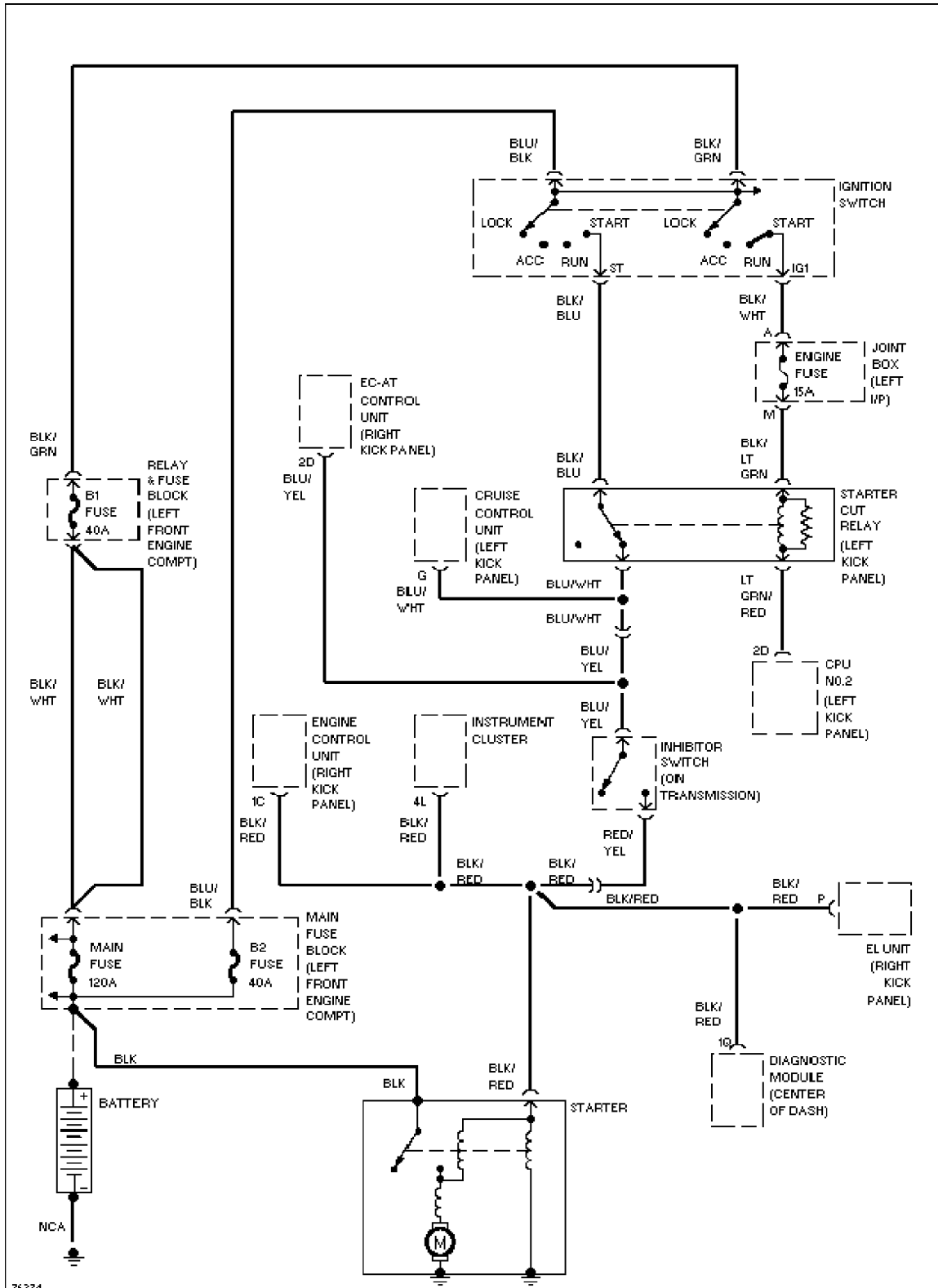

Starting Circuit, A/T

# SYSTEM WIRING DIAGRAMS

Article Text (p. 12)

1993 Mazda RX7

For www.iluvmyrx7.com

Copyright © 1998 Mitchell Repair Information Company, LLC

Wednesday, August 22, 2001 07:08AM

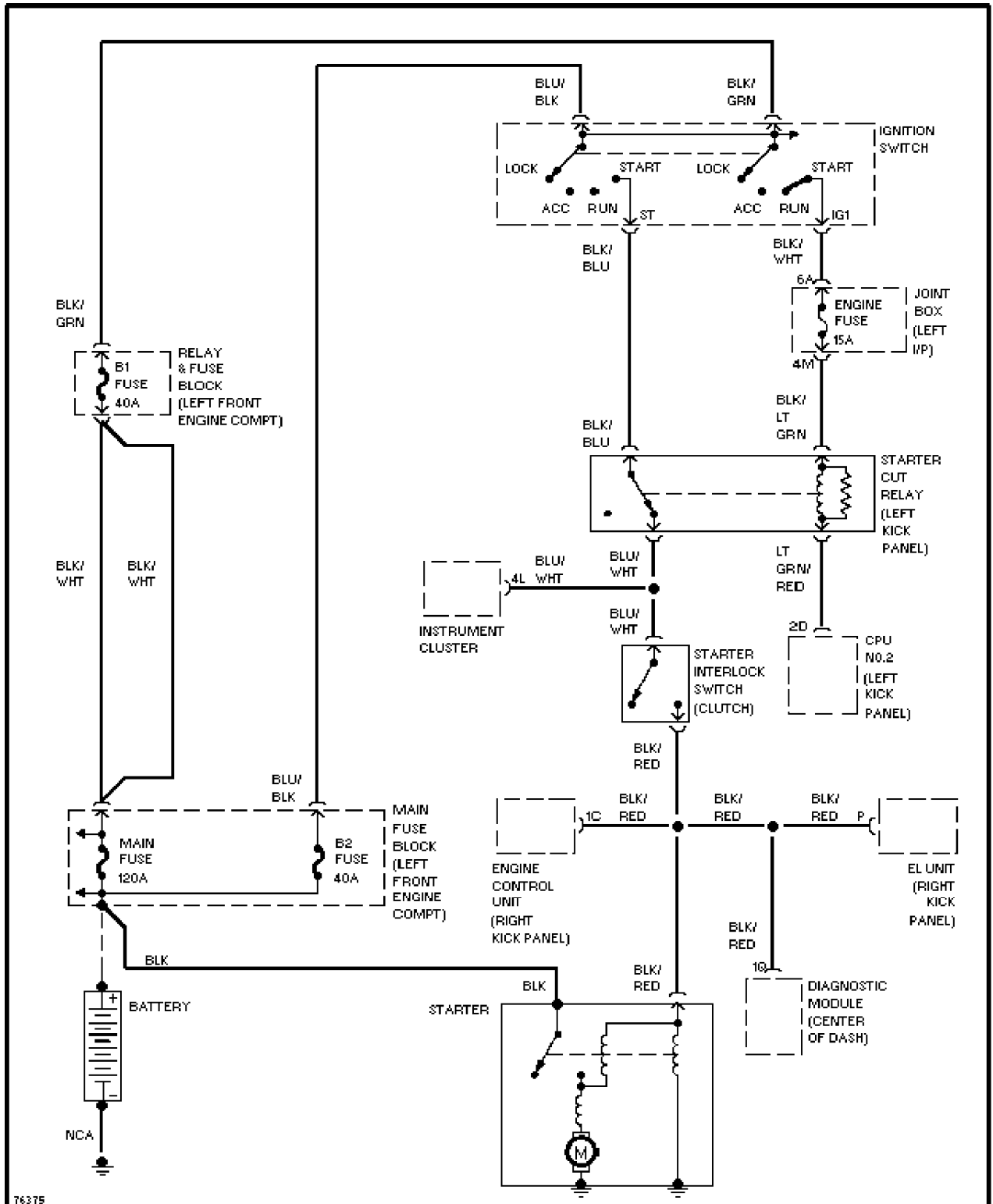

Starting Circuit, M/T

TRANSMISSION

# SYSTEM WIRING DIAGRAMS

Article Text (p. 13)

1993 Mazda RX7

For [www.iluvmyrx7.com](http://www.iluvmyrx7.com)

Copyright © 1998 Mitchell Repair Information Company, LLC

Wednesday, August 22, 2001 07:08AM

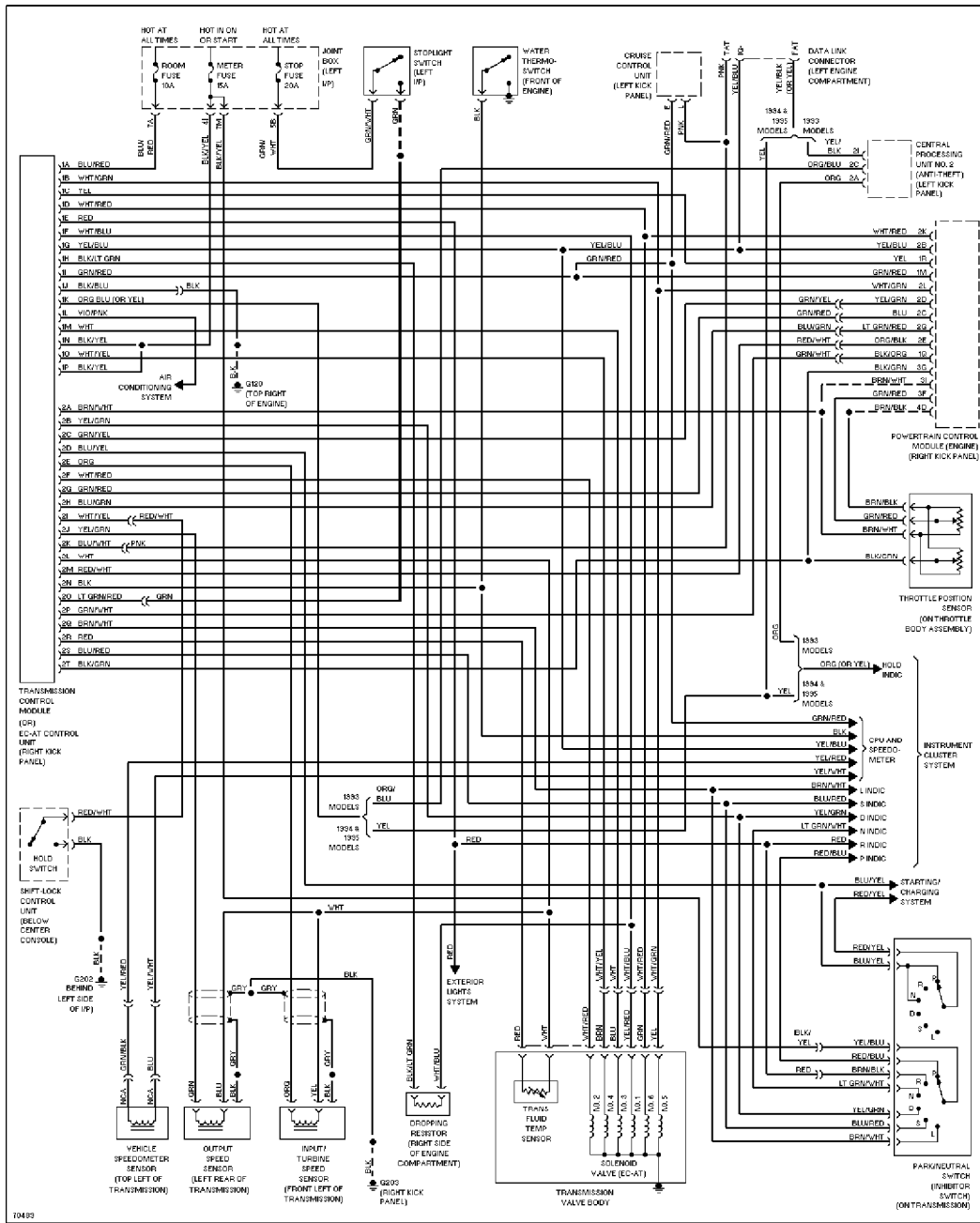

Transmission Circuit

WIPER/WASHER

# SYSTEM WIRING DIAGRAMS

Article Text (p. 14)

1993 Mazda RX7

For www.iluvmyrx7.com

Copyright © 1998 Mitchell Repair Information Company, LLC

Wednesday, August 22, 2001 07:08AM

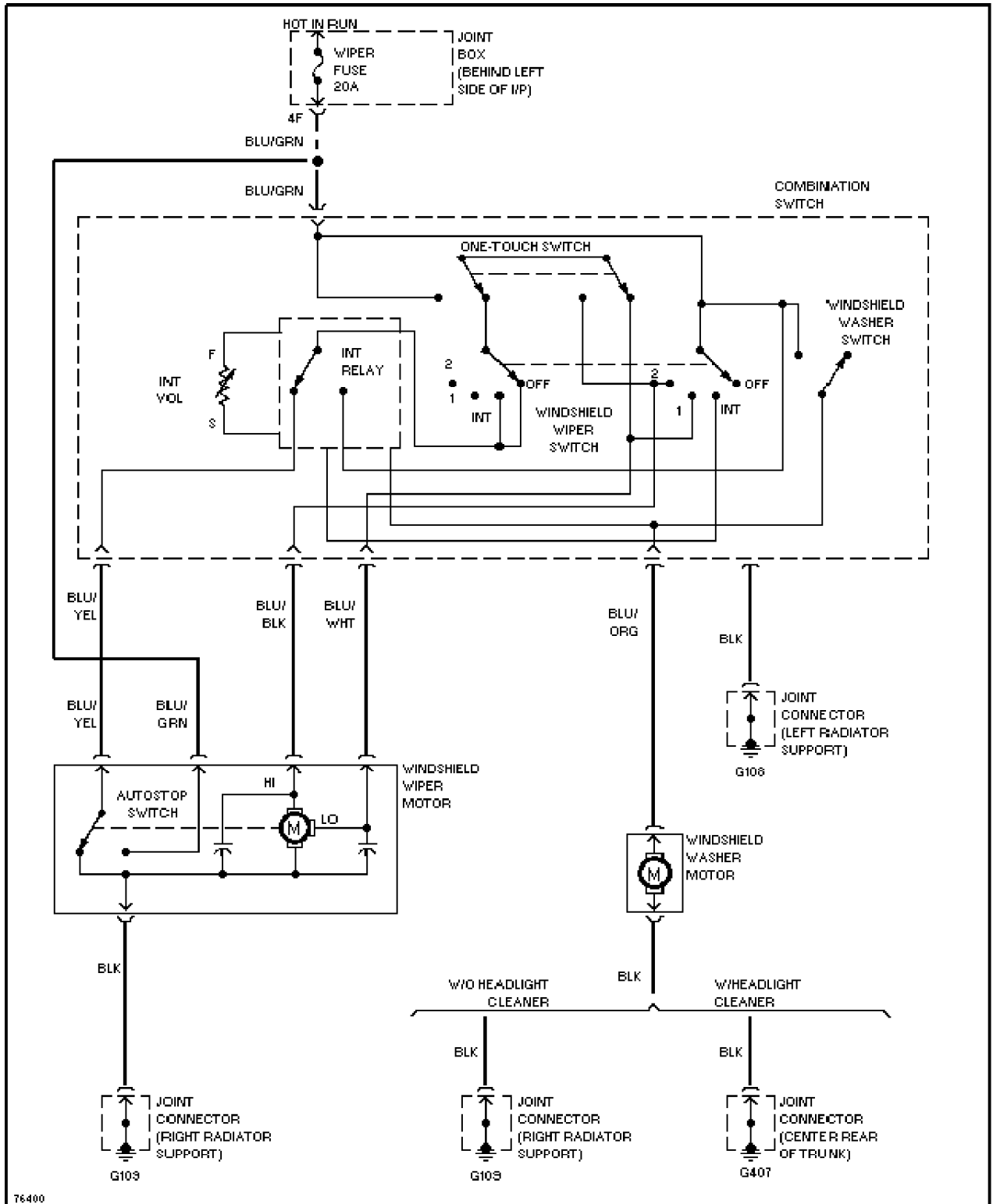

Front Washer/Wiper Circuit

# SYSTEM WIRING DIAGRAMS

Article Text (p. 15)

1993 Mazda RX7

For [www.iluvmyrx7.com](http://www.iluvmyrx7.com)

Copyright © 1998 Mitchell Repair Information Company, LLC

Wednesday, August 22, 2001 07:08AM

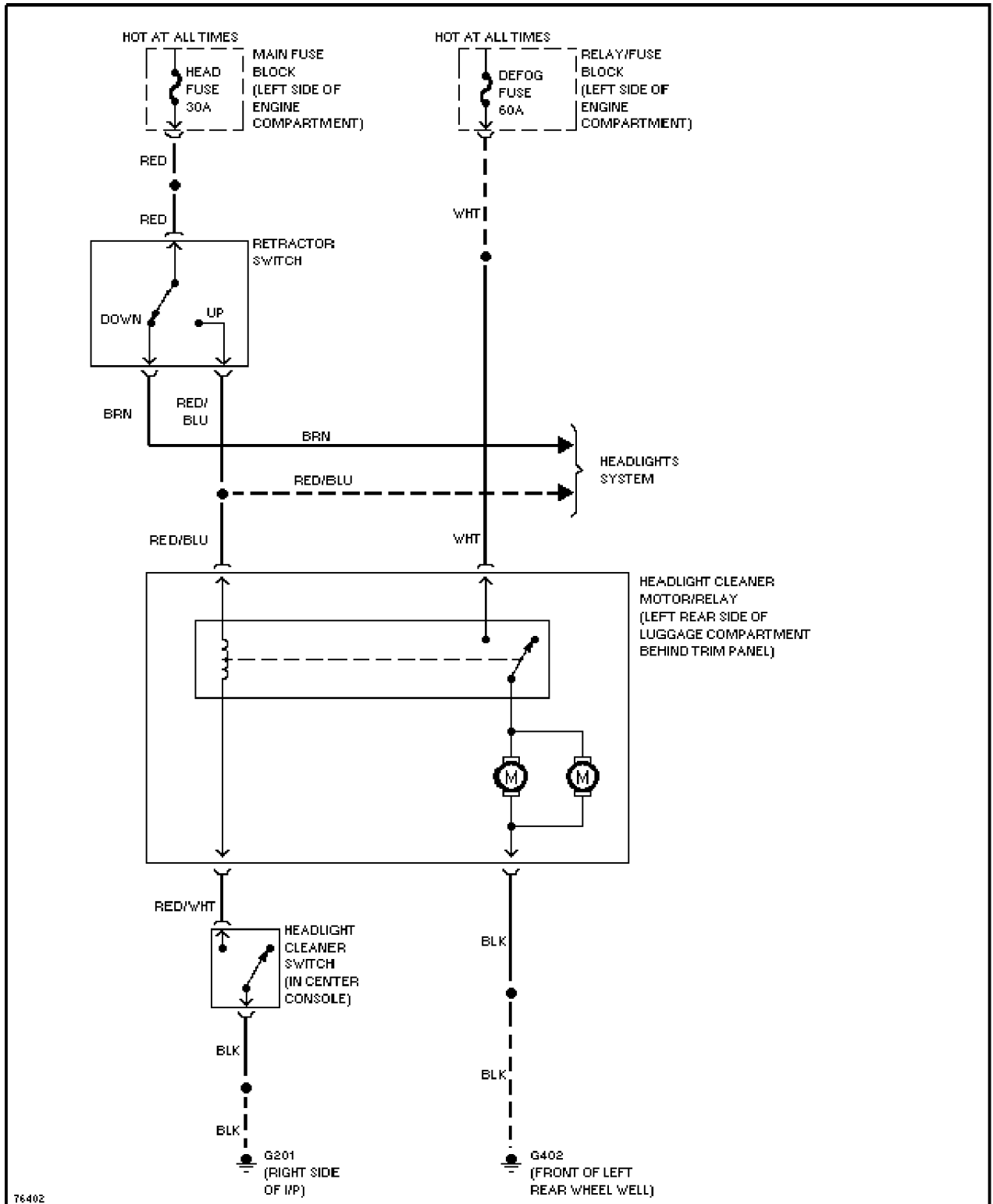

Headlamp Washer Circuit



# SYSTEM WIRING DIAGRAMS

## Article Text (p. 16)

1993 Mazda RX7

For www.iluvmyrx7.com

Copyright © 1998 Mitchell Repair Information Company, LLC

Wednesday, August 22, 2001 07:08AM

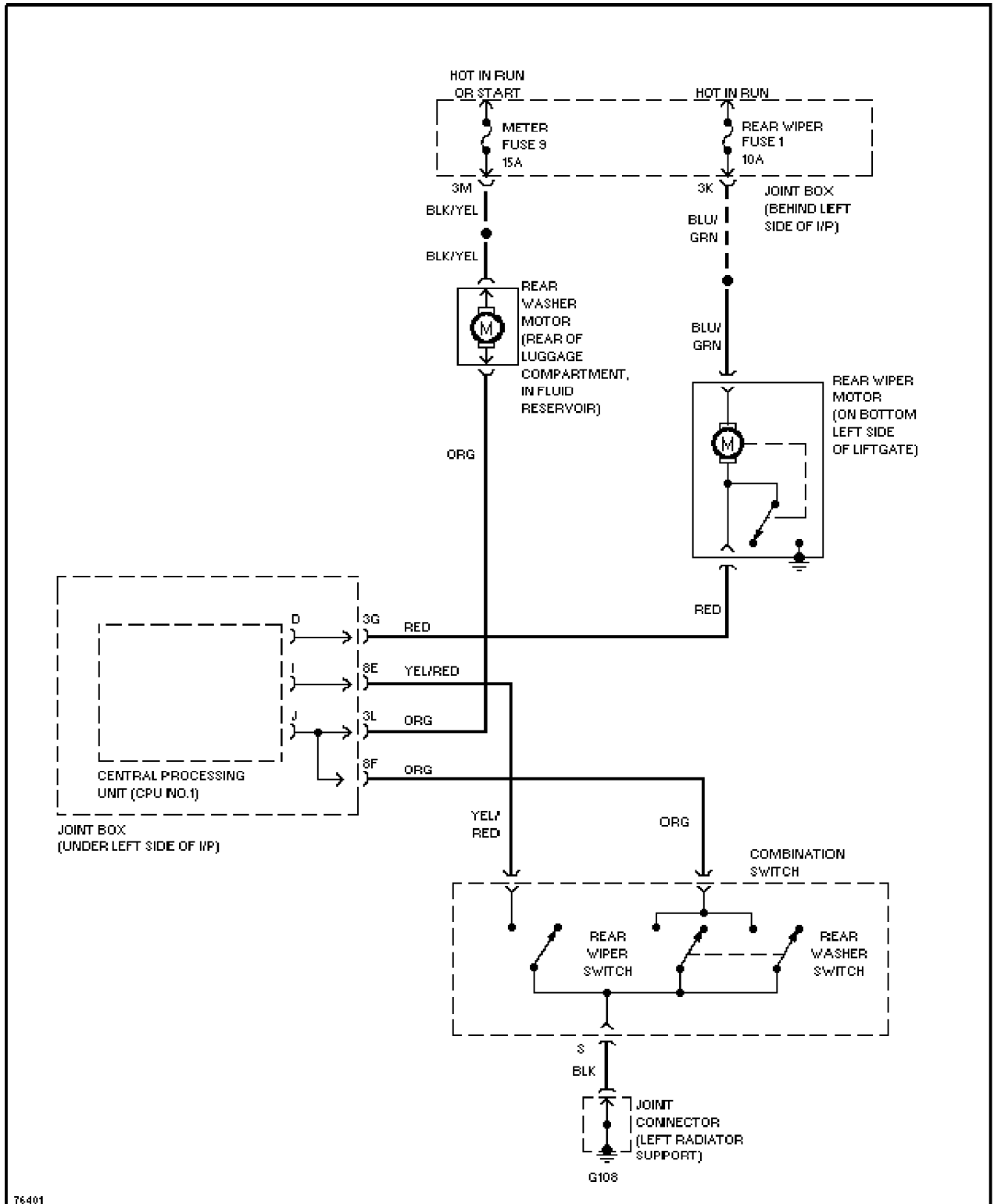

Rear Washer/Wiper Circuit

END OF ARTICLE

# WIRING DIAGRAM SYMBOLS

## Article Text

1993 Mazda RX7

For [www.iluvmyrx7.com](http://www.iluvmyrx7.com)

Copyright © 1998 Mitchell Repair Information Company, LLC  
Wednesday, August 22, 2001 07:09AM

## ARTICLE BEGINNING

WIRING DIAGRAMS

How To Use The Wiring Diagrams

## WIRING DIAGRAMS

### INTRODUCTION

The wiring diagrams and technical service bulletins, containing wiring diagram changes, are obtained from the domestic and import manufacturers. These are checked for accuracy and are all redrawn into a consistent format for easy use.

All diagrams are arranged with the front of the vehicle at the left side of the first page and the rear of the vehicle at the right side of the last page. Accessories are shown near the end of the diagram.

Components are shown in their approximate location on the vehicle. Due to the constantly increasing number of components on vehicles today, it is impossible to show exact locations.

In the past, when cars were simpler, diagrams were simpler. All components were connected by wires, and diagrams seldom exceeded 4 pages in length. Today some wiring diagrams require more than 16 pages. It would be impractical to expect a service technician to trace a wire from page 1 across every page to page 16.

Removing some of the wiring maze reduces eyestrain and time wasted searching across several pages. Today, the majority of diagrams now follow a much improved format, which permits space for internal switch details and connector shapes.

Any wires that don't connect directly to their components are identified on the diagram to indicate where they go. There is a legend on the first page of each diagram, detailing component location. It refers you to sub-systems, using grid NUMBERS at the top and bottom of the page and grid LETTERS on each side. This grid system works in a manner similar to that of a road map.

### HOW TO USE THE WIRING DIAGRAMS

1) On the first page of the diagram, you will find a listing of major electrical components or systems. Locate the specific component or system you wish to trace. A grid number and letter will follow the component's name.

2) Use the grid NUMBERS (arranged horizontally across the top and bottom of each page) to find the page of the wiring diagram that contains the component you're seeking. When you reach this page, use the grid LETTERS on the side of the page to determine the component's vertical location.

3) Locate the circuit you need to service. The internals are shown for switches and relays to assist you in understanding how the circuit operates.

NOTE: In some of the newer wiring diagram articles in this



# WIRING DIAGRAM SYMBOLS

## Article Text (p. 3)

1993 Mazda RX7

For www.iluvmyrx7.com

Copyright © 1998 Mitchell Repair Information Company, LLC  
Wednesday, August 22, 2001 07:09AM

Blue	.....	BLU	.....	BU
Brown	.....	BRN	.....	BN
Clear	.....	CLR	.....	CR
Dark Blue	.....	DK BLU	.....	DK BU
Dark Green	.....	DK GRN	.....	DK GN
Green	.....	GRN	.....	GN
Gray	.....	GRY	.....	GY
Light Blue	.....	LT BLU	.....	LT BU
Light Green	.....	LT GRN	.....	LT GN
Orange	.....	ORG	.....	OG
Pink	.....	PNK	.....	PK
Purple	.....	PPL	.....	PL
Red	.....	RED	.....	RD
Tan	.....	TAN	.....	TN
Voilet	.....	VIO	.....	VI
White	.....	WHT	.....	WT
Yellow	.....	YEL	.....	YL

AA

### WIRING DIAGRAM SYMBOL IDENTIFICATION

NOTE: Standard wiring symbols are used on diagrams. The list below will help clarify any symbols that are not easily understood at a glance. Most components are labeled "Motor", "Switch" or "Relay" in addition to being drawn with the standard symbol.

### WIRING DIAGRAM SYMBOLS

Views of the symbols used in the WIRING DIAGRAM articles are in the following graphics. See Figs. 3 through 25.



Fig. 3: Circuit Breaker



Fig. 4: Coil (Internal)



Fig. 5: Connector

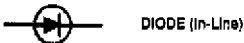

Fig. 6: Diode (In-Line)



Fig. 7: Diode (Internal)



Fig. 8: Diode (Light Emitting)

# WIRING DIAGRAM SYMBOLS

## Article Text (p. 4)

1993 Mazda RX7

For [www.iluvmyrx7.com](http://www.iluvmyrx7.com)

Copyright © 1998 Mitchell Repair Information Company, LLC  
Wednesday, August 22, 2001 07:09AM



Fig. 9: Defogger Grid



Fig. 10: Fuse



Fig. 11: Fusible Link



Fig. 12: Ground

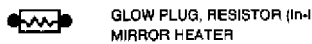

Fig. 13: Glow Plug Resistor (In-Line) or Mirror Heater



Fig. 14: Injector (Diesel) or Photocell (Gasoline)

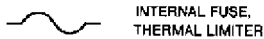

Fig. 15: Internal Fuse, Thermal Limiter



Fig. 16: Lamp (Dual Element)



Fig. 17: Lamp (Single Element)



Fig. 18: Motor



Fig. 19: Resistor (Internal)



Fig. 20: Sensor, Thermistor

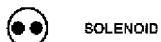

Fig. 21: Solenoid



Fig. 22: Solid State Device, Transistor



Fig. 23: Switch (Internal)

## WIRING DIAGRAM SYMBOLS

### Article Text (p. 5)

1993 Mazda RX7

For [www.iluvmyrx7.com](http://www.iluvmyrx7.com)

Copyright © 1998 Mitchell Repair Information Company, LLC  
Wednesday, August 22, 2001 07:09AM



TWO PIN SWITCH

Fig. 24: Two Pin Switch



VARIABLE RESISTOR  
OR POTENTIOMETER

Fig. 25: Variable Resistor or Potentiometer

**END OF ARTICLE**

**WIRING DIAGRAMS**  
**Article Text**  
 1993 Mazda RX7  
 For www.iluvmyrx7.com  
 Copyright © 1998 Mitchell Repair Information Company, LLC  
 Wednesday, August 22, 2001 07:08AM

**ARTICLE BEGINNING**

1993 Wiring Diagrams  
 Mazda Wiring Diagrams

Mazda; RX7

**IDENTIFICATION**

**COMPONENT LOCATION MENU**

COMPONENT LOCATIONS TABLE

AA

Component	Figure No. (Location)
A/C RELAY	9 (C 34)
A/P RLY	2 (A 4)
ABS CTRL UNIT	7 (B-C 24)
ALTERNATOR	1 (B 3)
BACK-UP LT SW (M/T)	12 (B 47)
BATTERY	1 (A 2)
BLOWER MTR RLY	9 (B 33)
CIG LTR	8 (D 28)
CIRCUIT OPENING RELAY	3 (A 11)
CLUTCH SW (M/T)	3 (D 8)
COMBINATION SW	6 (C-D 20-23)
CPU #2	10 (A-C 36)
CRUISE CONTROL	8 (E 29)
CRUISE CONTROL UNIT	7 (D-E 24)
DATA LINK CONN	11 (D-E 41)
DIAGNOSTIC MODULE (AIRBAG)	10 (D-E 36)
DIR SWITCH	6 (D 22)
DOOR LOCK TIMER UNIT	7 (C 26)
DOOR SWITCH	9 (D 33)
EC-AT CONTROL SYSTEM	8 (A-B 29-31)
EGI MAIN RLY	2 (A 5)
EL UNIT	2 (B 7)
ENGINE CONTROL UNIT	2,3 (B-E 4-8)
FOG LT SW	1 (B 2)
FUEL PUMP	3 (A 11)
GLOVE BOX LT	12 (A 45)
HEADLT RELAY	1 (E 1)
HEAT WARNING	11 (A-E 40)
HEATER CTRL UNIT	9 (A-D 32)
HORN RLY	1 (C 2)
HYDRAULIC UNIT	10 (A 38-39)
IGNITION SW	6 (A 23)
ILLUM LIGHTS	9 (E 32-35)
INHIBITOR SW	8 (A-B 28)
INST CLSTR	11 (A-E 40-43)
INTERIOR LTS	9 (D 33)

**WIRING DIAGRAMS**

**Article Text (p. 2)**

1993 Mazda RX7

For [www.iluvmyrx7.com](http://www.iluvmyrx7.com)

Copyright © 1998 Mitchell Repair Information Company, LLC  
Wednesday, August 22, 2001 07:08AM

JOINT BOX ..... 4,5 (B-D 14-18)  
KEY INTERLOCK SOL ..... 8 (B 29)  
LIGHT SW ..... 6 (D 23)  
MAGNETIC CLUTCH ..... 2 (A 4)  
MAIN FUSE BLOCK ..... 1 (A 2)  
PANEL LAMP CTRL SWITCH ..... 9 (E 32)  
POWER ANTENNA ASSEMBLY ..... 12 (A 44)  
POWER MIRROR SW ..... 12 (C-D 44)  
POWER WINDOW MAIN SW ..... 12 (C-E 44)  
RADIO RELAY ..... 6 (B 23)  
REAR WINDOW DEFROSTER RLY ..... 12 (B 44)  
REAR WINDOW DEFROSTER SW ..... 12 (C 46)  
REAR WIPER MTR ..... 12 (B 46)  
REAR WIPER/WASHER SW ..... 12 (B 44)  
RELAY AND FUSE BLOCK ..... 6 (A-B 20-21)  
RETRACTABLE HEADLT RLY ..... 1 (D 3)  
RETRACTABLE HEADLT SW ..... 1 (D 2)  
SHIFT LOCK CONTROL UNIT ..... 8 (C 28)  
STARTER ..... 1 (B 2)  
STARTER CUT RELAY ..... 1 (C 3)  
STARTING INTERLOCK SW (M/T) ..... 1 (C 3)  
STOP LT SW ..... 12 (C 47)  
SUNROOF SW ..... 10 (C 38)  
THROTTLE SENSOR ..... 3 (A 10)  
TNS RELAY ..... 6 (A 23)  
WASHER MOTOR ..... 6 (D 20)  
WIPER MOTOR ..... 6 (E 20)  
AA

**WIRING DIAGRAMS**



# WIRING DIAGRAMS

Article Text (p. 3)

1993 Mazda RX7

For www.iluvmyrx7.com

Copyright © 1998 Mitchell Repair Information Company, LLC

Wednesday, August 22, 2001 07:08AM

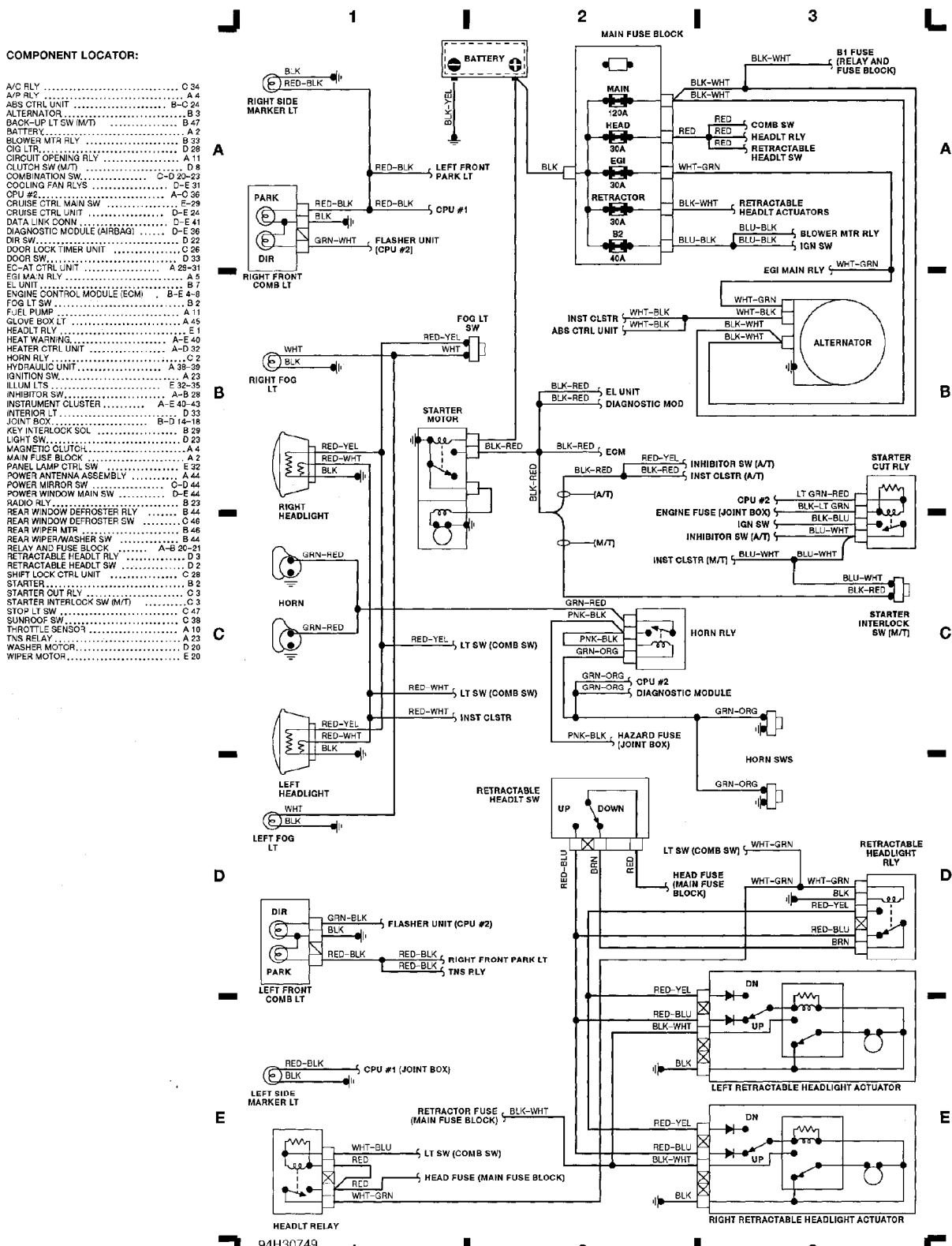

Fig. 1: Engine Compartment & Headlights (Grids 1-3)

**WIRING DIAGRAMS**  
**Article Text (p. 4)**  
 1993 Mazda RX7  
 For www.iluvmyrx7.com  
 Copyright © 1998 Mitchell Repair Information Company, LLC  
 Wednesday, August 22, 2001 07:08AM

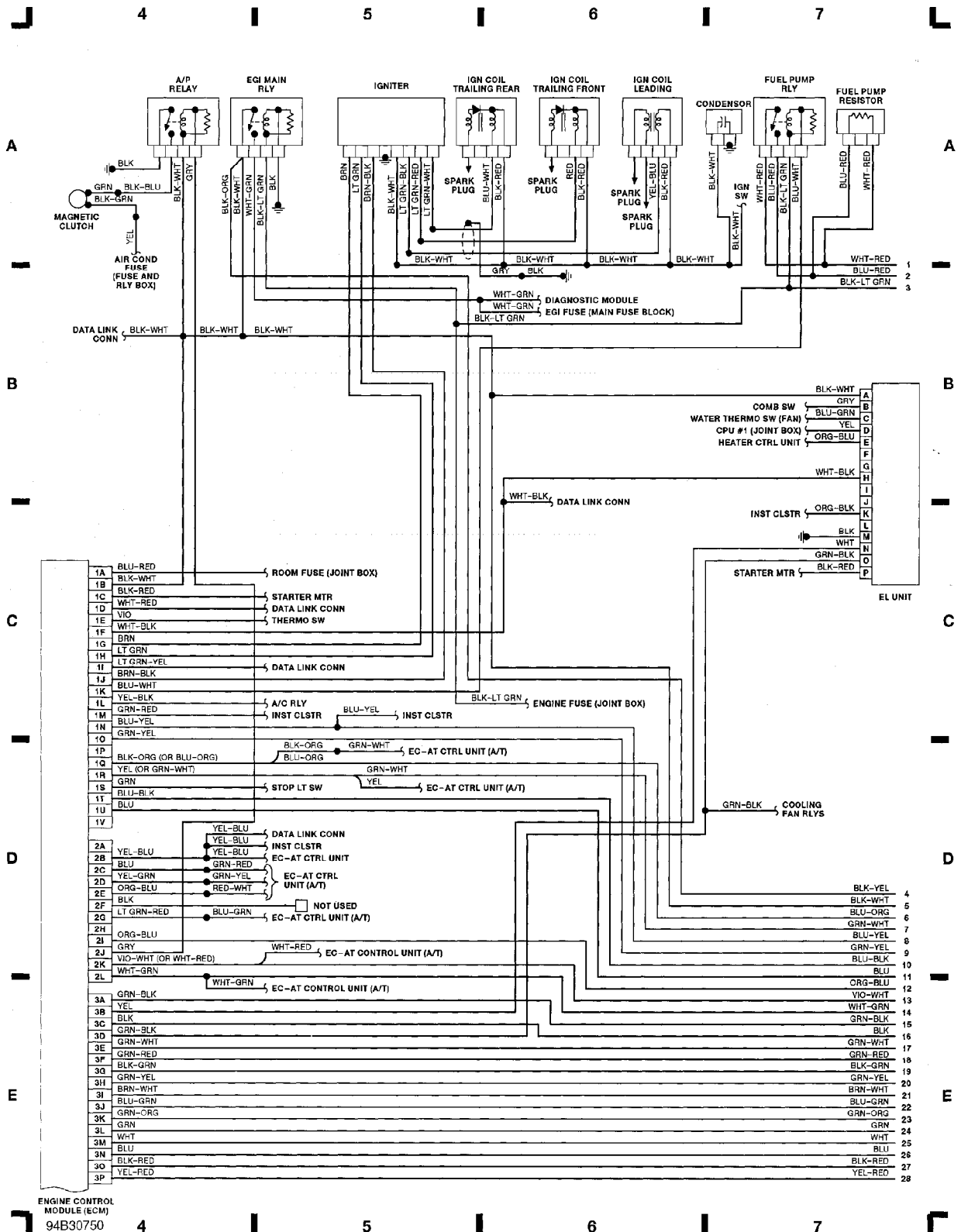

Fig. 2: Engine Ctrl Mdl, EL Unit, Fuel Pump Rly (Grids 4-7)

**WIRING DIAGRAMS**  
**Article Text (p. 5)**  
 1993 Mazda RX7  
 For www.iluvmyrx7.com  
 Copyright © 1998 Mitchell Repair Information Company, LLC  
 Wednesday, August 22, 2001 07:08AM

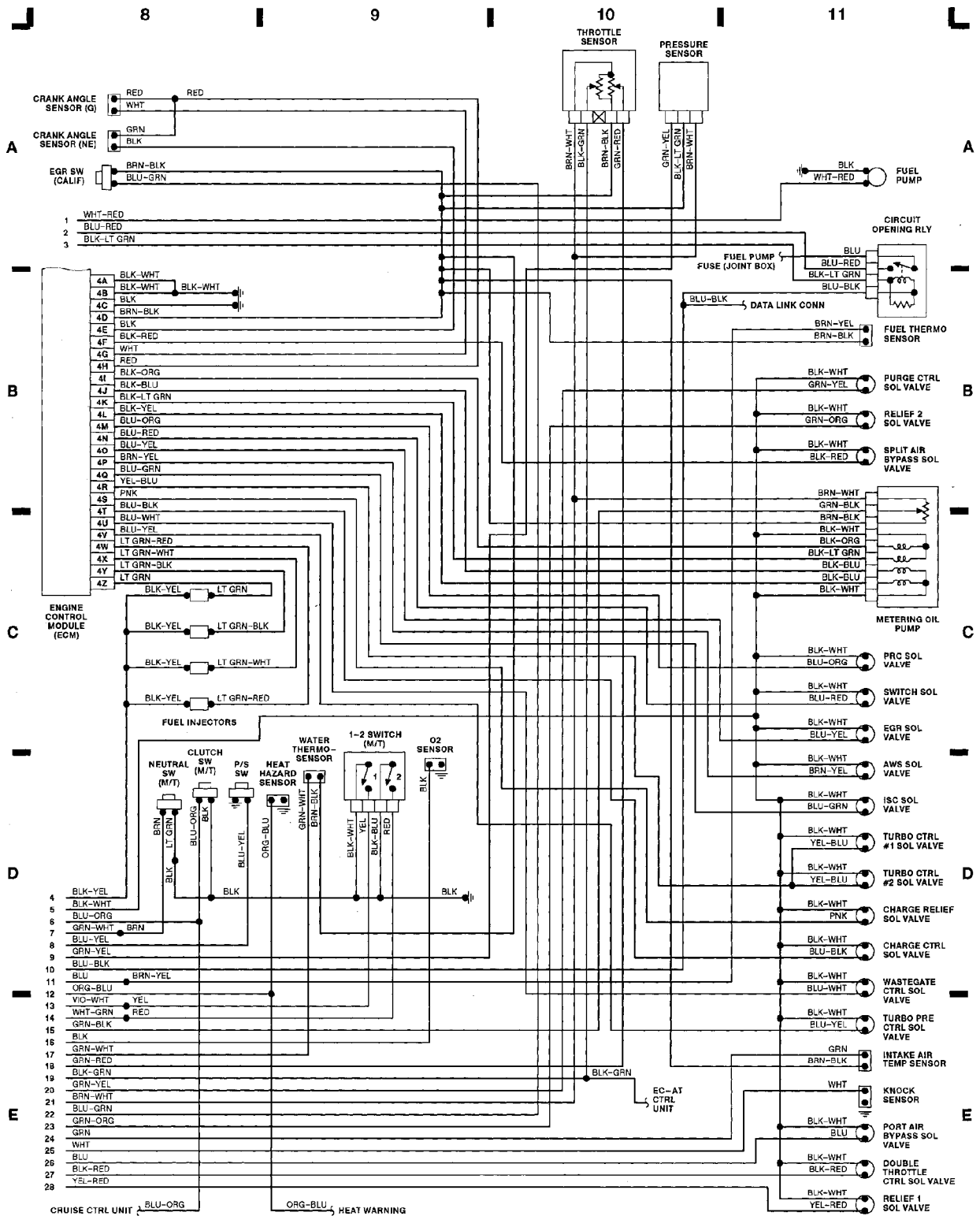
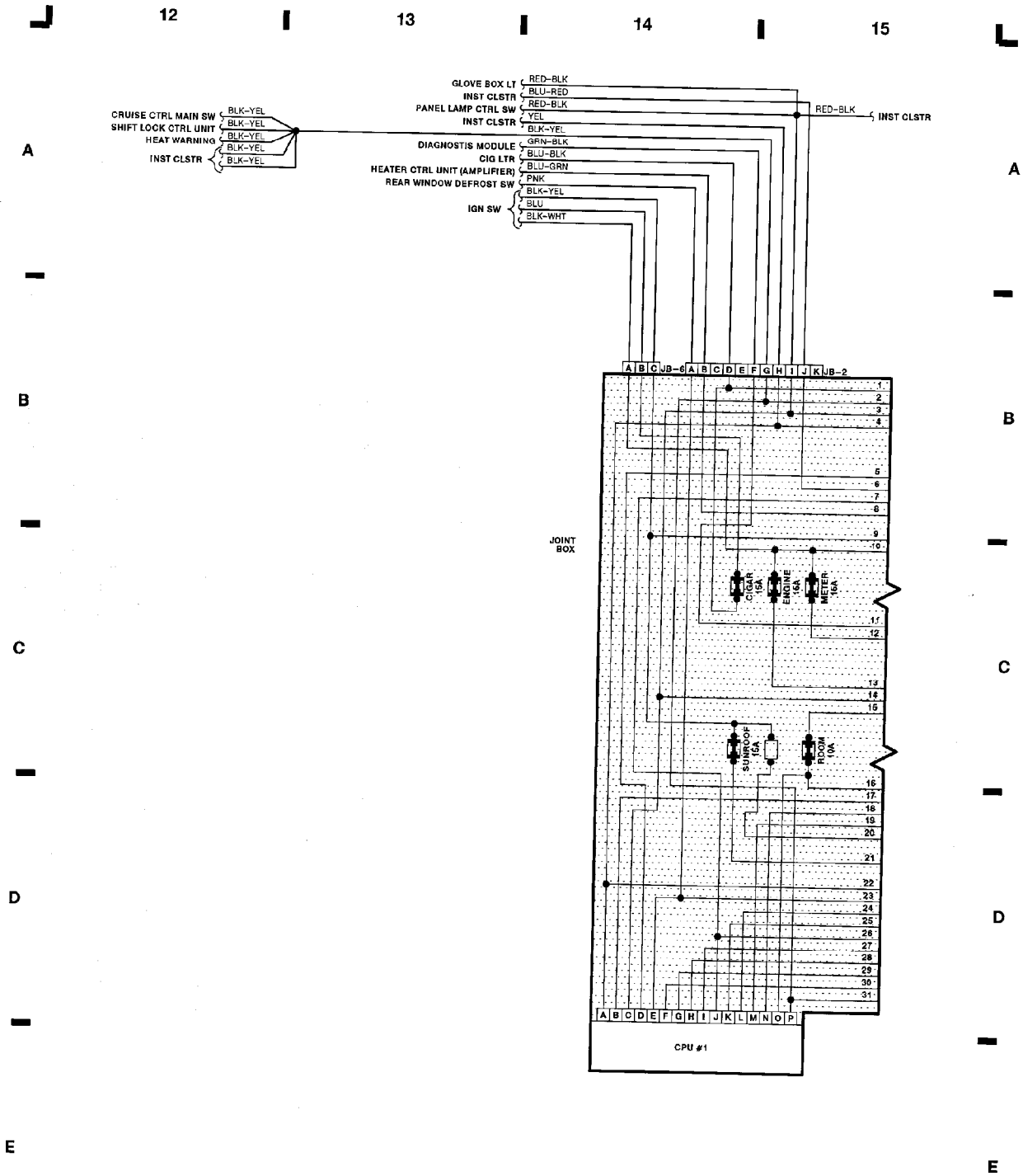

Fig. 3: Engine Ctrl Mdl, Throttle Sensor (Grids 8-11)

**WIRING DIAGRAMS**  
**Article Text (p. 6)**  
 1993 Mazda RX7  
 For www.iluvmyrx7.com  
 Copyright © 1998 Mitchell Repair Information Company, LLC  
 Wednesday, August 22, 2001 07:08AM



94D30752  
 Fig. 4: Joint Box (Grids 12-15)

**WIRING DIAGRAMS**  
**Article Text (p. 7)**  
 1993 Mazda RX7  
 For www.iluvmyrx7.com  
 Copyright © 1998 Mitchell Repair Information Company, LLC  
 Wednesday, August 22, 2001 07:08AM

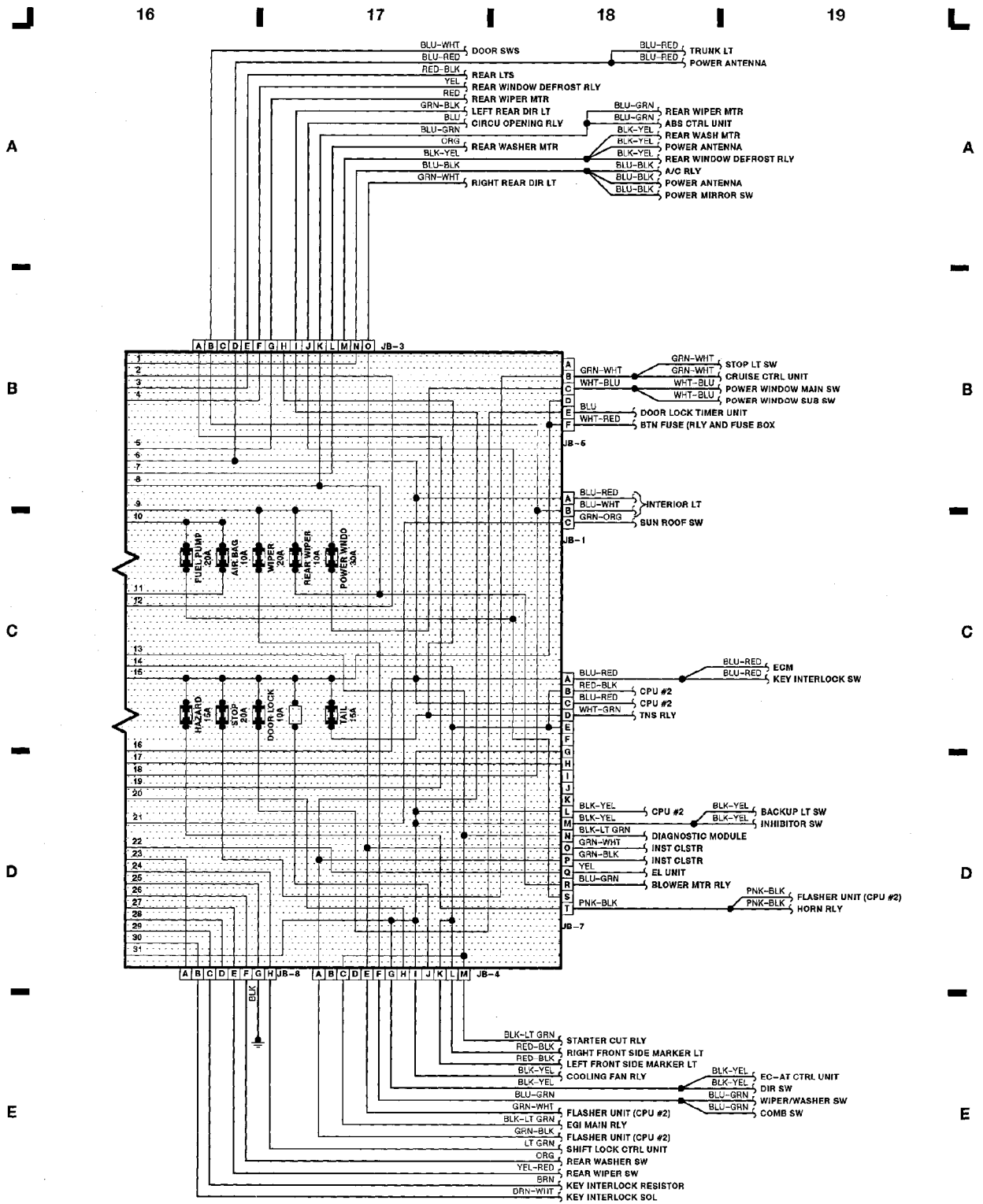

Fig. 5: Joint Box (Cont.) (Grids 16-19)

**WIRING DIAGRAMS**  
**Article Text (p. 8)**  
 1993 Mazda RX7  
 For www.iluvmyrx7.com  
 Copyright © 1998 Mitchell Repair Information Company, LLC  
 Wednesday, August 22, 2001 07:08AM

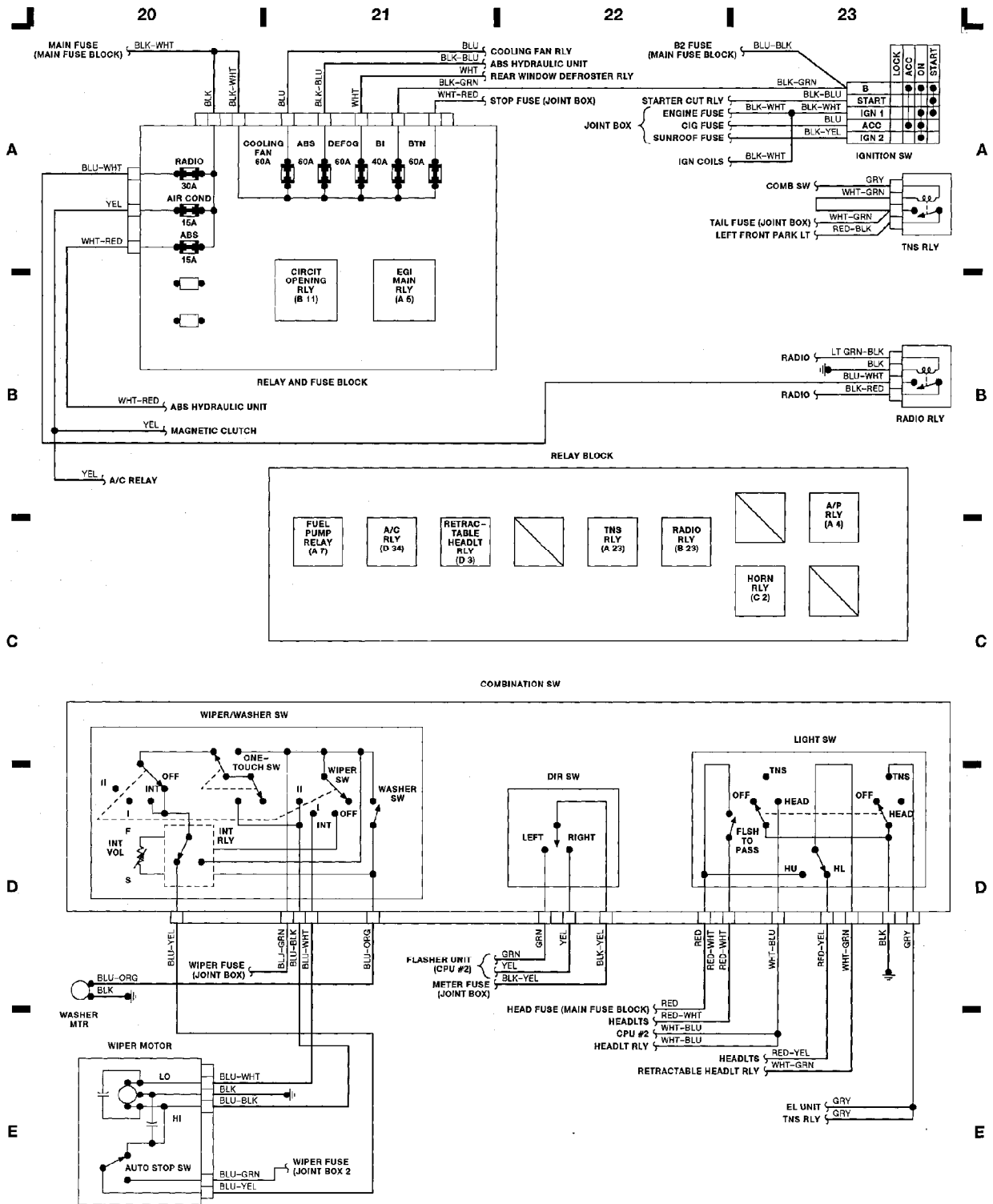

Fig. 6: 94F30754 20 21 22 23  
 Combination Sw, Wiper/Washer Sw (Grids 20-23)

**WIRING DIAGRAMS**  
**Article Text (p. 9)**  
 1993 Mazda RX7  
 For www.iluvmyrx7.com  
 Copyright © 1998 Mitchell Repair Information Company, LLC  
 Wednesday, August 22, 2001 07:08AM

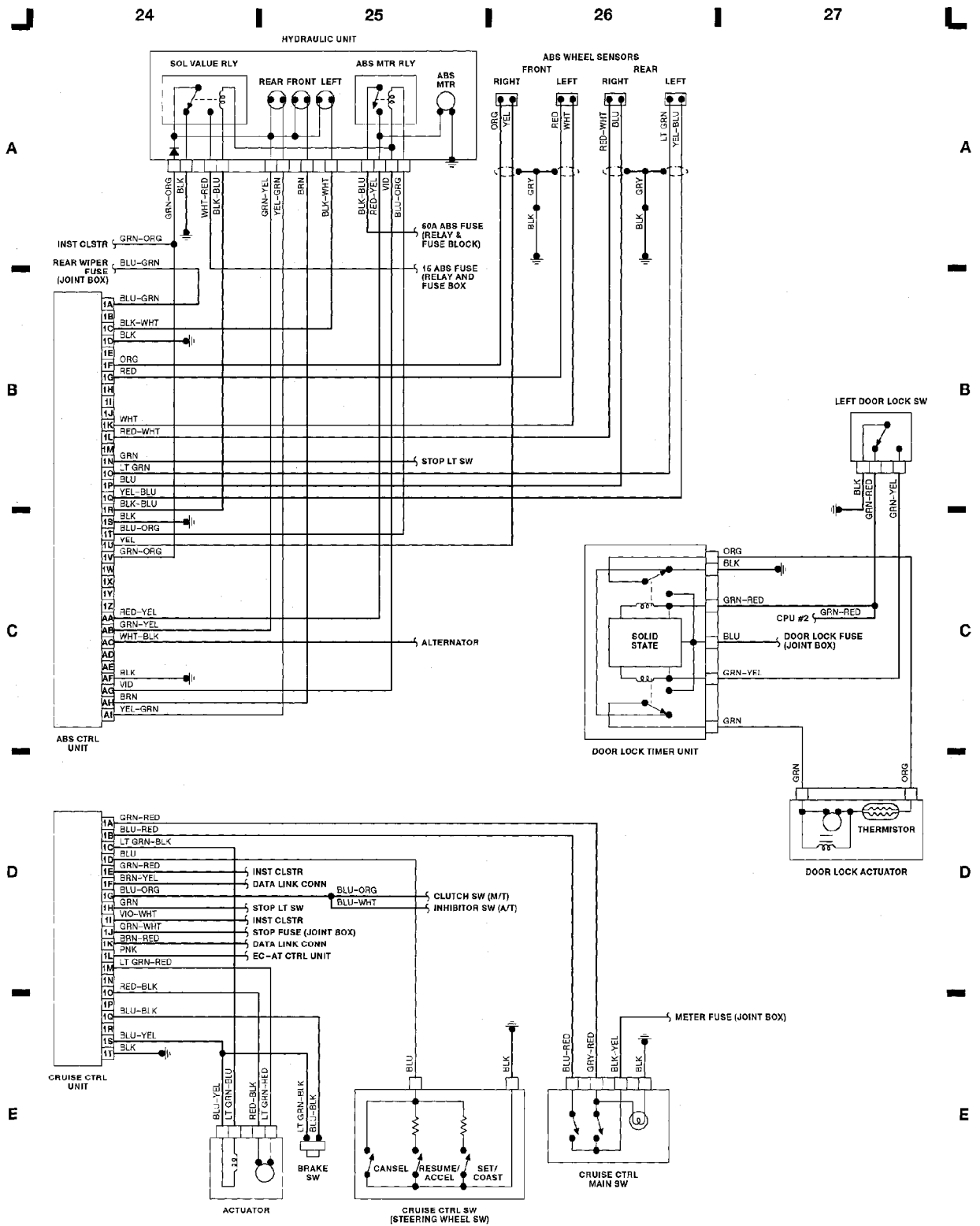

Fig. 7: Cruise Ctrl Unit, Hydraulic Unit (Grids 24-27)

**WIRING DIAGRAMS**  
**Article Text (p. 10)**  
 1993 Mazda RX7  
 For www.iluvmyrx7.com  
 Copyright © 1998 Mitchell Repair Information Company, LLC  
 Wednesday, August 22, 2001 07:08AM

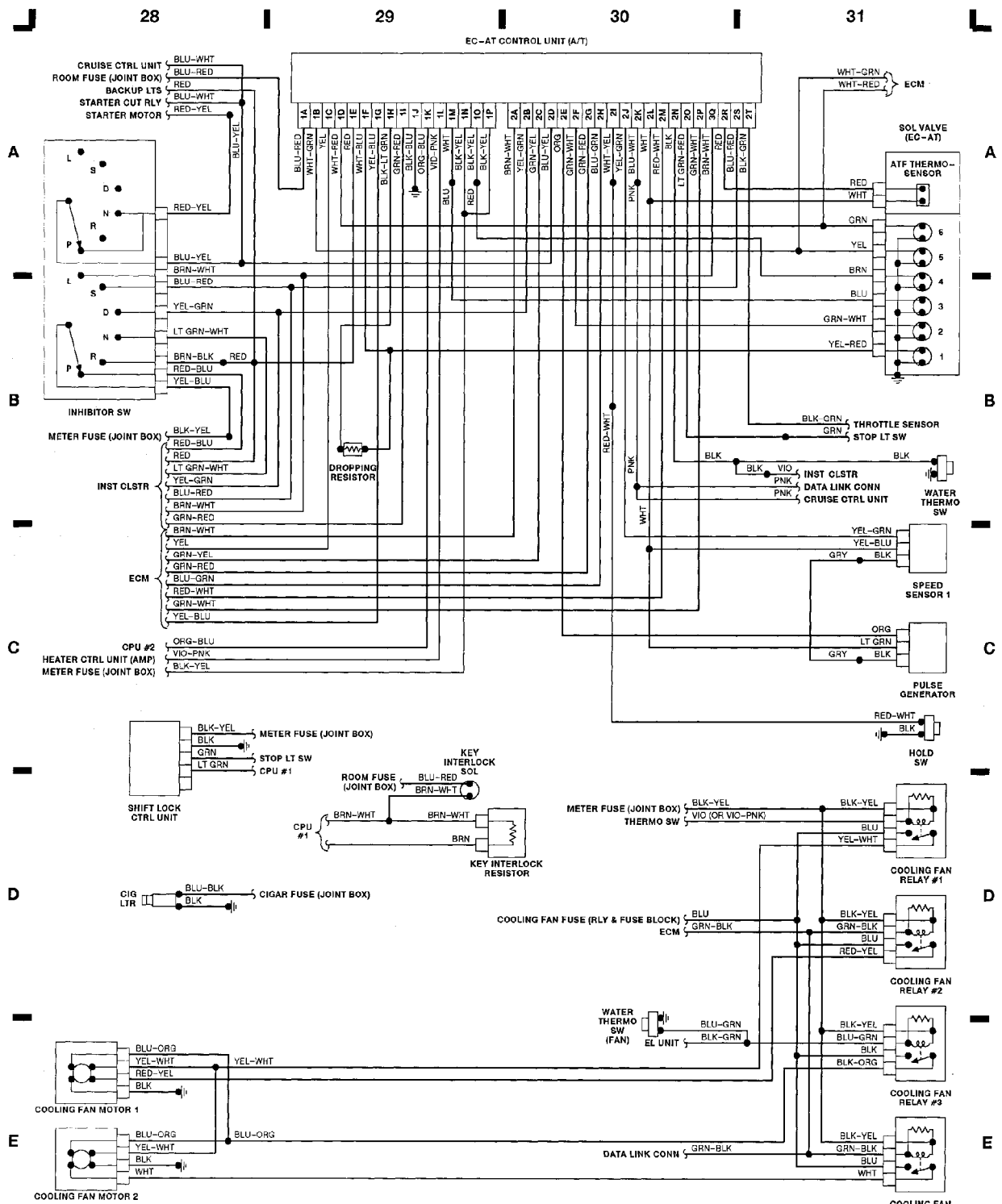

Fig. 8: EC-AT Ctrl Unit, Inhibitor Sw (Grids 28-31)





**WIRING DIAGRAMS**  
**Article Text (p. 12)**  
 1993 Mazda RX7  
 For www.iluvmyrx7.com  
 Copyright © 1998 Mitchell Repair Information Company, LLC  
 Wednesday, August 22, 2001 07:08AM

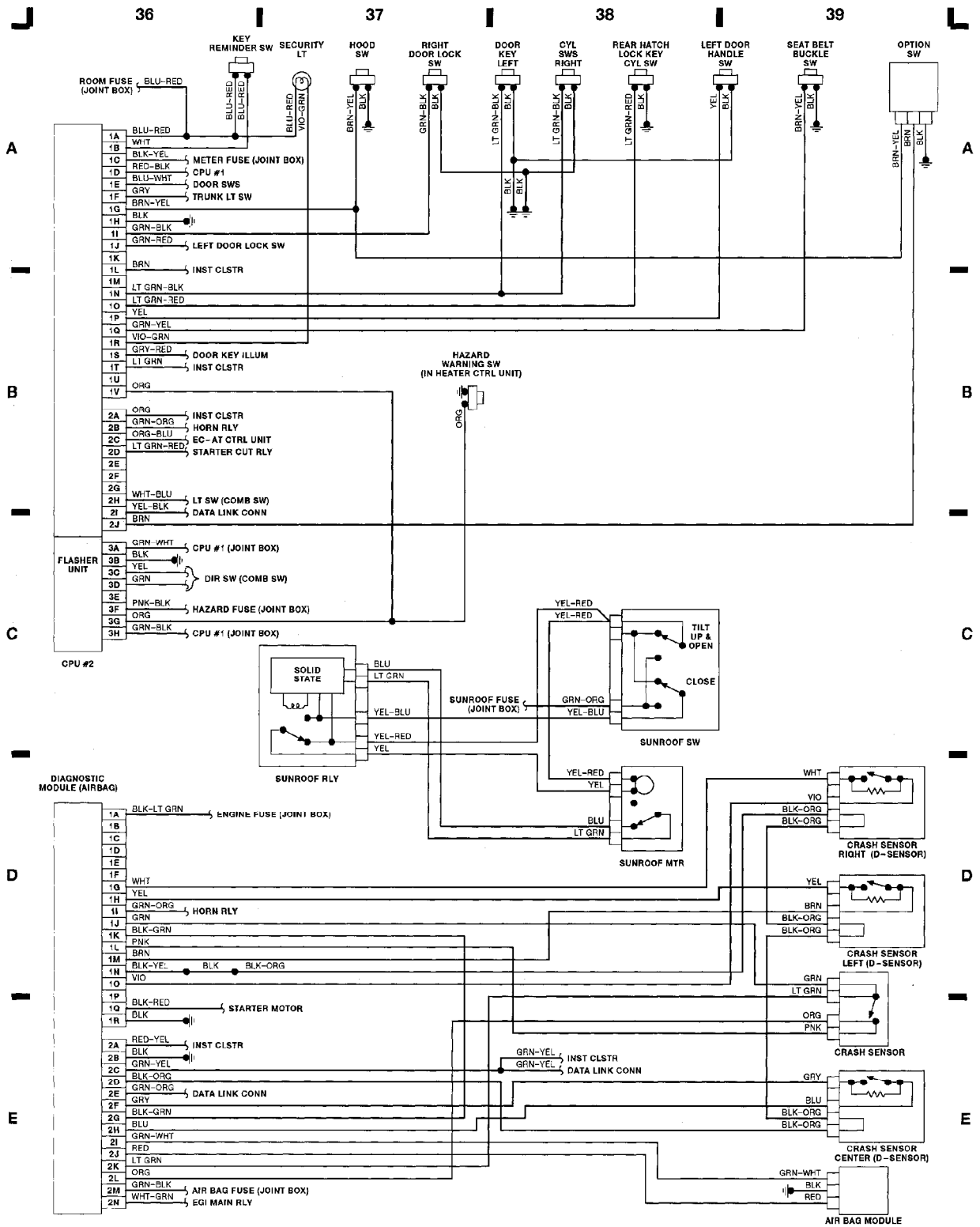

Fig. 10: Diagnostic Module, Flasher Unit (Grids 36-39)

# WIRING DIAGRAMS

Article Text (p. 13)

1993 Mazda RX7

For www.iluvmyrx7.com

Copyright © 1998 Mitchell Repair Information Company, LLC

Wednesday, August 22, 2001 07:08AM

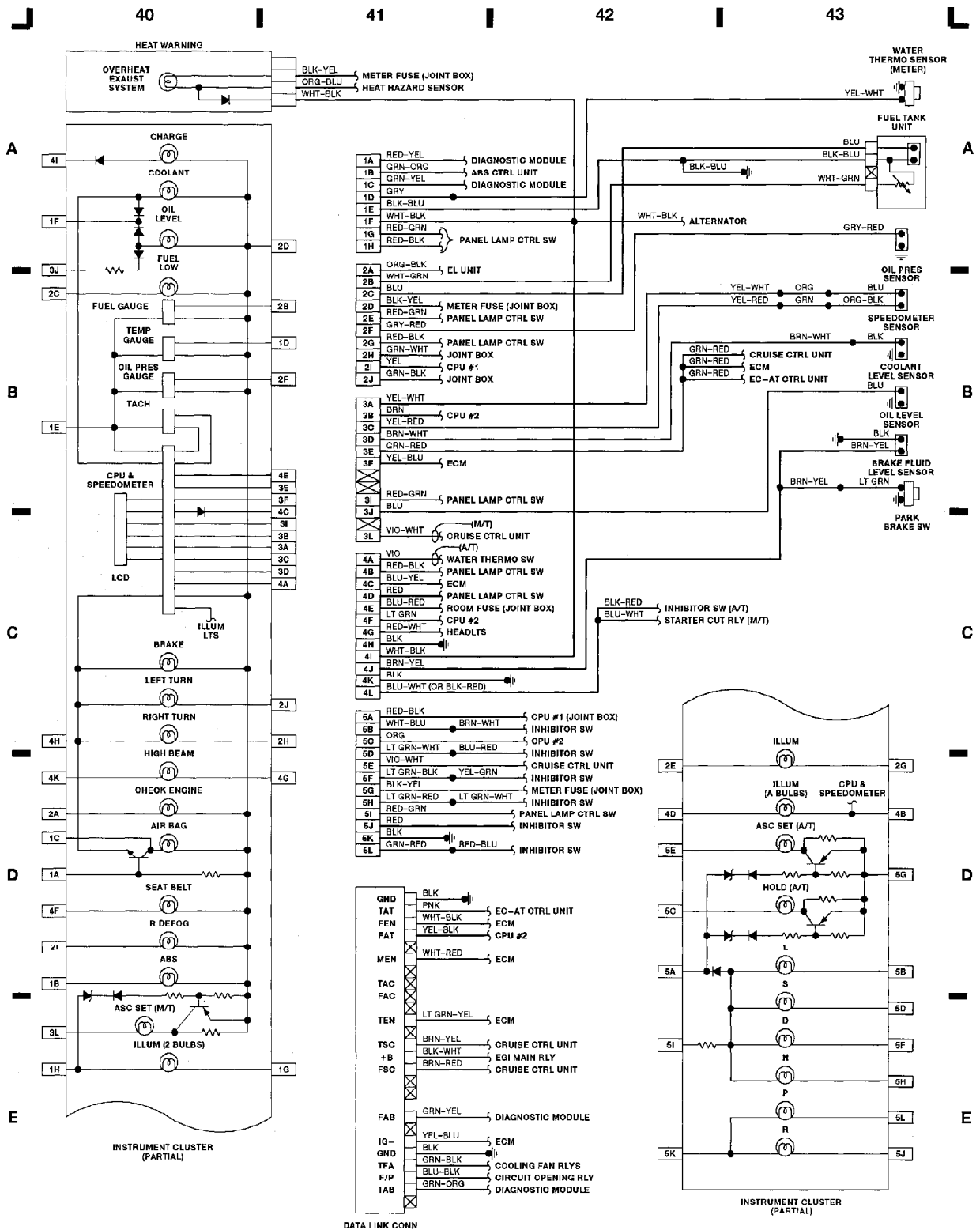

Fig. 11: Instrument Panel (Partial), Heat Warning (Grids 40-43)

**WIRING DIAGRAMS**  
**Article Text (p. 14)**  
 1993 Mazda RX7  
 For www.iluvmyrx7.com  
 Copyright © 1998 Mitchell Repair Information Company, LLC  
 Wednesday, August 22, 2001 07:08AM

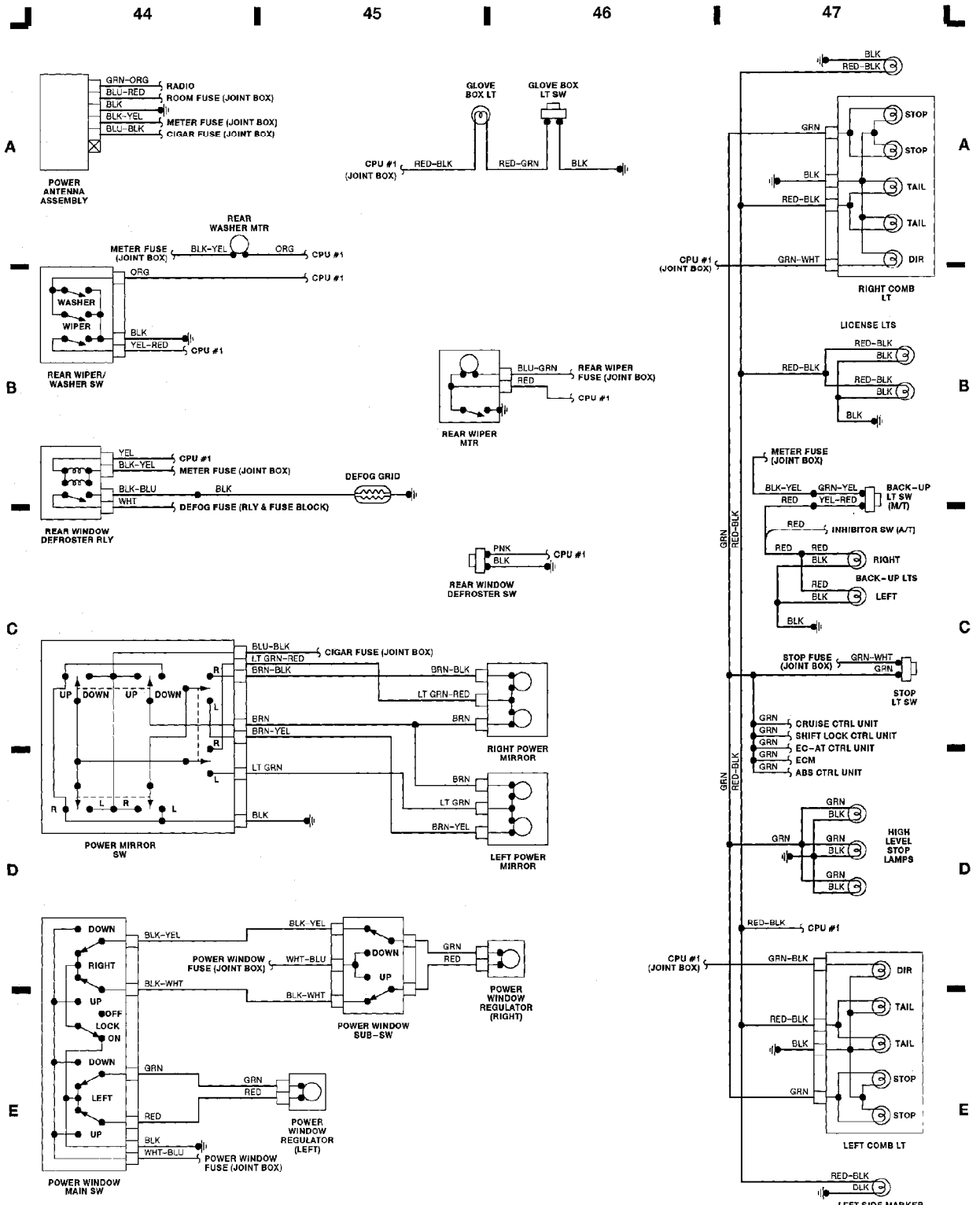

Fig. 12: Power Mirror/Doors/Window, Taillights (Grids 44-47)

END OF ARTICLE