

This file is available for free download at <http://www.iluvmyrx7.com>



While this file is free, the internet space to host it is not. If you receive this file as part of a CD that did not come from iluvmyrx7.com or offered by User ID iluvmyrx7 on eBay, the person selling the CD is making a quick buck off of you and me.

Many thanks to [Kevin Wright](#) for scanning this file.



This document is brought to you through the kind services of

Kevin Wright

krwright@wankel.net

<http://www.wankel.net/~krwright>

who laboriously scanned, post-processed, Distilled, and organized the original 1982 (May 1981 printing) wiring diagram provided by [Michael DeVantier](#) (Thanks!).

There are several ways to get around in the document. I have provided Bookmarks to all the sections and subsections, and thumbnails are also provided in the Thumbnails side bar.

Only a few of the pages in the original document were of the fold-out variety, and only one really needs to be split into multiple documents. This page has been provided in full sheet and segmented versions, as indicated in the Bookmarks. These pages probably should be printed out on 11" x 17" paper if available, but are still readable on 8.5" x 11" paper. You could also print out the segmented versions and attach them together, if so desired (or not. Whatever you want, eh?)

I have also included a label for the spine of a binder, for those who wish to print out all the pages and keep a dead-tree edition handy. ☺

The original document is © 1981 Toyo Kogyo Co., Ltd., and remains so. This version is provided as a service for owners of first generation Mazda RX-7s who are having a devil of a time locating the factory wiring guide for a reasonable price.

If you really want to send me money, email me and I'll tell you where to send it, but it's not necessary. Consider this payback for all the good advice and information gleaned from the various RX-7 email lists!

Subscribe to the Early Mazda Rotaries email list:
Send an email with "subscribe" (without the quotes) to list-request@sa22c.org

See <http://www.dfw-rx7.com> for information on the DFW-RX7 email list.

05/31/02

Mazda RX-7

1982
Wiring Diagram

MAZDA

Mazda RX-7

1982 Wiring Diagram

FOREWORD

This wiring diagram incorporates the wiring schematic for the basic vehicle and its available optional equipment. Actual vehicle wiring may vary slightly depending upon optional equipment and/or local specifications. All information contained in this booklet is based on the latest information available at the time of printing. Toyo Kogyo reserves the right to make changes without previous notice.

This manual is applicable from the following chassis number.

JM1FB331*CO - 600001

Toyo Kogyo Co., Ltd.
HIROSHIMA, JAPAN

SECTION INDEX	
Name	Section
<ul style="list-style-type: none"> ■ How to use this wiring diagram ■ Symbol in this wiring diagram 	O
<ul style="list-style-type: none"> ■ Electric wiring schematic 	W
<ul style="list-style-type: none"> ■ Charging system ■ Starting system 	A
<ul style="list-style-type: none"> ■ Emission control system ■ Ignition system ■ Cruise control system ■ Kick down system (for A/T) ■ Fuel pump 	B
<ul style="list-style-type: none"> ■ Meters & warning lights 	C
<ul style="list-style-type: none"> ■ Front wiper & washer ■ Rear wiper & washer 	D
<ul style="list-style-type: none"> ■ Headlights & illumination lights ■ Headlight cleaner 	E
<ul style="list-style-type: none"> ■ Turn & hazard flasher lights ■ Back-up lights ■ Stop lights ■ License lights ■ Horn ■ Side marker lights ■ Front parking lights ■ Tail lights 	F
<ul style="list-style-type: none"> ■ Stereo & radio ■ Power antenna ■ Heater & air conditioner ■ Rear window defroster 	G
<ul style="list-style-type: none"> ■ Glove box light ■ Seat belt warning system ■ Cigarette lighter ■ Ignition key reminder buzzer ■ Ignition switch light system ■ Interior and spot light ■ Lights off reminder chime system ■ Auto clock ■ Luggage compartment light ■ Glass hatch release system ■ Fuel-door release system 	H
<ul style="list-style-type: none"> ■ Remote control mirror ■ Power window 	I
<ul style="list-style-type: none"> ■ Common connector list 	X

COMPONENT LIST

COMPONENT	SECTION	COMPONENT	SECTION
Actuator solenoid valve.....	B	Fuse block	A ~ J
Air con. solenoid valve.....	B	Fusible link	
Air con. switch	G	Headlight.....	E
Air vent valve	B	Hot start.....	A
Alternator with regulator	A	Main.....	A ~ I
Alternator warning light	C	Retractable headlight motor	E
Auto clock	H	Starting motor.....	A
Back-up light.....	F	Glass hatch release solenoid	H
Back-up light switch.....	F	Glass hatch release switch.....	H
Battery	A ~ I	Glove box light	H
Blower motor	G	Glove box light switch.....	H
Blower motor resistor.....	G	Headlight.....	E
Blower motor switch	G	Headlight cleaner motor	E
Brake fluid level sensor	C	Headlight cleaner switch	E
Brake warning light	C	Heat hazard sensor.....	B
Brake warning light checker	C	High beam indicator light.....	E
Carburetor heater.....	B	Horn.....	F
Chime.....	H	Horn relay.....	F
Choke & check relay	B	Hot start motor.....	A
Choke switch & magnet	B	Hot start relay.....	A
Cigarette lighter	H	Igniter.....	B
Clutch switch.....	B	Ignition coil.....	B
Control processing unit.....	D, F, H	Ignition key reminder switch.....	H
Combination switch		Ignition switch.....	A ~ D, F ~ I
Coast switch	B	Ignition switch light.....	H
Dimmer switch.....	E	Illumination light	E
Hazard switch.....	F	Instrument panel light control.....	E
Horn switch.....	F	Inhibitor switch	A, F
Light switch	E, F, H	Interior & spot light	H
Passing switch	E	Intermittent relay.....	D
Resume switch.....	B	Kick-down solenoid	B
Set switch.....	B	Kick-down switch.....	B
Turn signal switch	F	License light	F
Washer switch	D	Luggage compartment light	H
Wiper switch	D	Luggage compartment light switch.....	H
Coolant level sensor	C	Main amp.....	G
Coolant level unit	C	Magnet clutch	G
Coolant level warning light	C	No. 1 air con. relay	G
Cruise control unit.....	B	No. 1 water temp. switch	B
Cruise control main switch.....	B	No. 2 air con. relay	B
Distributor.....	B	No. 2 water temp. switch	B
Door switch.....	H	Oil pressure gauge	C
Emission control unit	B	Oil pressure gauge unit.....	C
Flasher unit.....	F	Oil level sensor	C
Flost warning temperature switch	G	Oil level warning light	C
Fuel-door release solenoid.....	H	Oscillator	C
Fuel gauge.....	C		
Fuel gauge tank unit	C		
Fuel pump	B		

COMPONENT LIST

COMPONENT	SECTION	COMPONENT	SECTION
Parking brake switch	C	Speaker	G
Parking light	F	Starting motor	A
Power antenna motor	G	Stereo	G
Power antenna switch	G	Stop light switch	F
Power antenna relay	G	Stop switch	B
Power window motor	I	Stop & tail light	F
Power window switch	I	Stop light checker	F
		Switching solenoid valve	B
Radio	G	Sub-zero motor	A
Rear wiper & washer switch	D	Sub-zero sensor	A
Rear window defroster	G		
Rear window defroster indicator light	G	Tachometer	C
Rear window defroster switch	G	Throttle sensor	B
Refrigerant pressure switch	G	Turn signal indicator light	F
Relief solenoid valve	B	Turn & hazard flasher light	F
Remote control mirror	I		
Remote control mirror switch	I	Vacuum control solenoid valve	B
Retractable headlight motor	E	Vehicle speed switch	B
Retractable headlight switch	E	Voltage meter	C
Retractor indicator light	E	Voltage regulator	C
Seat belt switch	H	Washer motor	D
Seat belt warning light	H	Water temp. gauge	C
Shutter valve solenoid valve	B	Water temp. gauge unit	C
Side marker light	F	Wiper motor	D



HOW TO USE THIS WIRING DIAGRAM

The complete electrical system is divided into charging system, ignition system, etc.

Each system is shown on both right and left pages as described below.

When reading the wiring diagram, following should be noted:

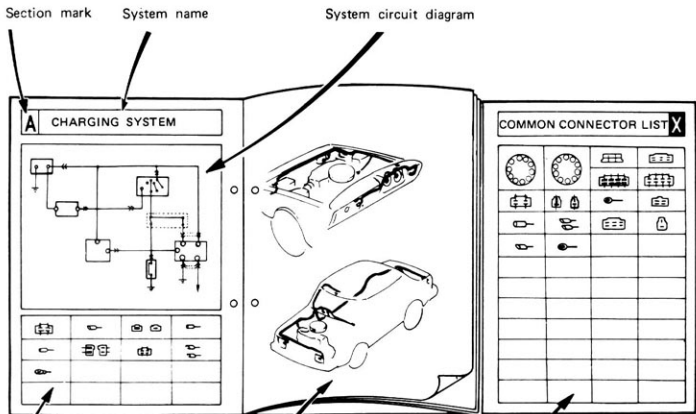

- Connector diagram identifies the exclusive applicable connectors for the circuit.

- Right page illustrates the actual location of each connector and the routing diagram of the harness.

- The last page, "Section X", illustrates common connectors related to each system.

CONNECTOR

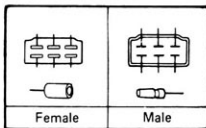

HOW TO USE THIS WIRING DIAGRAM

WIRING COLOR CODE

Wiring color code is indicated with alphabetical letter/s. The first letter indicates the basic color of the wire, and second letter (if any) indicates that the color of the stripe.

CODE	COLOR	CODE	COLOR
B	Black	Lg	Light green
Br	Brown	O	Orange
G	Green	R	Red
L	Blue	Y	Yellow
Lb	Light blue	W	White

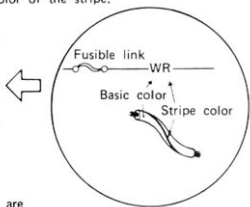

CONNECTOR

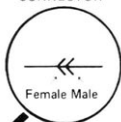

The same fusible link and fuses are indicated on each page.

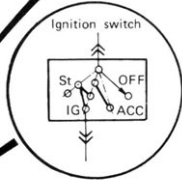
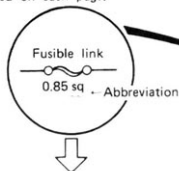

Circuit is shown with the ignition switch off.

ABBREVIATIONS USED IN THIS BOOKLET

Abbr.	Term	Abbr.	Term
St	Start	A	Ampere
IG	Ignition	W	Watt
ACC	Accessory	R	Resistance
AS	Auto stop	Tr	Transistor
INT	Intermittent	M	Motor
Lo	Low	SW	Switch
Mi	Middle	Sq	Square per millimeter
Hi	High		
R.H.	Right hand	A/T	Automatic transmission
L.H.	Left hand		
F.R	Front right	M/T	Manual transmission
F.L	Front left		
R.R	Rear right	NO	Normal opened
R.L	Rear left	NC	Normal closed
V	Volt		

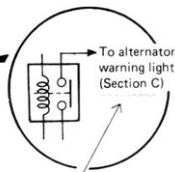
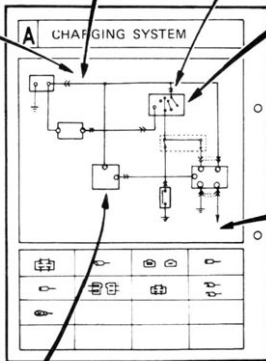

Legend in the parenthesis () indicates the reference section.

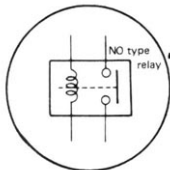









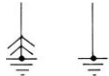
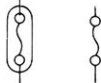



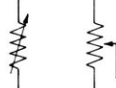

The relays and switches are identified as NC (normal closed), or NO (normal opened), to indicate their normal position when they are not in operation.

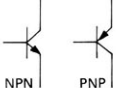
	Relay		Switch	
	NO type relay	NC type relay	NO switch	NC switch
Not in operation				
	Stop	Flow	Stop	Flow
In operation				
	Flow	Stop	Flow	Stop



SYMBOL IN THIS WIRING DIAGRAM

				
<p>BATTERY</p>	<p>HARNESS GROUND BODY</p>	<p>HOLDER FUSE BLOCK</p>	<p>FUSIBLE LINK</p>	<p>MOTOR</p>
				
<p>COIL, SOLENOID</p>	<p>RESISTOR</p>	<p>VARIABLE RESISTOR</p>	<p>THERMISTER</p>	<p>DIODE</p>
				
<p>CONDENSER</p>	<p>TRANSISTOR</p>	<p>PUMP</p>	<p>LIGHT</p>	<p>HORN</p>
				
<p>SPEAKER</p>	<p>CIGARRET LIGHTER</p>	<p>HEATER</p>		

ELECTRICAL WIRING SCHEMATIC

——— CURRENT FROM BATTERY
 - - - - - CURRENT FROM IG TERMINAL OF IGNITION SWITCH
 - · - · - CURRENT FROM ACC TERMINAL OF IGNITION SWITCH
 — · — · — OTHERS

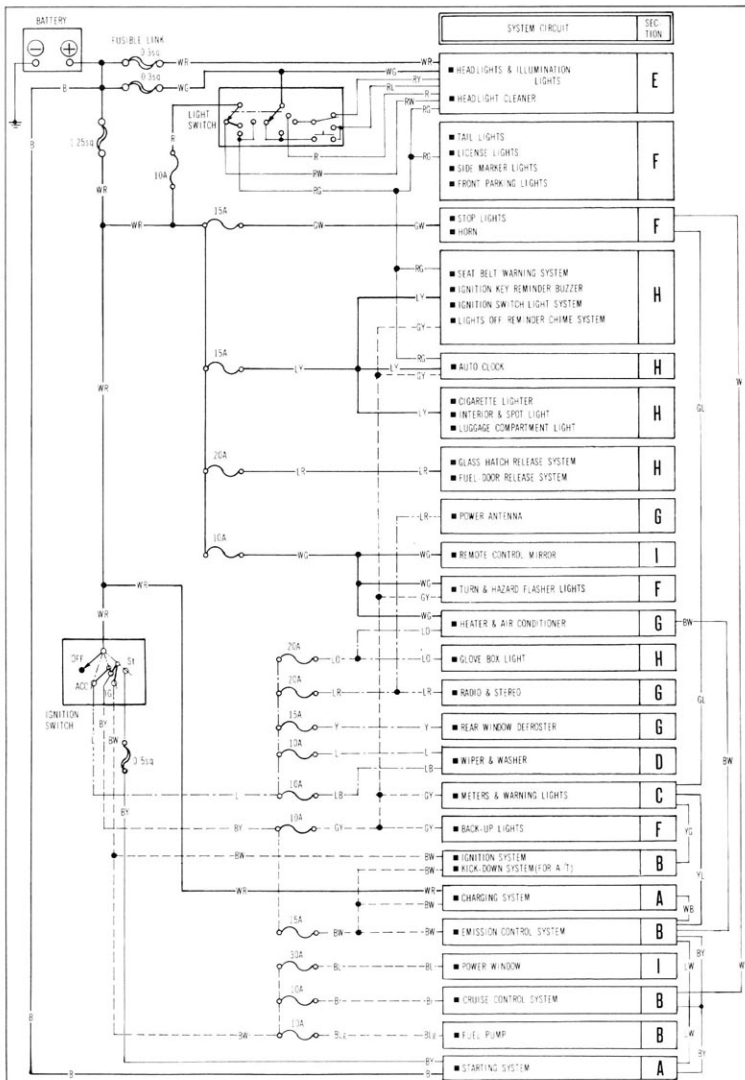

A

■ CHARGING SYSTEM ■ STARTING SYSTEM

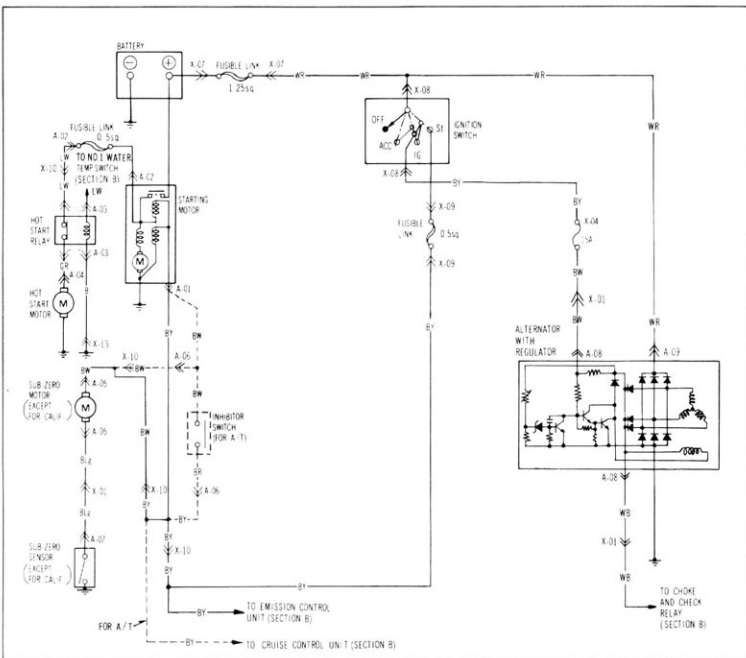

<p>A-03 HOT START RELAY</p>	<p>A-02 FUSIBLE LINK</p>	<p>A-07 SUB-ZERO SENSOR (EXCEPT FOR CALIF.)</p>	<p>A-04 HOT START MOTOR</p>
<p>A-05 SUB-ZERO MOTOR (EXCEPT FOR CALIF.)</p>	<p>A-06 INHIBITOR SWITCH (FOR A/T)</p>	<p>A-08 ALTERNATOR WITH REGULATOR</p>	<p>A-09 TO CHOKE AND CHECK RELAY (SECTION B)</p>
<p>A-01 STARTING MOTOR</p>	<p>A-04 FUSIBLE LINK</p>	<p>A-03 HOT START RELAY</p>	<p>A-04 HOT START MOTOR</p>
<p>A-05 SUB-ZERO MOTOR (EXCEPT FOR CALIF.)</p>	<p>A-06 INHIBITOR SWITCH (FOR A/T)</p>	<p>A-07 SUB-ZERO SENSOR (EXCEPT FOR CALIF.)</p>	<p>A-08 ALTERNATOR WITH REGULATOR</p>

Note: ✕ = Not Used

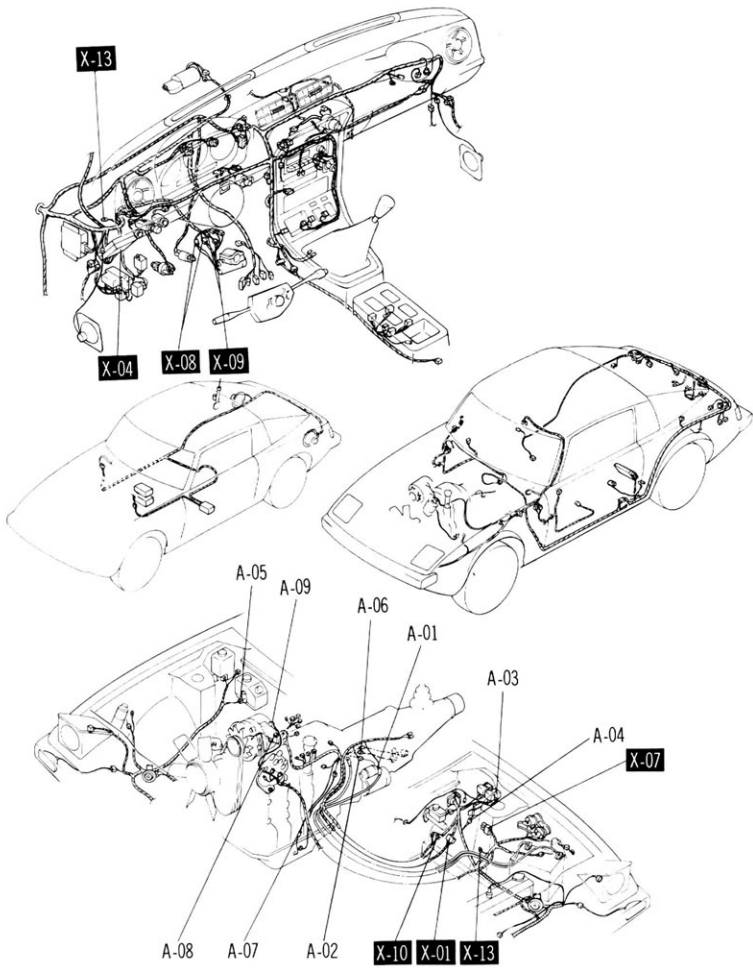

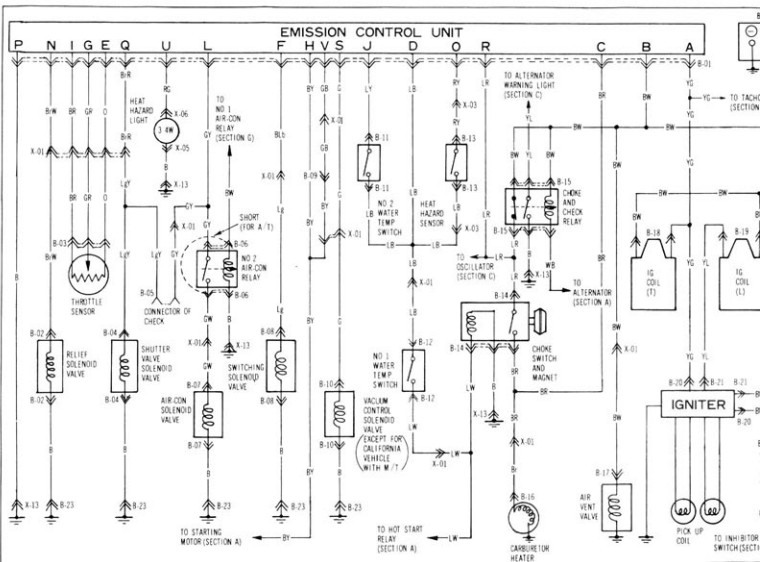
B**■EMISSION CONTROL SYSTEM****■IGNITION SYSTEM****■CRUISE CONTROL****■KICK DOWN SYSTEM(FOR A/T)****■FUEL PUMP**

B-01 EMISSION CONTROL UNIT



B-02 RELIEF SOLENOID VALVE



B-03 THROTTLE SENSOR



B-04 SHUTTER VALVE SOLENOID VALVE



B-05 CONNECTOR OF CHECK



B-09 SHORT CONNECTOR



B-10 VACUUM CONTROL SOLENOID VALVE



B-11 NO. 2 WATER TEMP SWITCH (Rad.)



B-12 NO. 1 WATER TEMP SWITCH (Eng.)



B-16 CARBURETOR HEATER



B-17 AIR VENT VALVE



B-18 IGNITION COIL (I)



B-19 IGNITION COIL (L)



B-20 IGNITER (I)



B-21 IGNITER (L)



B-25 CRUISE CONTROL UNIT



B-26 STOP SWITCH



B-27 CLUTCH SWITCH



B-28 ACTUATOR SOLENOID VALVE



B-29 VEHICLE SPEED SWITCH



B-33 KICK DOWN SOLENOID



IGNITION SYSTEM ■ CRUISE CONTROL SYSTEM

■ FUEL PUMP

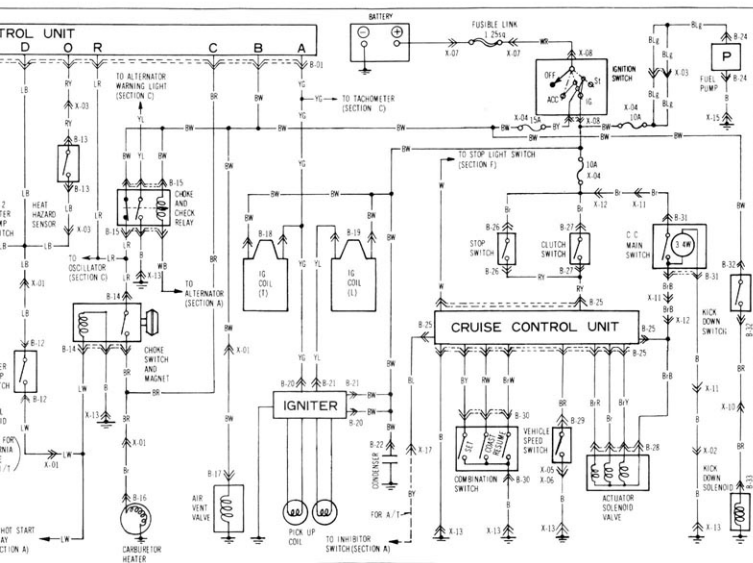

<p>B-03 THRILLER SENSOR</p>	<p>B-04 SHUTTER VALVE SOLENOID VALVE</p>	<p>B-05 CONNECTOR OF CHECK</p>	<p>B-06 NO. 2 AIR-CON RELAY</p>	<p>B-07 AIR-CON SOLENOID VALVE</p>	<p>B-08 SWITCHING SOLENOID VALVE</p>
<p>B-09 VACUUM CONTROL SOLENOID VALVE</p>	<p>B-11 NO. 2 WATER TEMP SWITCH (Rad.)</p>	<p>B-12 NO. 1 WATER TEMP SWITCH (Eng.)</p>	<p>B-13 HEAT HAZARD SENSOR</p>	<p>B-14 CHOKE SWITCH AND MAGNET</p>	<p>B-15 CHOKE AND CHECK RELAY</p>
<p>B-19 IGNITION COIL (L)</p>	<p>B-20 IGNITER (I)</p>	<p>B-21 IGNITER (L)</p>	<p>B-22 CONDENSER</p>	<p>B-23 GROUND</p>	<p>B-24 FUEL PUMP</p>
<p>B-27 CLUTCH SWITCH</p>	<p>B-28 ACTUATOR SOLENOID VALVE</p>	<p>B-29 VEHICLE SPEED SWITCH</p>	<p>B-30 COMBINATION SWITCH</p>	<p>B-31 C.C. MAIN SWITCH</p>	<p>B-32 KICK DOWN SWITCH</p>

B

■EMISSION CONTROL SYSTEM ■IGNITION SYSTEM ■CRUISE CONTROL SYSTEM
 ■KICK DOWN SYSTEM(FOR A/T) ■FUEL PUMP

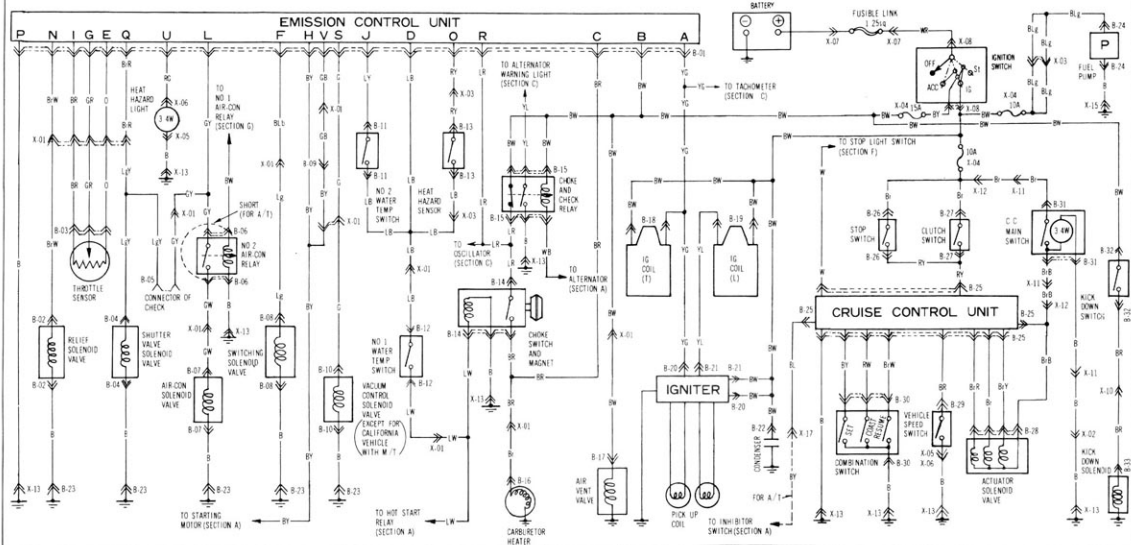

8-01 EMISSION CONTROL UNIT 	8-07 RELIEF SOLENOID VALVE 	8-03 THROTTLE SENSOR 	8-04 SHUTTER VALVE SOLENOID VALVE 	8-05 CONNECTOR OF CHECK 	8-06 NO.2 AIR CON. RELAY (CY) 	8-07 AIR CON. SOLENOID VALVE 	8-08 SWITCHING SOLENOID VALVE
8-09 CARBURETOR HEATER 	8-17 AIR VENT VALVE 	8-10 IGNITION COIL (I) 	8-11 NO.2 WATER TEMP SWITCH (Eq. 4) 	8-12 NO.1 WATER TEMP SWITCH (Eq. 4) 	8-13 HEAT HAZARD SENSOR 	8-14 CHOKE SWITCH AND MAGNET 	8-15 CHOKE AND CHECK RELAY
8-25 CRUISE CONTROL UNIT 	8-26 STOP SWITCH 	8-27 CLUTCH SWITCH 	8-28 ACTUATOR SOLENOID VALVE 	8-29 VEHICLE SPEED SWITCH 	8-30 COMBINATION SWITCH 	8-31 C.C. MAIN SWITCH 	8-32 KICK DOWN SWITCH

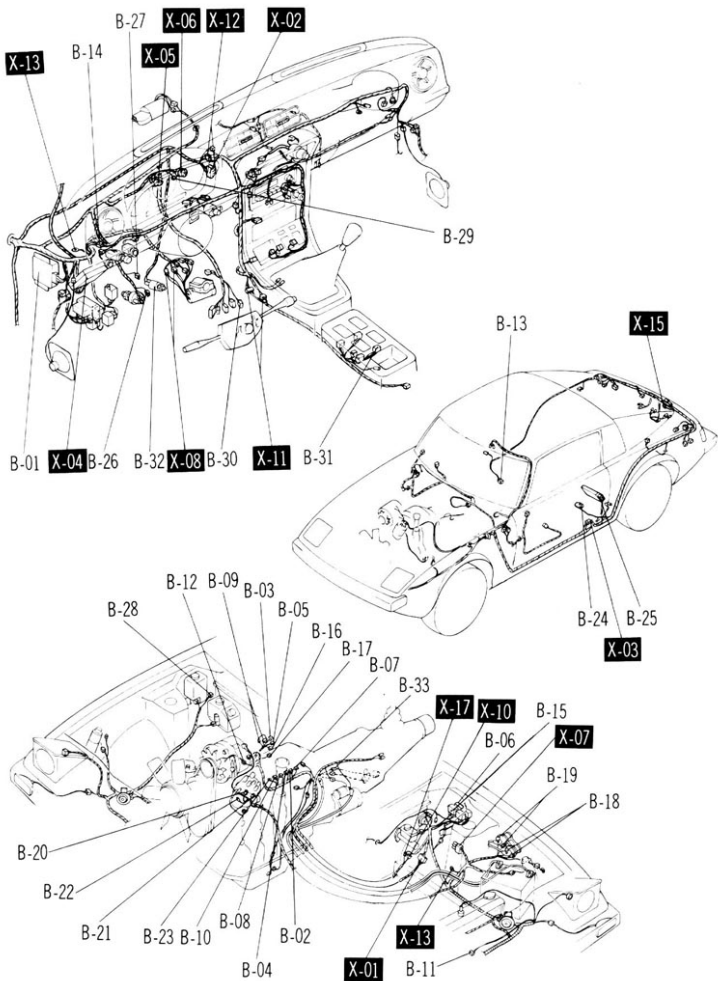

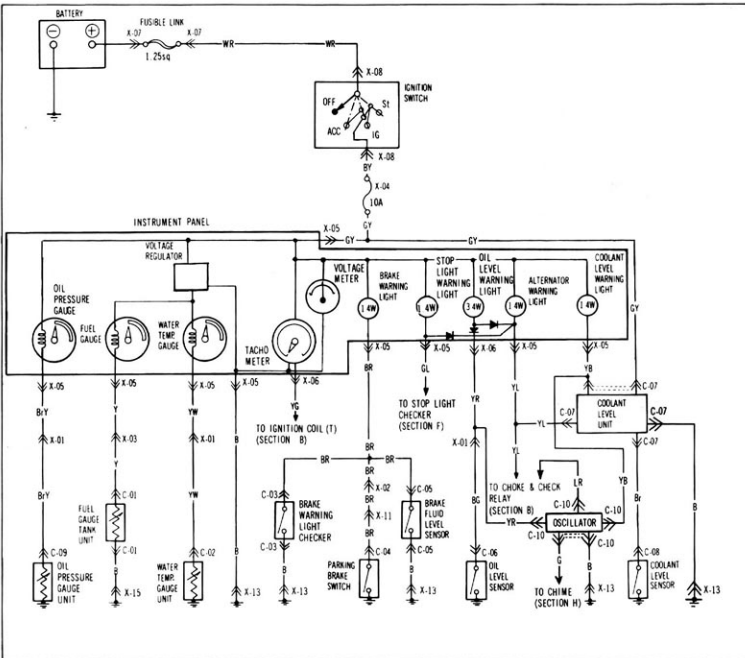

C-01 FUEL GAUGE TANK UNIT



C-02 WATER TEMP GAUGE UNIT



C-03 BRAKE WARNING LIGHT CHECKER



C-04 PARKING BRAKE SWITCH



C-05 BRAKE FLUID LEVEL SENSOR



C-06 OIL LEVEL SENSOR



C-07 COOLANT LEVEL UNIT



C-08 COOLANT LEVEL SENSOR



C-09 OIL PRESSURE GAUGE UNIT



C-10 OSCILLATOR

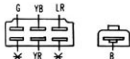

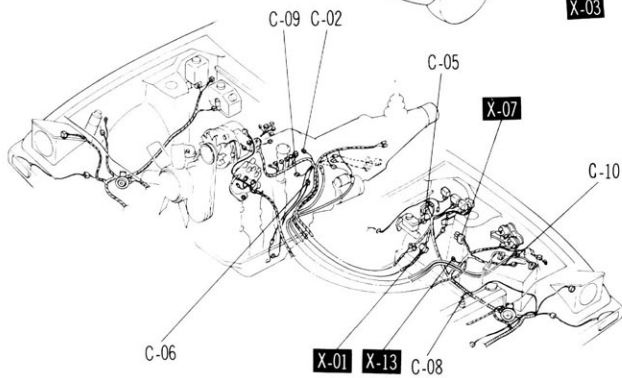
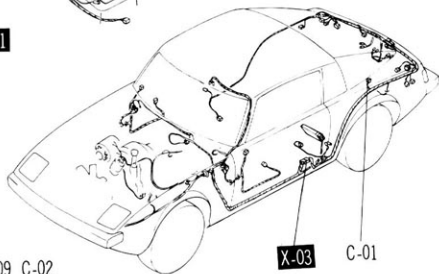
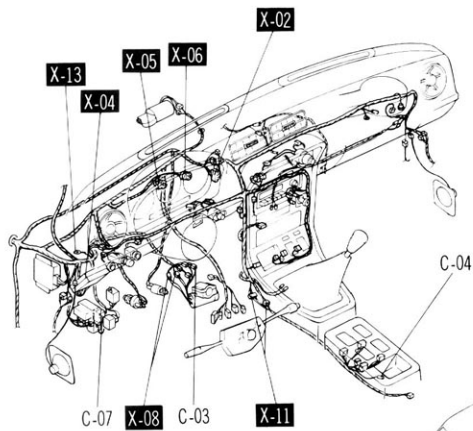

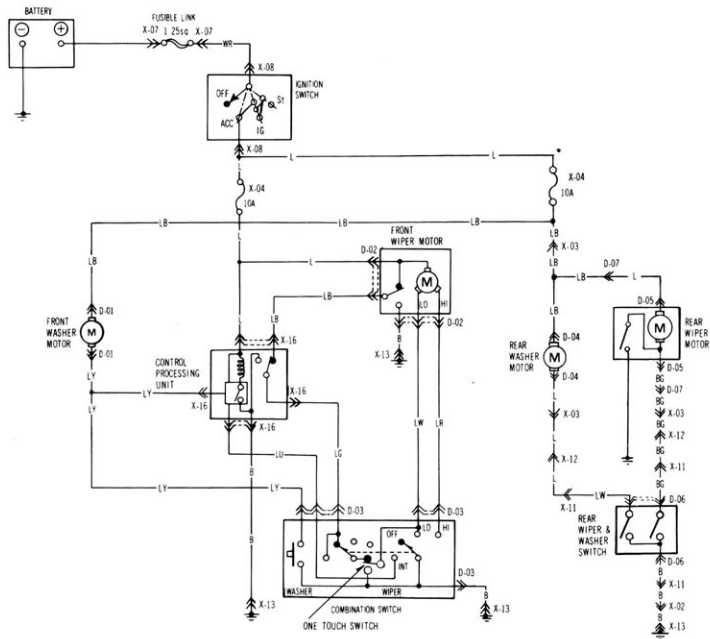
D**■FRONT WIPER & WASHER****■REAR WIPER & WASHER**

D-01 FRONT WASHER MOTOR



D-02 FRONT WIPER MOTOR



D-03 COMBINATION SWITCH



D-04 REAR WASHER MOTOR



D-05 REAR WIPER MOTOR



D-06 REAR WIPER & WASHER SWITCH



D-07 CONNECTOR TO REAR WIPER

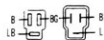

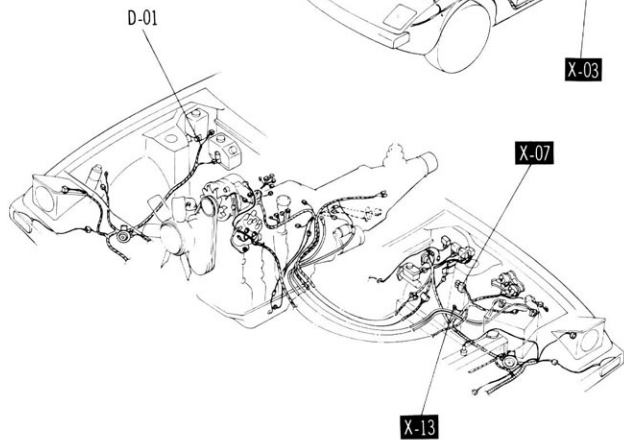
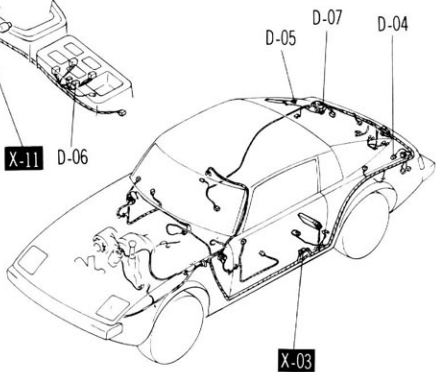
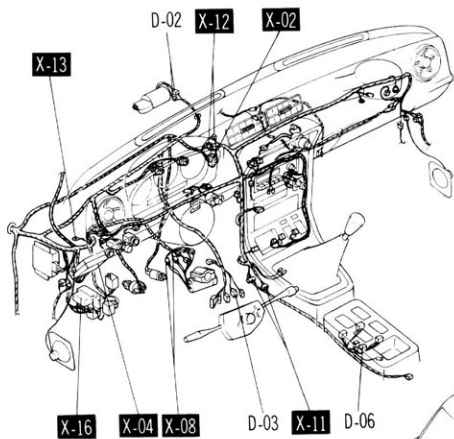

E

■ HEADLIGHTS & ILLUMINATION LIGHTS

■ HEADLIGHT CLEANER

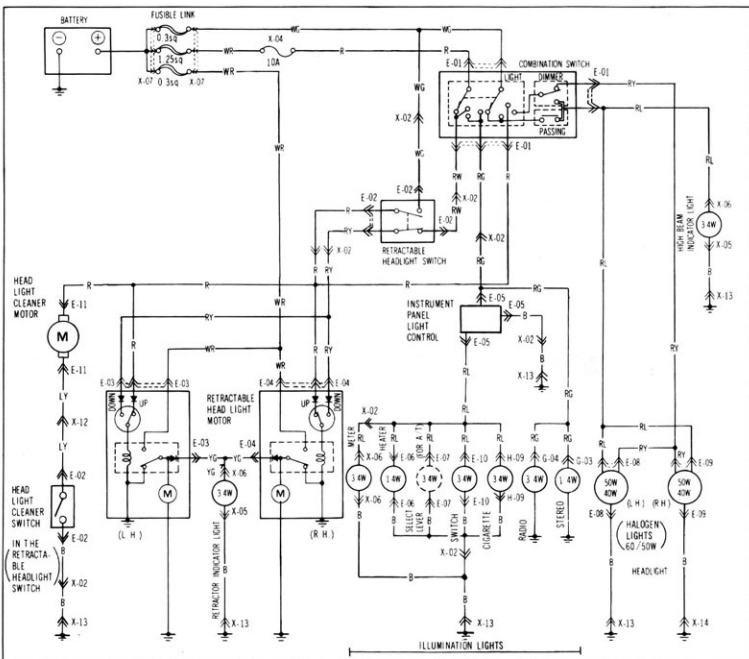

<p>E-01 COMBINATION SWITCH</p>	<p>E-02 RETRACTABLE HEADLIGHT SWITCH</p>	<p>E-03 RETRACTABLE HEADLIGHT MOTOR (L H)</p>	<p>E-04 RETRACTABLE HEADLIGHT MOTOR (R H)</p>
<p>E-05 INSTRUMENT PANEL LIGHT CONTROL</p>	<p>E-06 HEATER ILLUMINATION LIGHT</p>	<p>E-07 SELECT LEVER ILLUMINATION LIGHT (FOR A/T)</p>	<p>E-08 HEADLIGHT (L H)</p>
<p>E-09 HEADLIGHT (R H)</p>	<p>E-10 SWITCH PANEL ILLUMINATION LIGHT</p>	<p>E-11 HEADLIGHT CLEANER MOTOR</p>	

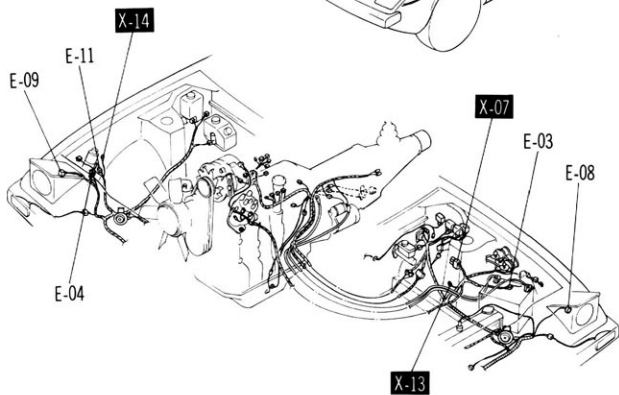
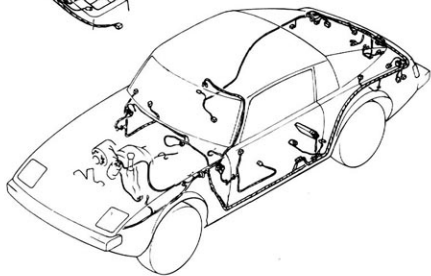
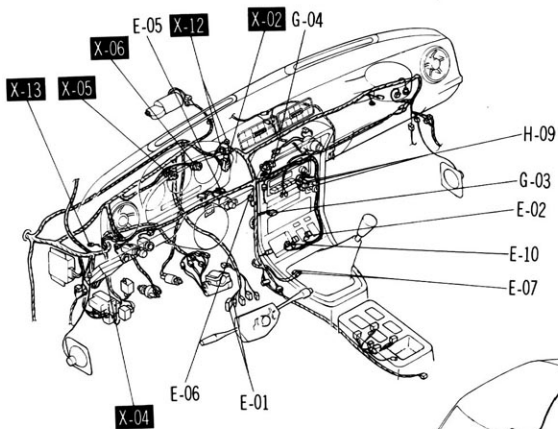

F

■ TURN & HAZARD FLASHER LIGHTS ■ BACK-UP LIGHTS
■ STOP LIGHTS ■ LICENSE LIGHTS ■ HORN
■ SIDE MARKER LIGHTS ■ FRONT PARKING LIGHTS
■ TAIL LIGHTS

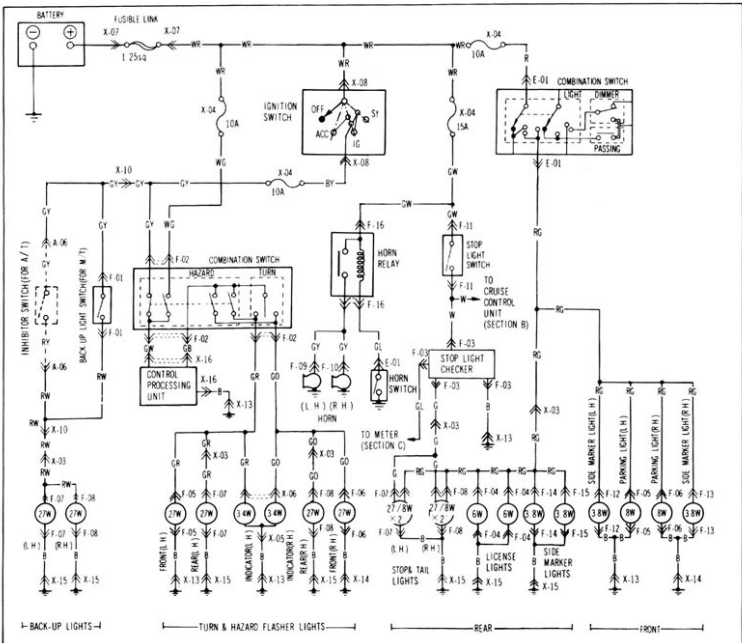

F-01 BACK-UP LIGHT SWITCH 	F-02 COMBINATION SWITCH 	F-03 STOP LIGHT CHECKER 	F-04 LICENSE LIGHT (L H) (R H)
F-05 FRONT TURN & PARKING LIGHT (L H) 	F-06 FRONT TURN & PARKING LIGHT (R H) 	F-07 REAR COMBINATION LIGHT (L H) 	F-08 REAR COMBINATION LIGHT (R H)
F-09 HORN (L H) 	F-10 HORN (R H) 	F-11 STOP LIGHT SWITCH 	F-12 FRONT SIDE MARKER LIGHT (L H)
F-13 FRONT SIDE MARKER LIGHT (R H) 	F-14 REAR SIDE MARKER LIGHT (L H) 	F-15 REAR SIDE MARKER LIGHT (R H) 	F-16 HORN RELAY

Note: * — Not Used

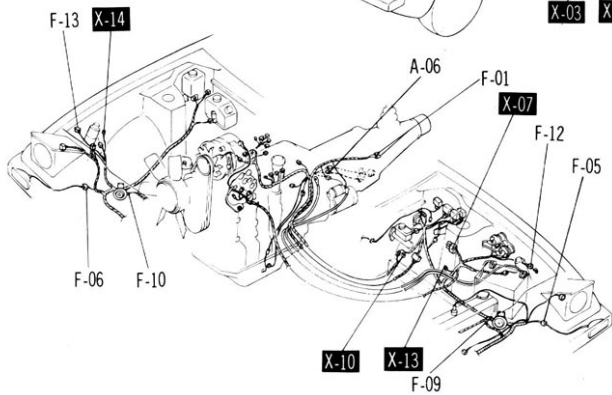
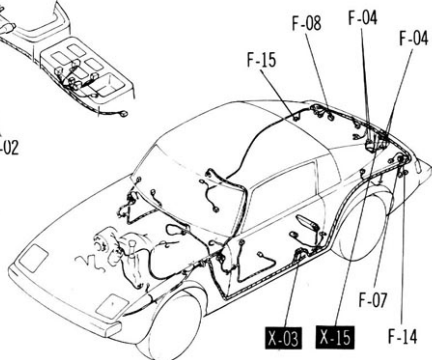
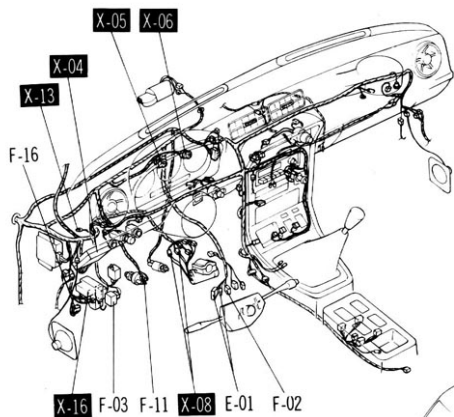

G

■STEREO & RADIO ■POWER ANTENNA
 ■HEATER & AIR CONDITIONER ■REAR WINDOW DEFROSTER

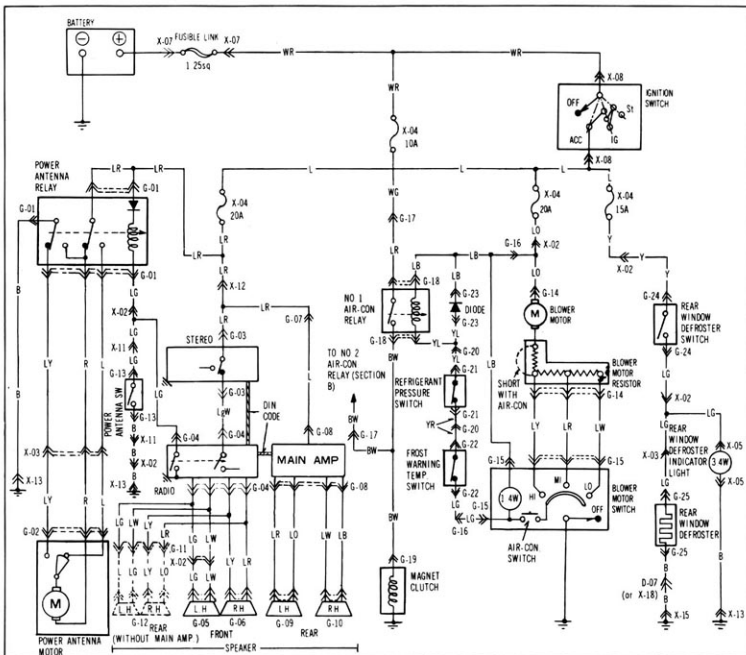

G-01 POWER ANTENNA RELAY 	G-02 POWER ANTENNA MOTOR 	G-03 STEREO 	G-04 RADIO 	G-05 FRONT SPEAKER(L H)
G-06 FRONT SPEAKER(R H) 	G-07 CONNECTOR TO MAIN AMP 	G-08 MAIN AMP 	G-09 REAR SPEAKER(L H) 	G-10 REAR SPEAKER(R H)
G-11 CONNECTOR TO SPEAKER CODE (WITHOUT MAIN AMP) 	G-12 REAR SPEAKER (WITHOUT MAIN AMP) 	G-13 POWER ANTENNA SWITCH (WITHOUT RADIO) 	G-14 BLOWER MOTOR & RESISTOR 	G-15 BLOWER MOTOR SWITCH
G-16 CONNECTOR BETWEEN INPANE AND AIR-CON HARNESS 	G-17 CONNECTOR BETWEEN FRONT AND AIR-CON HARNESS 	G-18 NO 1 AIR-CON RELAY 	G-19 MAGNET CLUTCH 	G-20 CONNECTOR TO REFRIGERANT PRESSURE SWITCH
G-21 REFRIGERANT PRESSURE SWITCH 	G-22 FROST WARNING TEMP SWITCH 	G-23 DIODE 	G-24 REAR WINDOW DEFROSTER SWITCH 	G-25 REAR WINDOW DEFROSTER

Note ✕---Not Used

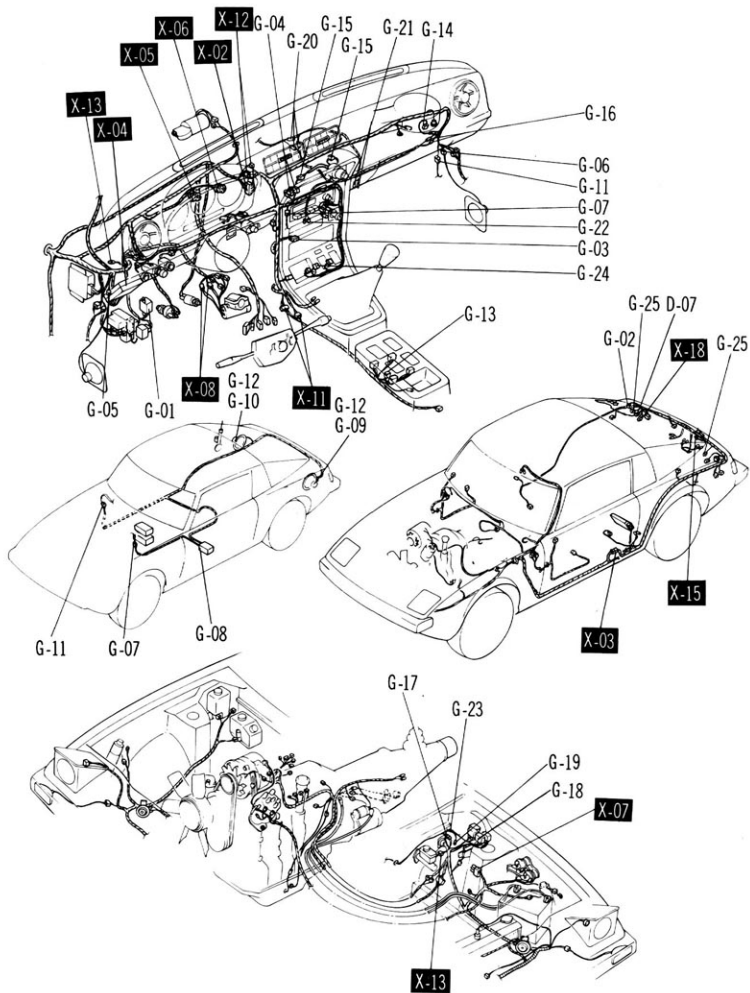

H

- GLOVE BOX LIGHT ■ SEAT BELT WARNING SYSTEM ■ CIGARETTE LIGHTER
- IGNITION KEY REMINDER BUZZER ■ IGNITION SWITCH LIGHT SYSTEM
- INTERIOR AND SPOT LIGHT ■ LIGHTS OFF REMINDER CHIME SYSTEM
- AUTO CLOCK ■ LUGGAGE COMPARTMENT LIGHT
- GLASS HATCH RELEASE SYSTEM ■ FUEL-DOOR RELEASE SYSTEM

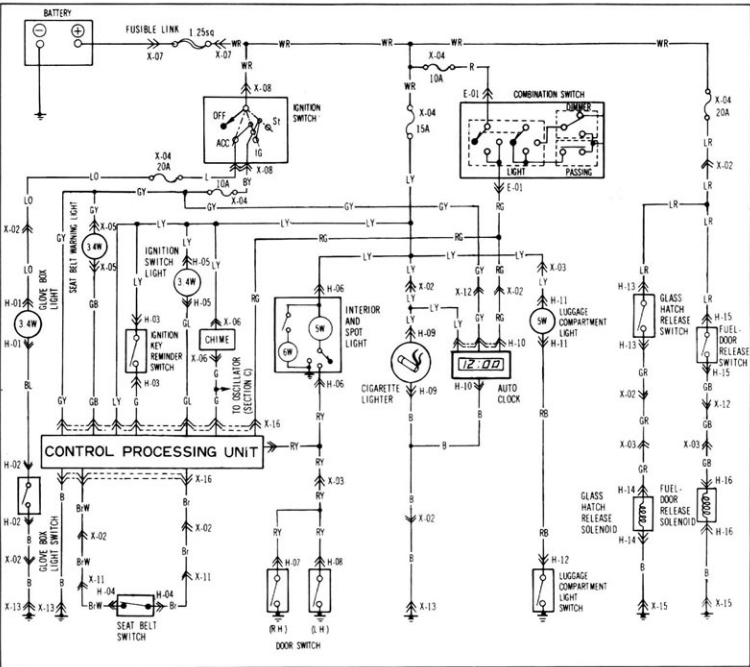

H-01 GLOVE BOX LIGHT 	H-02 GLOVE BOX LIGHT SWITCH 	H-03 IGNITION KEY REMINDER SWITCH 	H-04 SEAT BELT SWITCH
H-05 IGNITION SWITCH LIGHT 	H-06 INTERIOR & SPOT LIGHT 	H-07 DOOR SWITCH(FRONT R.H.) 	H-08 DOOR SWITCH(REAR L.H.)
H-09 CIGARETTE LIGHTER 	H-10 AUTO CLOCK 	H-11 LUGGAGE COMPARTMENT LIGHT 	H-12 LUGGAGE COMPARTMENT LIGHT SWITCH
H-13 GLASS HATCH RELEASE SWITCH 	H-14 GLASS HATCH RELEASE SOLENOID 	H-15 FUEL-DOOR RELEASE SWITCH 	H-16 FUEL-DOOR RELEASE SOLENOID

Note: ✕...Not Used

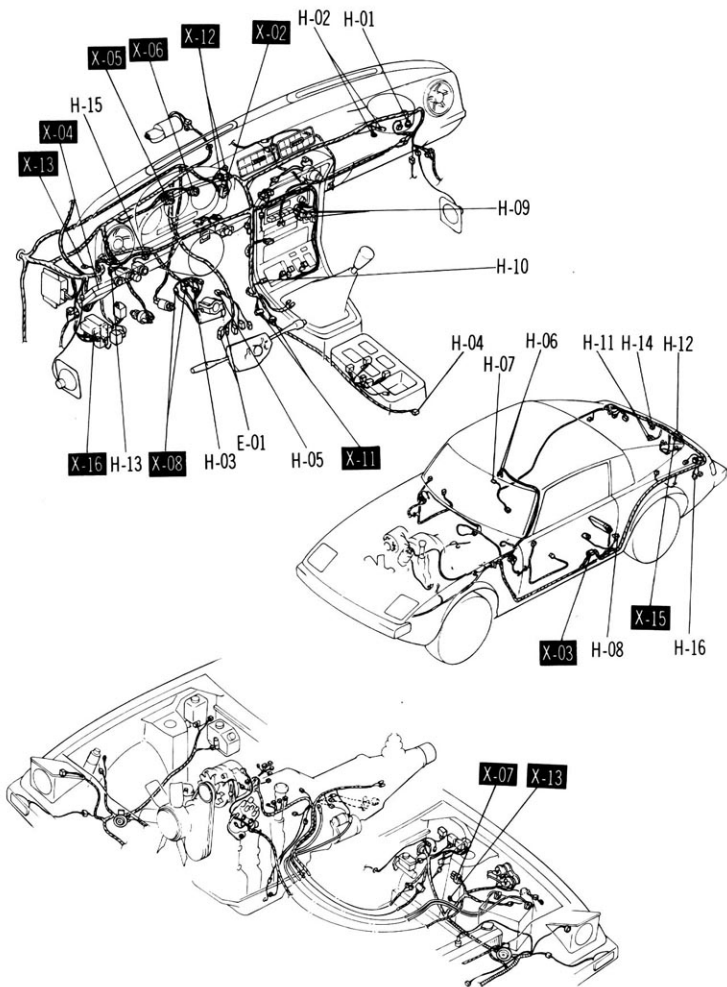

■REMOTE CONTROL MIRROR

■POWER WINDOW

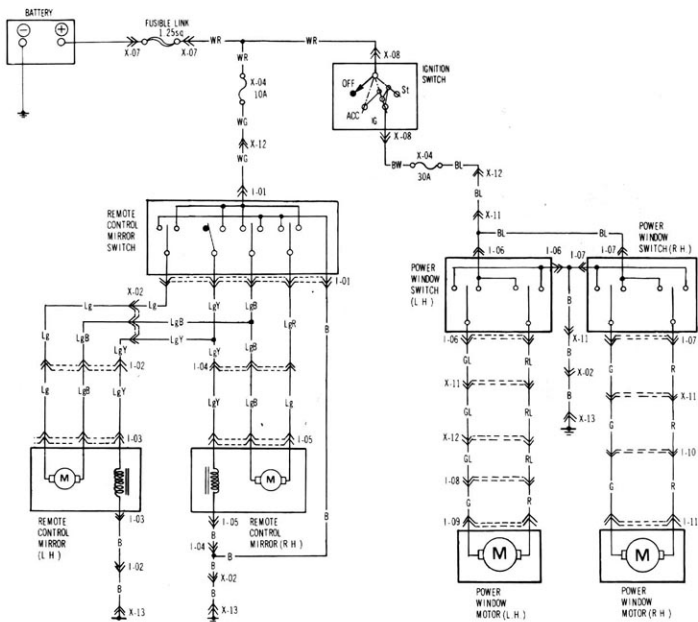

1-01 REMOTE CONTROL MIRROR SWITCH



1-02 CONNECTOR BETWEEN FRONT AND DOOR HARNESS (L H)



1-03 REMOTE CONTROL MIRROR (L H)



1-04 CONNECTOR BETWEEN INPANE AND DOOR HARNESS (R H)



1-05 REMOTE CONTROL MIRROR (R H)



1-06 POWER WINDOW SWITCH (L H)



1-07 POWER WINDOW SWITCH (R H)



1-08 CONNECTOR BETWEEN FRONT AND DOOR HARNESS (L H)



1-09 POWER WINDOW MOTOR (L H)



1-10 CONNECTOR BETWEEN INPANE AND DOOR HARNESS (R H)



1-11 POWER WINDOW MOTOR (R H)



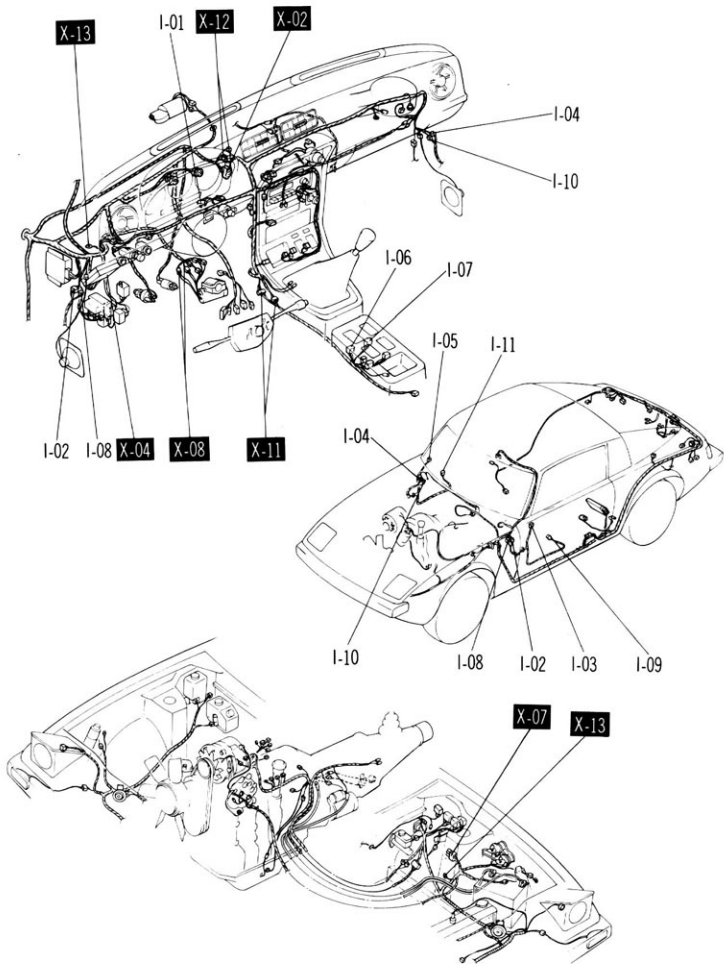

COMMON CONNECTOR LIST

X

X-01 CONNECTOR BETWEEN FRONT AND ENGINE HARNESSSES

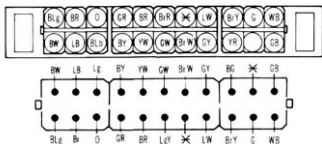

X-02 CONNECTOR BETWEEN FRONT AND INPANE HARNESSSES

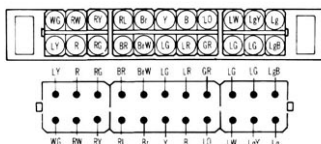

X-03 CONNECTOR BETWEEN FRONT AND REAR HARNESSSES

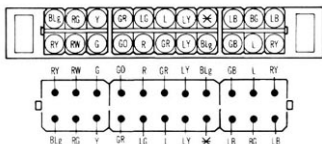

X-04 FUSE BLOCK

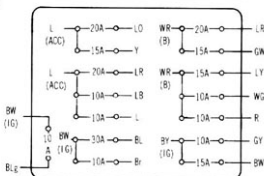

X-05 COMBINATION METER



X-06 COMBINATION METER



X-07 FUSIBLE LINK

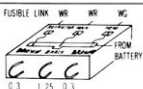

X-08 IGNITION SWITCH



X-09 IGNITION SWITCH



X-10 CONNECTOR TO TRANSMISSION HARNESS

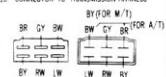

X-11 CONNECTOR BETWEEN INPANE AND PARKING BRAKE HARNESS

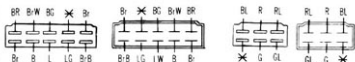

X-12 CONNECTOR BETWEEN FRONT AND INPANE HARNESS

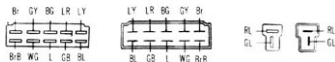

X-13 GROUND



X-14 GROUND



X-15 GROUND



X-16 CONTROL PROCESSING UNIT

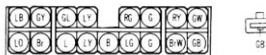

X-17 CONNECTOR TO TRANSMISSION HARNESS (FOR A/T)



X-18 CONNECTOR TO REAR WINDOW DEFROSTER HARNESS (WITHOUT REAR WIPER)



Mazda RX-7 1982 Wiring Diagram

MAZDA