

This file is available for free download at <http://www.iluvmyrx7.com>



While this file is free, the internet space to host it is not. If you receive this file as part of a CD that did not come from iluvmyrx7.com or offered by User ID iluvmyrx7 on eBay, the person selling the CD is making a quick buck off of you and me.

Many thanks to [Kevin Wright](#) for scanning this file.



This document is brought to you through the kind services of

Kevin Wright

krwright@wankel.net

<http://www.wankel.net/~krwright>

who laboriously scanned, post-processed, Distilled, and organized the original 1981 (1980 printing) wiring diagram provided by myself.

There are several ways to get around in the document. I have provided Bookmarks to all the sections and subsections, and thumbnails are also provided in the Thumbnails side bar.

Only a few of the pages in the original document were of the fold-out variety, and only two really needed to be split into multiple documents. These pages have been provided in full sheet and segmented versions, as indicated in the Bookmarks. These pages probably should be printed out on 11" x 17" paper if available, but are still readable on 8.5" x 11" paper. You could also print out the segmented versions and attach them together, if so desired (or not. Whatever you want, eh?)

I have also included a label for the spine of a binder, for those who wish to print out all the pages and keep a dead-tree edition handy. ☺

The original document is © 1980 Toyo Kogyo Co., Ltd., and remains so. This version is provided as a service for owners of first generation Mazda RX-7s who are having a devil of a time locating the factory wiring guide for a reasonable price.

If you really want to send me money, email me and I'll tell you where to send it, but it's not necessary. Consider this payback for all the good advice and information gleaned from the various RX-7 email lists!

Subscribe to the Early Mazda Rotaries email list:
Send an email with "subscribe" (without the quotes) to list-request@sa22c.org

See <http://www.dfw-rx7.com> for information on the DFW-RX7 email list.

05/17/02

Mazda RX-7

1981
Wiring Diagram

mazda

INTRODUCTION

This booklet incorporates the wiring schematic for the basic vehicle and its available optional equipment. Actual vehicle wiring may vary slightly depending upon optional equipment and/or local specifications.

The complete electrical system is divided into charging system, ignition system, etc. Each system is shown on both right and left pages as described below.

All information contained in this booklet is based on the latest information available at the time of printing. Toyo Kogyo reserves the right to make changes without previous notice.

Toyo Kogyo Co., Ltd.

NOTE: When reading the wiring diagram, following should be noted:

Section mark System name System circuit diagram

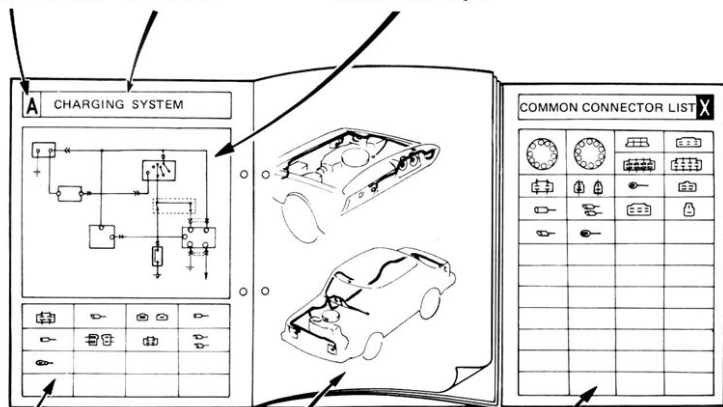

- Connector diagram identifies the exclusive applicable connectors for the circuit.

- Right page illustrates the actual location of each connector and the routing diagram of the harness.

- The last page, "Section X", illustrates common connectors related to each system.

CONNECTOR

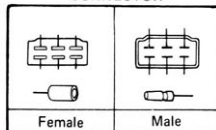

WIRING COLOR CODE

Wiring color code is indicated with alphabetical letter/s. The first letter indicates the basic color of the wire, and second letter (if any) indicates that the color of the stripe.

CODE	COLOR	CODE	COLOR
B	Black	Lg	Light green
Br	Brown	O	Orange
G	Green	R	Red
Gy	Gray	W	White
L	Blue	Y	Yellow
Lb	Light blue		

The same fusible link and fuses are indicated on each page.

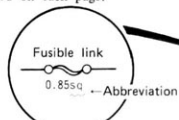

ABBREVIATIONS USED IN THIS BOOKLET

Abbr.	Term	Abbr.	Term
St	Start	A	Ampere
IG	Ignition	W	Watt
ACC	Accessory	R	Resistance
AS	Auto stop	Tr	Transistor
INT	Intermittent	M	Motor
Lo	Low	SW	Switch
Mi	Middle	Sq	Square per millimeter
Hi	High	A/T	Automatic transmission
R.H.	Right hand	M/T	Manual transmission
L.H.	Left hand	NO	Normal opened
F.R	Front right	NC	Normal closed
F.L	Front left		
R.R	Rear right		
R.L	Rear left		
V	Volt		

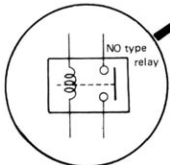

The relays and switches are identified as NC (normal closed), or NO (normal opened), to indicate their normal position when they are not in operation.



	Relay		Switch	
	NO type relay	NC type relay	NO switch	NC switch
Not in operation				
	→ Stop	→ Flow	→ Stop	→ Flow
In operation				
	→ Flow	→ Stop	→ Flow	→ Stop

CONNECTOR

Female Male

Ignition switch

St OFF
IG ACC

Circuit is shown with the ignition switch off.

To alternator warning light (Section C)

Legend in the parenthesis () indicates the reference section.

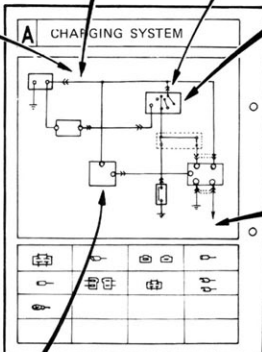

SYMBOL IN THIS WIRING DIAGRAM

BATTERY	GROUND	FUSE	FUSIBLE LINK	MOTOR
COIL, SOLENOID	RESISTOR	VARIABLE RESISTOR	THERMISTER	DIODE
CONDENSER	TRANSISTOR	PUMP	LIGHT	HORN
SPEAKER	CIGARRET LIGHTER	HEATER		

INDEX

CONTENT	SECTION
■ ELECTRICAL WIRING SCHEMATIC	
■ CHARGING SYSTEM	
■ STARTING SYSTEM	A
■ EMISSION CONTROL SYSTEM	
■ CRUISE CONTROL SYSTEM	B
■ IGNITION SYSTEM	
■ KICK-DOWN SYSTEM (FOR A/T)	
■ FUEL PUMP	
■ METERS & WARNING LIGHTS	C
■ WIPER & WASHER	D
■ HEADLIGHTS & ILLUMINATION LIGHTS	E
■ TURN & HAZARD FLASHER LIGHTS	
■ BACK-UP LIGHTS	F
■ STOP & TAIL LIGHTS	
■ LICENSE LIGHTS	
■ HORN	
■ SIDE MARKER LIGHTS	
■ FRONT PARKING LIGHTS	
■ RADIO & STEREO	
■ POWER ANTENNA	G
■ HEATER & AIR CONDITIONER	
■ REAR WINDOW DEFROSTER	
■ GLOVE BOX LIGHT	
■ SEAT BELT WARNING SYSTEM	H
■ CIGARETTE LIGHTER	
■ IGNITION KEY REMINDER BUZZER	
■ IGNITION SWITCH LIGHT SYSTEM	
■ LIGHTS OFF REMINDER CHIME SYSTEM	
■ INTERIOR & SPOT LIGHT	
■ AUTO CLOCK	
■ LUGGAGE COMPARTMENT LIGHT	
■ GLASS HATCH RELEASE SYSTEM	
■ FUEL-DOOR RELEASE SYSTEM	
■ REMOTE CONTROL MIRROR	
■ POWER WINDOW	I
■ COMMON CONNECTOR LIST	X

INDEX

COMPONENT	SECTION	COMPONENT	SECTION
ACTUATOR SOLENOID VALVE	B	IGNITION KEY REMINDER SWITCH	H
AIR CON. SOLENOID VALVE	B	IGNITION SWITCH	A~D, F~I
AIR CON. SWITCH	G	IGNITION SWITCH LIGHT	H
AIR VENT VALVE	B	ILLUMINATION LIGHT	E
ALTERNATOR WITH REGULATOR	A	INSTRUMENT PANEL LIGHT CONTROL	E
ALTERNATOR WARNING LIGHT	C	INHIBITOR SWITCH	A, F
AUTO CLOCK	H	INTERIOR & SPOT LIGHT	H
BACK-UP LIGHT	F	INTERMITTENT RELAY	D
BACK-UP LIGHT SWITCH	F	KICK-DOWN SOLENOID	B
BATTERY	A~1	KICK-DOWN SWITCH	B
BLOWER MOTOR	G	LICENSE LIGHT	F
BLOWER MOTOR RESISTOR	G	LUGGAGE COMPARTMENT LIGHT	H
BLOWER MOTOR SWITCH	G	LUGGAGE COMPARTMENT LIGHT SWITCH	H
BRAKE FLUID LEVEL SENSOR	C	MAIN AMP	G
BRAKE WARNING LIGHT	C	MAGNET CLUTCH	G
BRAKE WARNING LIGHT CHECKER	C	NO. 1 AIR CON. RELAY	G
CARBURETOR HEATER	B	NO. 1 WATER TEMP. SWITCH	B
CHIME	H	NO. 2 AIR CON. RELAY	B
CHOKE & CHECK RELAY	B	NO. 2 WATER TEMP. SWITCH	B
CHOKE SWITCH & MAGNET	B	OIL PRESSURE GAUGE	C
CIGARETTE LIGHTER	H	OIL PRESSURE GAUGE UNIT	C
CLUTCH SWITCH	B	OIL LEVEL SENSOR	C
CONTROL PROCESSING UNIT	D, F, H	OIL LEVEL WARNING LIGHT	C
COMBINATION SWITCH		PARKING BRAKE SWITCH	C
COAST SWITCH	B	PARKING LIGHT	F
DIMMER SWITCH	E	POWER ANTENNA MOTOR	G
HAZARD SWITCH	F	POWER ANTENNA SWITCH	G
HORN SWITCH	F	POWER ANTENNA RELAY	G
LIGHT SWITCH	E, F, H	POWER WINDOW MOTOR	I
PASSING SWITCH	E	POWER WINDOW SWITCH	I
RESUME SWITCH	B	RADIO	G
SET SWITCH	B	REAR WIPER & WASHER SWITCH	E
TURN SIGNAL SWITCH	F	REAR WINDOW DEFROSTER	G
WASHER SWITCH	D	REAR WINDOW DEFROSTER	
WIPER SWITCH	D	INDICATOR LIGHT	G
COOLANT LEVEL SENSOR	C	REAR WINDOW DEFROSTER SWITCH	G
COOLANT LEVEL UNIT	C	REFRIGERANT PRESSURE SWITCH	G
COOLANT LEVEL WARNING LIGHT	C	RELIEF SOLENOID VALVE	B
CRUISE CONTROL UNIT	B	REMOTE CONTROL MIRROR	I
CRUISE CONTROL MAIN SWITCH	B	REMOTE CONTROL MIRROR SWITCH	I
DISTRIBUTOR	B	RETRACTABLE HEADLIGHT MOTOR	E
DOOR SWITCH	H	RETRACTABLE HEADLIGHT SWITCH	E
EMISSION CONTROL UNIT	B	RETRACTOR INDICATOR LIGHT	E
FLASHER UNIT	F	SEAT BELT SWITCH	H
FLOST WARNING TEMPERATURE SWITCH	G	SEAT BELT WARNING LIGHT	H
FUEL-DOOR RELEASE SOLENOID	H	SHUTTER VALVE SOLENOID VALVE	B
FUEL-DOOR RELEASE SWITCH	H	SIDE MARKER LIGHT	F
FUEL GAUGE	C	SPEAKER	G
FUEL GAUGE TANK UNIT	C	SPEED PULSE GENERATOR	B
FUEL PUMP	B	STARTING MOTOR	A
FUSE BLOCK	A~1	STEREO	G
FUSIBLE LINK		STOP LIGHT SWITCH	F
HEADLIGHT	E	STOP SWITCH	B
HOT START	A	STOP & TAIL LIGHT	F
MAIN	A~1	STOP LIGHT CHECKER	F
RETRACTABLE HEADLIGHT MOTOR	E	SWITCHING SOLENOID VALVE	B
STARTING MOTOR	A	SUB-ZERO MOTOR	A
GLASS HATCH RELEASE SOLENOID	H	SUB-ZERO SENSOR	A
GLASS HATCH RELEASE SWITCH	H	TACHOMETER	C
GLOVE BOX LIGHT	H	THROTTLE SENSOR	B
GLOVE BOX LIGHT SWITCH	H	TURN SIGNAL INDICATOR LIGHT	F
HEADLIGHT	E	TURN & HAZARD FLASHER LIGHT	F
HEADLIGHT CLEANER MOTOR	E	VACUUM CONTROL SOLENOID VALVE	B
HEADLIGHT CLEANER SWITCH	E	VOLTAGE METER	C
HEAT HAZARD SENSOR	B	VOLTAGE REGULATOR	C
HIGH BEAM INDICATOR LIGHT	E	WASHER MOTOR	D
HORN	F	WATER TEMP. GAUGE	C
HORN RELAY	F	WATER TEMP. GAUGE UNIT	C
HOT START MOTOR	A	WIPER MOTOR	D
HOT START RELAY	A		
IGNITER	B		
IGNITION COIL	B		

ELECTRICAL WIRING SCHEMATIC

- CURRENT FROM BATTERY
- - - - - CURRENT FROM IG TERMINAL OF IGNITION SWITCH
- · - · - · CURRENT FROM ACC. TERMINAL OF IGNITION SWITCH
- OTHERS

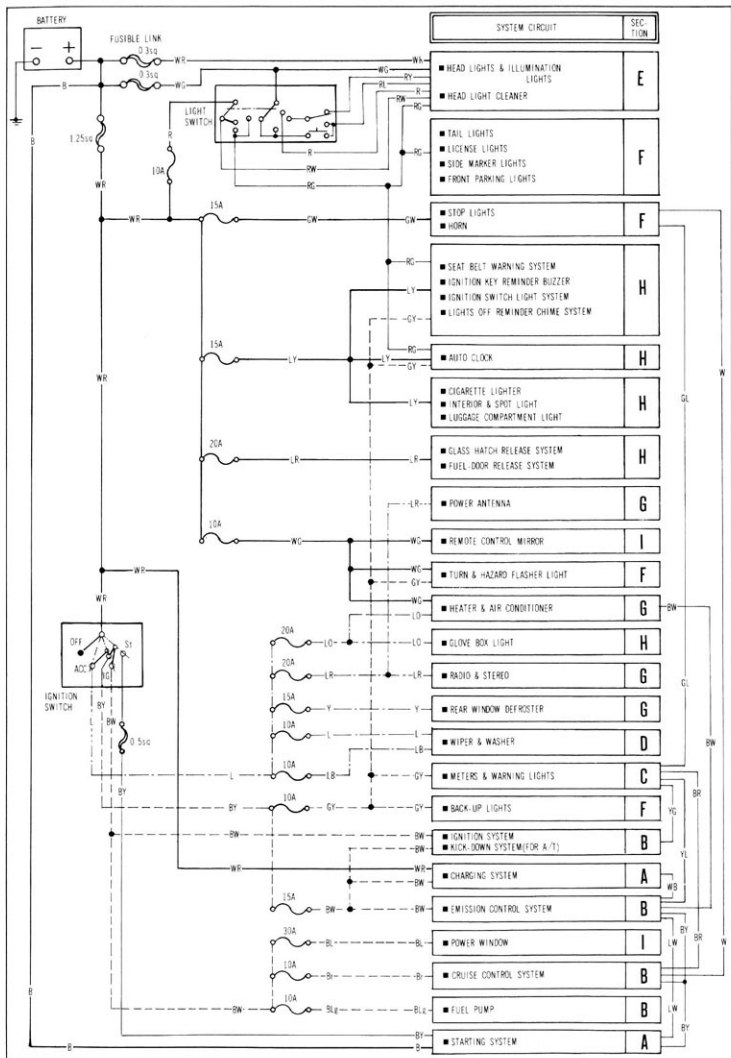

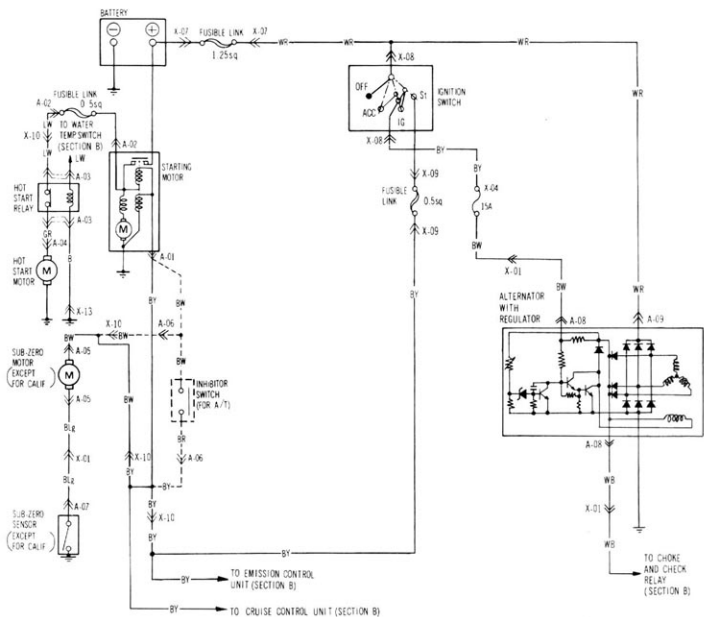
A**■CHARGING SYSTEM ■STARTING SYSTEM**

A-01 STARTING MOTOR



A-02 FUSIBLE LINK



A-03 HOT START RELAY



A-04 HOT START MOTOR



A-05 SUB-ZERO MOTOR (EXCEPT FOR CALIF.)



A-06 INHIBITOR SWITCH (FOR A/T)



A-07 SUB-ZERO SENSOR (EXCEPT FOR CALIF.)



A-08 ALTERNATOR WITH REGULATOR



A-09 ALTERNATOR WITH REGULATOR



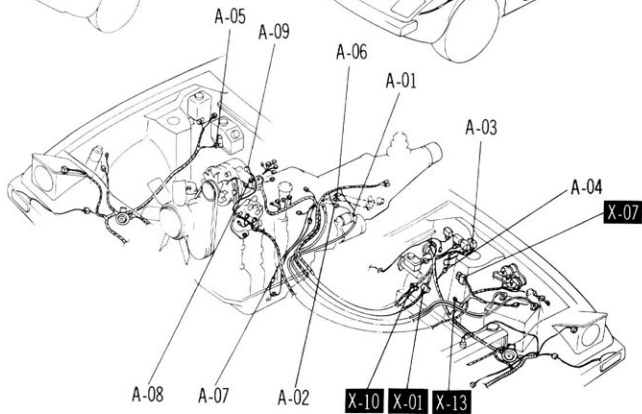
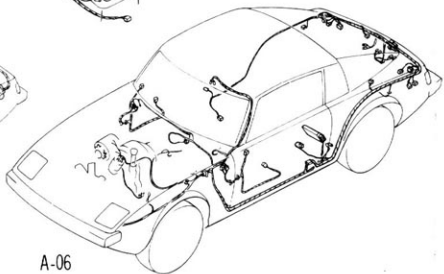
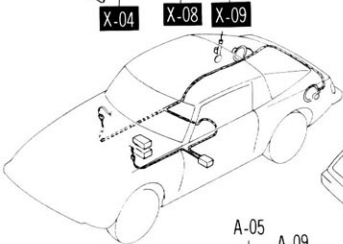
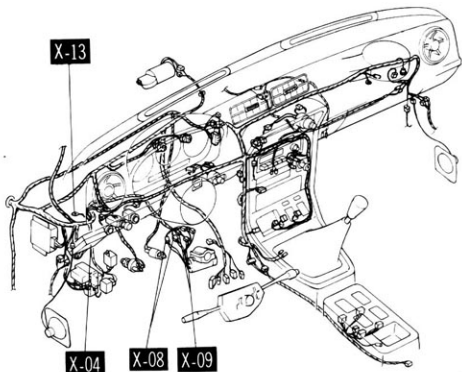

B

■EMISSION CONTROL SYSTEM ■IGNITION SYSTEM ■CRUISE CONTROL
 ■KICK DOWN SYSTEM(FOR A/T) ■FUEL PUMP

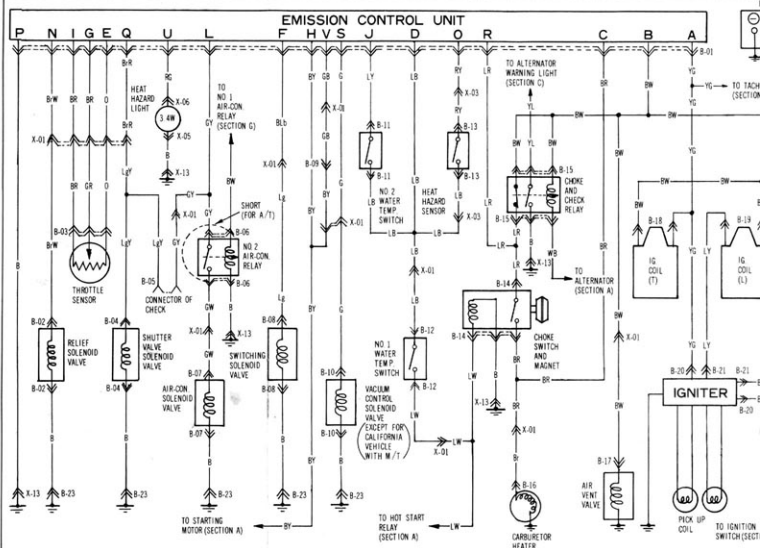

B-01 EMISSION CONTROL UNIT

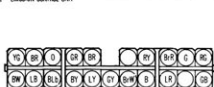

B-02 RELIEF SOLENOID VALVE



B-03 THROTTLE SENSOR



B-04 SHUTTER VALVE SOLENOID VALVE



B-05 CONNECTOR OF CHECK



B-06 SHORT CONNECTOR



B-10 VACUUM CONTROL SOLENOID VALVE



B-11 NO. 2 WATER TEMP. SWITCH (Red.)



B-12 NO. 1 WATER TEMP. SWITCH (Eng.)



B-16 CARBURETOR HEATER



B-17 AIR VENT VALVE



B-18 IGNITION COIL (T)



B-19 IGNITION COIL (L)



B-20 IGNITER (T)



B-21 IGNITER (L)



B-25 CRUISE CONTROL UNIT



B-26 STOP SWITCH



B-27 CLUTCH SWITCH



B-28 ACTUATOR SOLENOID VALVE



B-29 SPEED PULSE GENERATOR



B-33 KICK DOWN SOLENOID



IGNITION SYSTEM ■ CRUISE CONTROL SYSTEM

■ FUEL PUMP

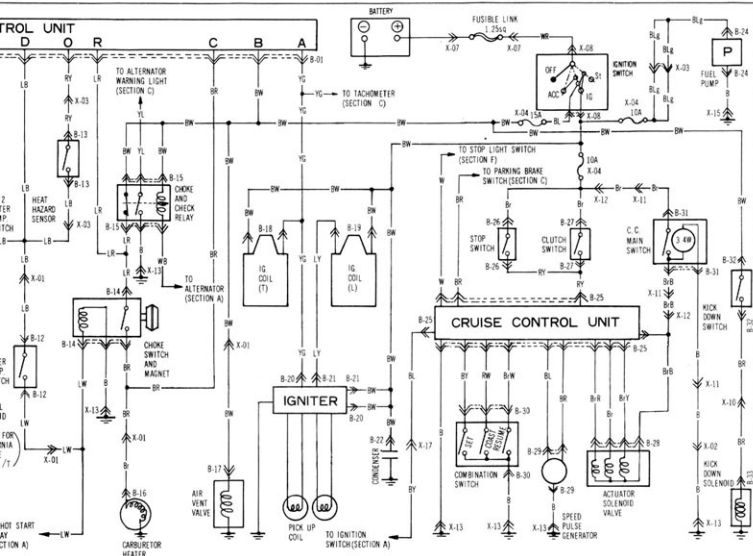

B-03 THROTTLE SENSOR 	B-04 SHUTTER VALVE SOLENOID VALVE 	B-05 CONNECTOR OF CHECK 	B-06 NO 2 AIR-CON. RELAY 	B-07 AIR-CON. SOLENOID VALVE 	B-08 SWITCHING SOLENOID VALVE
B-10 VACUUM CONTROL SOLENOID VALVE 	B-11 NO. 2 WATER TEMP SWITCH (Red.) 	B-12 NO. 1 WATER TEMP SWITCH (Eng.) 	B-13 HEAT HAZARD SENSOR 	B-14 CHOKE SWITCH AND MAGNET 	B-15 CHOKE AND CHECK RELAY
B-19 IGNITION COIL (L) 	B-20 IGNITER (T) 	B-21 IGNITER (L) 	B-22 CONDENSER 	B-23 GROUND 	B-24 FUEL PUMP
B-27 CLUTCH SWITCH 	B-28 ACTUATOR SOLENOID VALVE 	B-29 SPEED PULSE GENERATOR 	B-30 COMBINATION SWITCH 	B-31 C.C. MAIN SWITCH 	B-32 KICK DOWN SWITCH

B



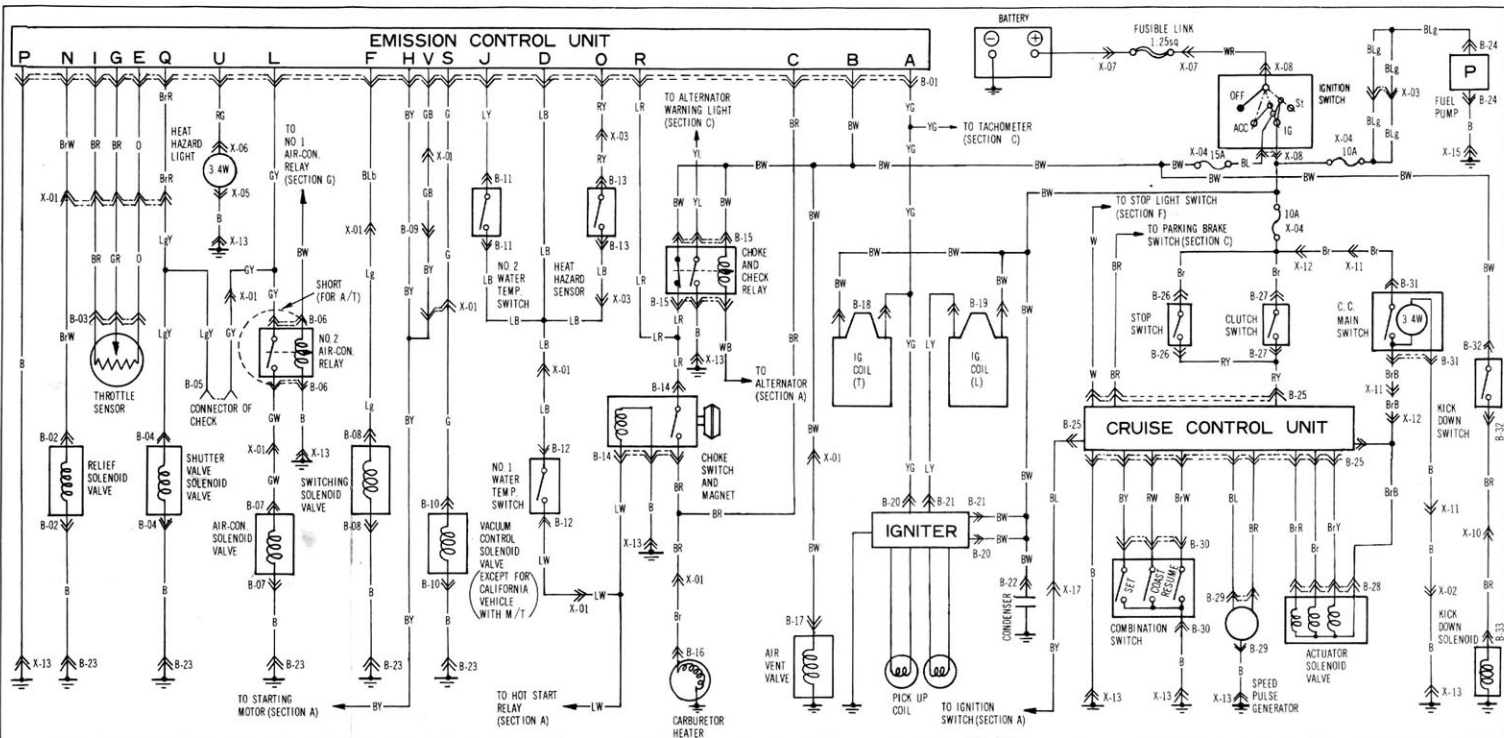



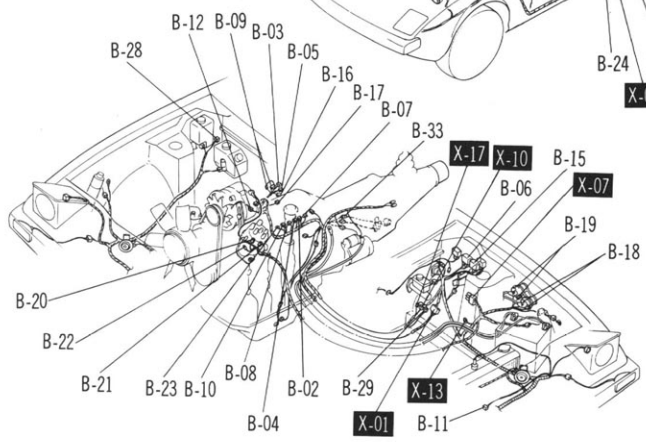
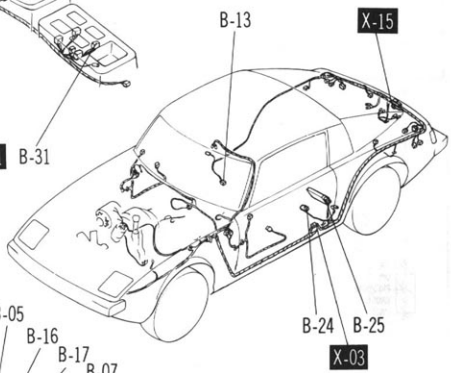
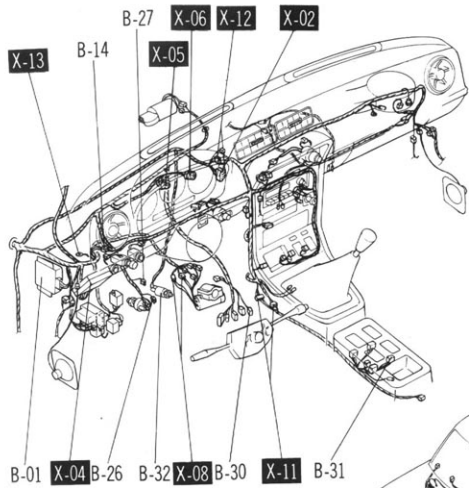

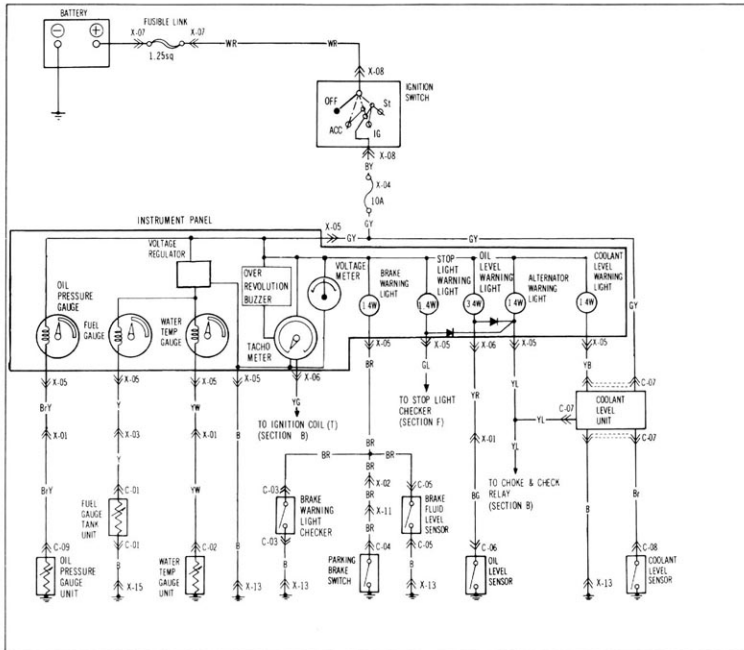
■EMISSION CONTROL SYSTEM ■IGNITION SYSTEM ■CRUISE CONTROL SYSTEM
 ■KICK DOWN SYSTEM(FOR A/T) ■FUEL PUMP



B-01 EMISSION CONTROL UNIT 		B-02 RELIEF SOLENOID VALVE 	B-03 THROTTLE SENSOR 	B-04 SHUTTER VALVE SOLENOID VALVE 	B-05 CONNECTOR OF CHECK 	B-06 NO 2 AIR-CON. RELAY 	B-07 AIR-CON. SOLENOID VALVE 	B-08 SWITCHING SOLENOID VALVE 							
B-09 CARBURETOR HEATER 	B-10 VACUUM CONTROL SOLENOID VALVE 	B-11 NO 2 WATER TEMP. SWITCH (Rad.) 	B-12 NO 1 WATER TEMP. SWITCH (Eng.) 	B-13 HEAT HAZARD SENSOR 	B-14 CHOKE SWITCH AND MAGNET 	B-15 CHOKE AND CHECK RELAY 	B-16 CARBURETOR HEATER 	B-17 AIR VENT VALVE 	B-18 IGNITION COIL (T) 	B-19 IGNITION COIL (L) 	B-20 IGNITER (T) 	B-21 IGNITER (L) 	B-22 CONDENSER 	B-23 GROUND 	B-24 FUEL PUMP
B-25 CRUISE CONTROL UNIT 		B-26 STOP SWITCH 	B-27 CLUTCH SWITCH 	B-28 ACTUATOR SOLENOID VALVE 	B-29 SPEED PULSE GENERATOR 	B-30 COMBINATION SWITCH 	B-31 C.C. MAIN SWITCH 	B-32 KICK DOWN SWITCH 							
B-33 KICK DOWN SOLENOID 															







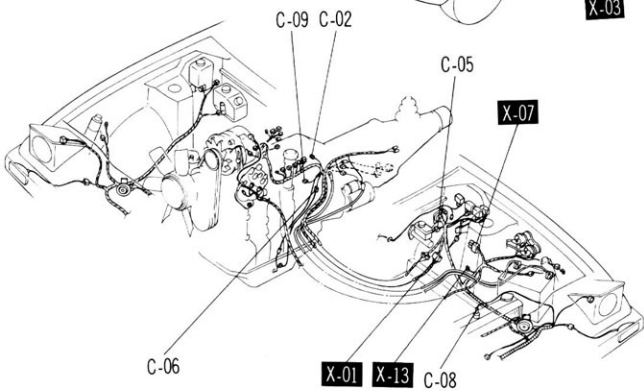
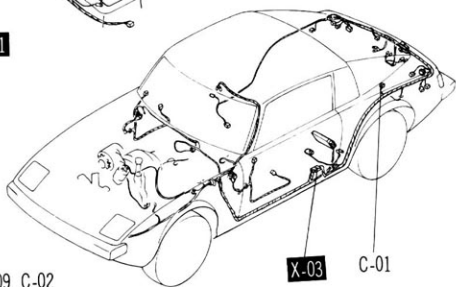
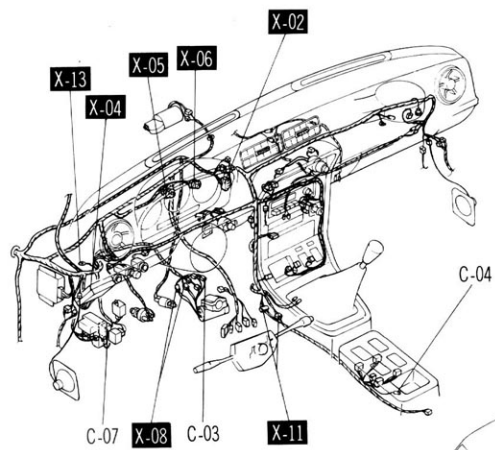

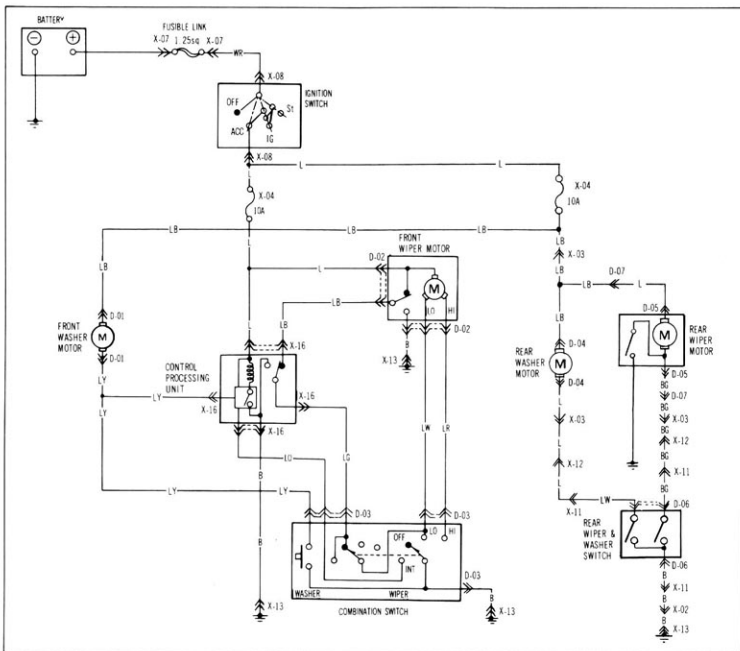

<p>C-01 FUEL GAUGE TANK UNIT</p> 	<p>C-02 WATER TEMP GAUGE UNIT</p> 	<p>C-03 BRAKE WARNING LIGHT CHECKER</p> 	<p>C-04 PARKING BRAKE SWITCH</p> 
<p>C-05 BRAKE FLUID LEVEL SENSOR</p> 	<p>C-06 OIL LEVEL SENSOR</p> 	<p>C-07 COOLANT LEVEL UNIT</p> 	<p>C-08 COOLANT LEVEL SENSOR</p> 
<p>C-09 OIL PRESSURE GAUGE UNIT</p> 			



D**■ FRONT WIPER & WASHER****■ REAR WIPER & WASHER**

<p>D-01 FRONT WASHER MOTOR</p> 	<p>D-02 FRONT WIPER MOTOR</p> 	<p>D-03 COMBINATION SWITCH</p> 	<p>D-04 REAR WASHER MOTOR</p> 
<p>D-05 REAR WIPER MOTOR</p> 	<p>D-06 REAR WIPER & WASHER SWITCH</p> 	<p>D-07 CONNECTOR TO REAR WIPER</p> 	

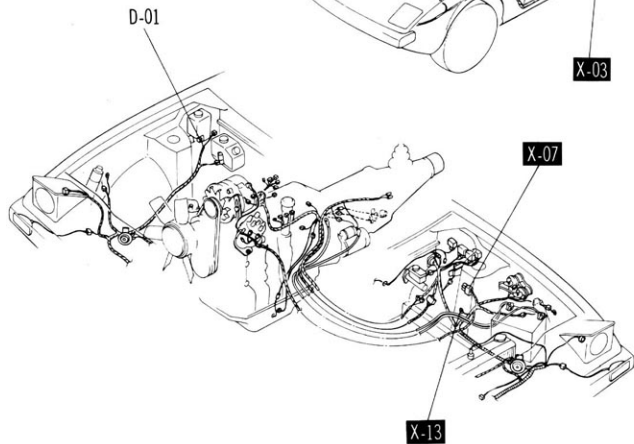
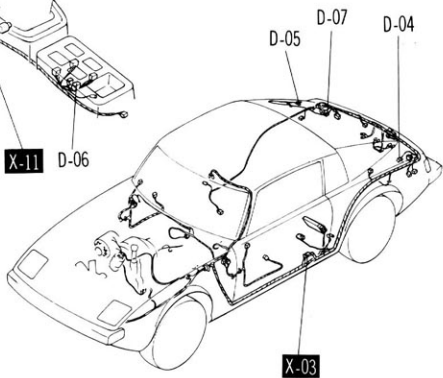
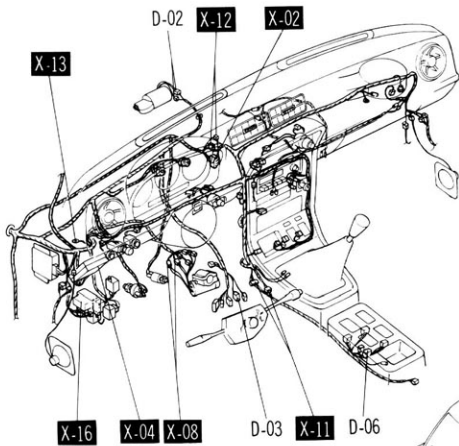

E

■ HEADLIGHTS & ILLUMINATION LIGHTS

■ HEADLIGHT CLEANER

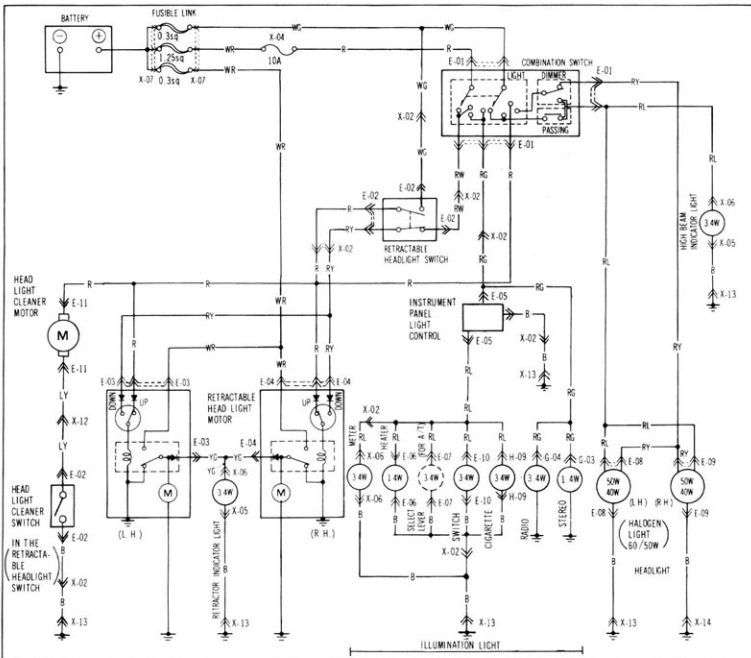

<p>E-01 COMBINATION SWITCH</p>	<p>E-02 RETRACTABLE HEADLIGHT SWITCH</p>	<p>E-03 RETRACTABLE HEADLIGHT MOTOR (L H)</p>	<p>E-04 RETRACTABLE HEADLIGHT MOTOR (R H)</p>
<p>E-05 INSTRUMENT PANEL LIGHT CONTROL</p>	<p>E-06 HEATER ILLUMINATION LIGHT</p>	<p>E-07 SELECT LEVER ILLUMINATION LIGHT (FOR A/T)</p>	<p>E-08 HEADLIGHT (L H)</p>
<p>E-09 HEADLIGHT (R H)</p>	<p>E-10 SWITCH PANEL ILLUMINATION LIGHT</p>	<p>E-11 HEADLIGHT CLEANER MOTOR</p>	
<p>ILLUMINATION LIGHT</p>			

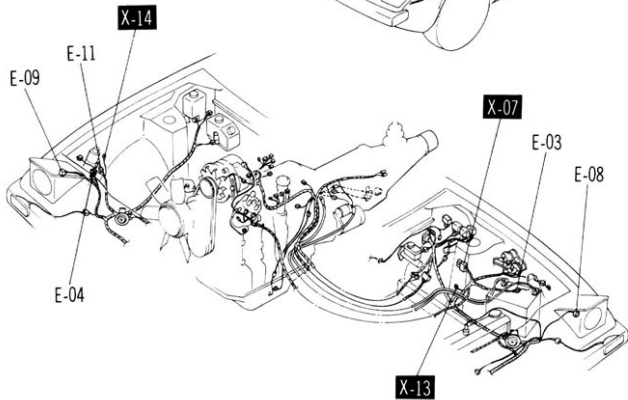
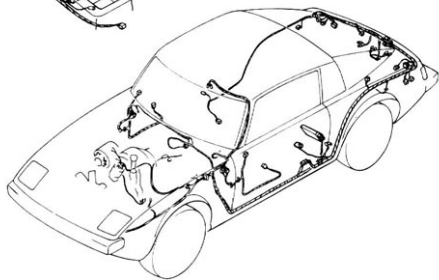
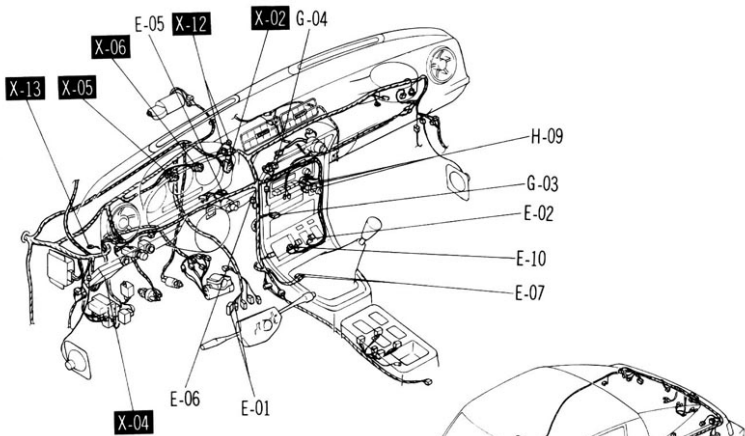

F

■TURN & HAZARD FLASHER LIGHTS ■BACK-UP LIGHTS
 ■STOP LIGHTS ■LICENSE LIGHTS ■HORN
 ■SIDE MARKER LIGHTS ■FRONT PARKING LIGHTS
 ■TAIL LIGHTS

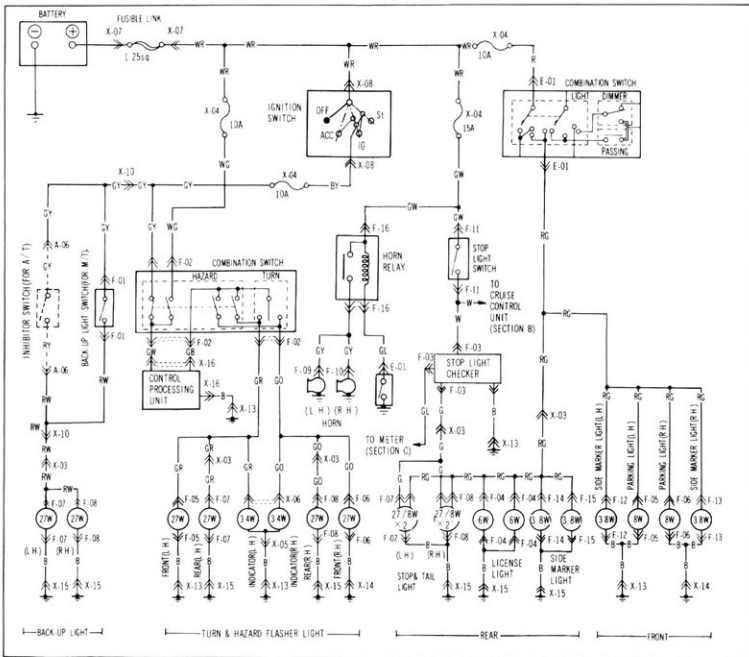

F-01 BACK-UP LIGHT SWITCH 	F-02 COMBINATION SWITCH 	F-03 STOP LIGHT CHECKER 	F-04 LICENSE LIGHT (L H) (R H)
F-05 FRONT TURN & PARKING LIGHT (L H) 	F-06 FRONT TURN & PARKING LIGHT (R H) 	F-07 REAR COMBINATION LIGHT (L H) 	F-08 REAR COMBINATION LIGHT (R H)
F-09 HORN (L H) 	F-10 HORN (R H) 	F-11 STOP LIGHT SWITCH 	F-12 FRONT SIDE MARKER LIGHT (L H)
F-13 FRONT SIDE MARKER LIGHT (R H) 	F-14 REAR SIDE MARKER LIGHT (L H) 	F-15 REAR SIDE MARKER LIGHT (R H) 	F-16 HORN RELAY

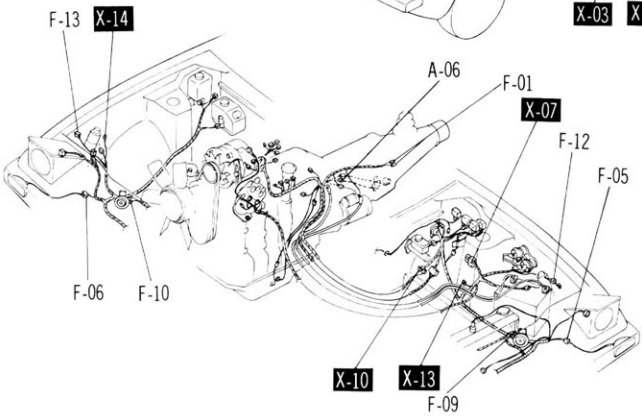
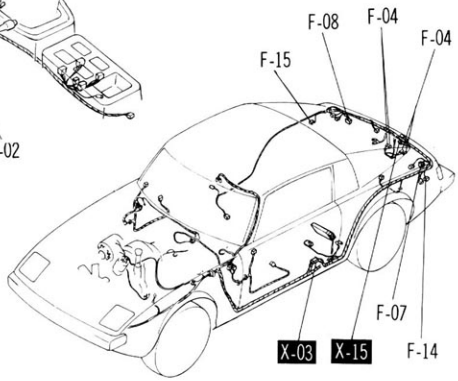
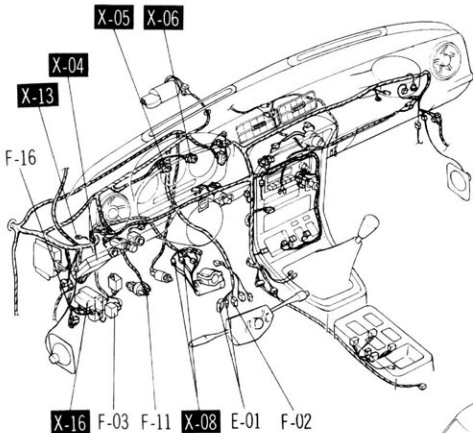

G

■STEREO & RADIO ■POWER ANTENNA
■HEATER & AIR CONDITIONER ■REAR WINDOW DEFROSTER

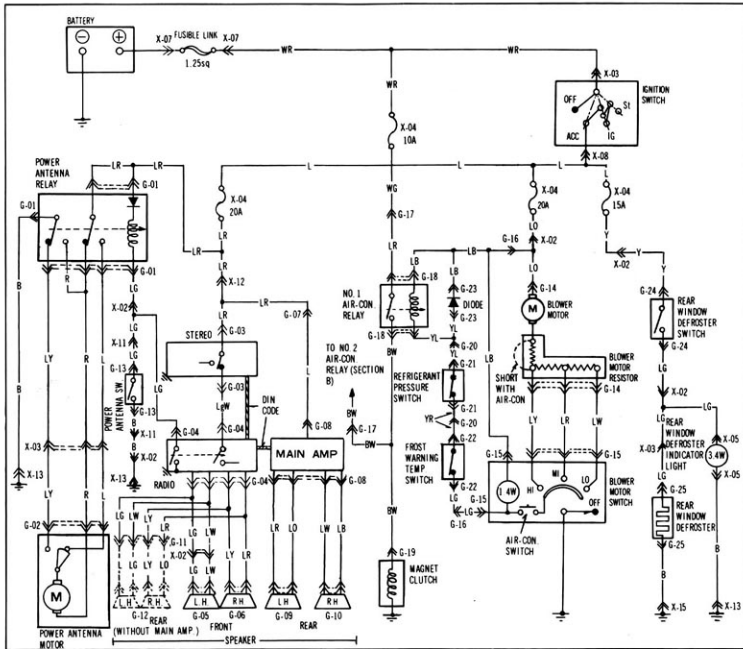

G-01 POWER ANTENNA RELAY 	G-02 POWER ANTENNA MOTOR 	G-03 STEREO 	G-04 RADIO 	G-05 FRONT SPEAKER(L H)
G-06 FRONT SPEAKER(R H) 	G-07 CONNECTOR TO MAIN AMP 	G-08 MAIN AMP 	G-09 REAR SPEAKER(L H) 	G-10 REAR SPEAKER(R H)
G-11 CONNECTOR TO SPEAKER CODE (WITHOUT MAIN AMP.) 	G-12 REAR SPEAKER (WITHOUT MAIN AMP.) 	G-13 POWER ANTENNA SWITCH (WITHOUT RADIO) 	G-14 BLOWER MOTOR 	G-15 BLOWER MOTOR SWITCH
G-16 CONNECTOR BETWEEN INPANE AND AIR-CON HARNESS 	G-17 CONNECTOR BETWEEN FRONT AND AIR-CON HARNESS 	G-18 NO 1 AIR-CON RELAY 	G-19 MAGNET CLUTCH 	G-20 CONNECTOR TO REFRIGERANT PRESSURE SWITCH
G-21 REFRIGERANT PRESSURE SWITCH 	G-22 FROST WARNING TEMP SWITCH 	G-23 DIODE 	G-24 REAR WINDOW DEFROSTER SWITCH 	G-25 REAR WINDOW DEFROSTER

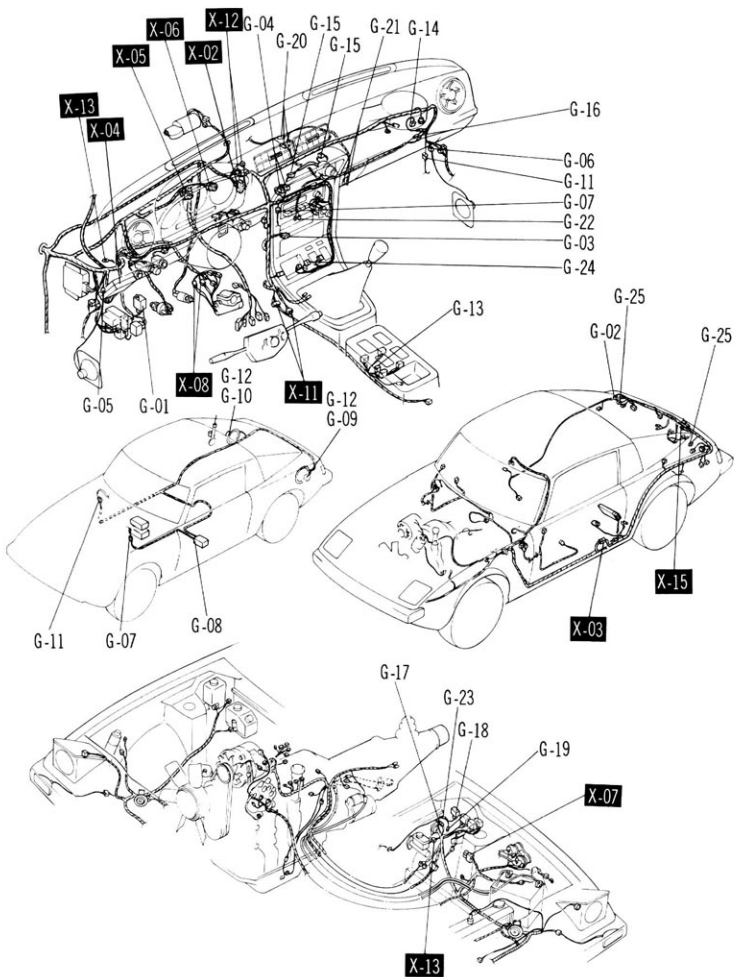

H

- GLOVE BOX LIGHT ■ SEAT BELT WARNING SYSTEM ■ CIGARETTE LIGHTER
- IGNITION KEY REMINDER BUZZER ■ IGNITION SWITCH LIGHT SYSTEM
- INTERIOR AND SPOT LIGHT ■ LIGHTS OFF REMINDER CHIME SYSTEM
- AUTO LOCK ■ LUGGAGE COMPARTMENT LIGHT
- GLASS HATCH RELEASE SYSTEM ■ FUEL-DOOR RELEASE SYSTEM

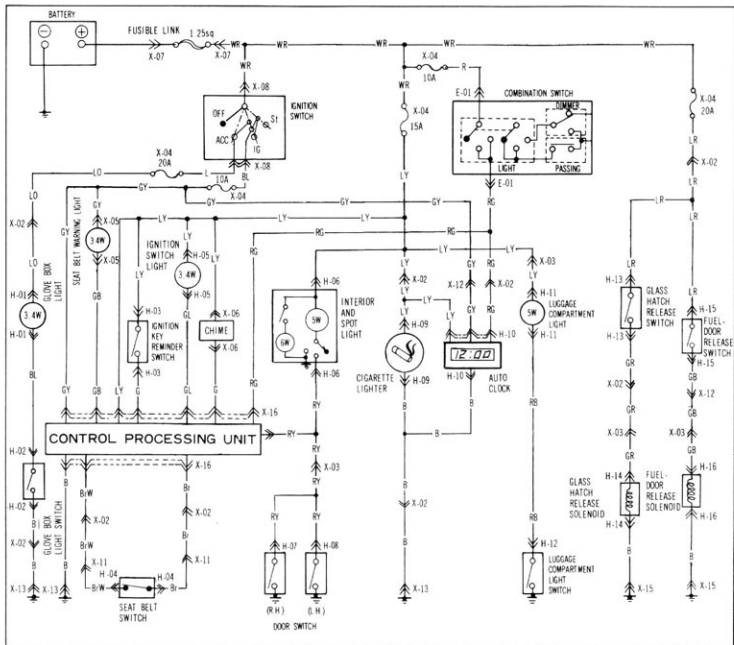

H-01 GLOVE BOX LIGHT 	H-02 GLOVE BOX LIGHT SWITCH 	H-03 IGNITION KEY REMINDER SWITCH 	H-04 SEAT BELT SWITCH
H-05 IGNITION SWITCH LIGHT 	H-06 INTERIOR & SPOT LIGHT 	H-07 DOOR SWITCH(FRONT R H) 	H-08 DOOR SWITCH(REAR L H)
H-09 CIGARETTE LIGHTER 	H-10 AUTO LOCK 	H-11 LUGGAGE COMPARTMENT LIGHT 	H-12 LUGGAGE COMPARTMENT LIGHT SWITCH
H-13 GLASS HATCH RELEASE SWITCH 	H-14 GLASS HATCH RELEASE SOLENOID 	H-15 FUEL-DOOR RELEASE SWITCH 	H-16 FUEL-DOOR RELEASE SOLENOID

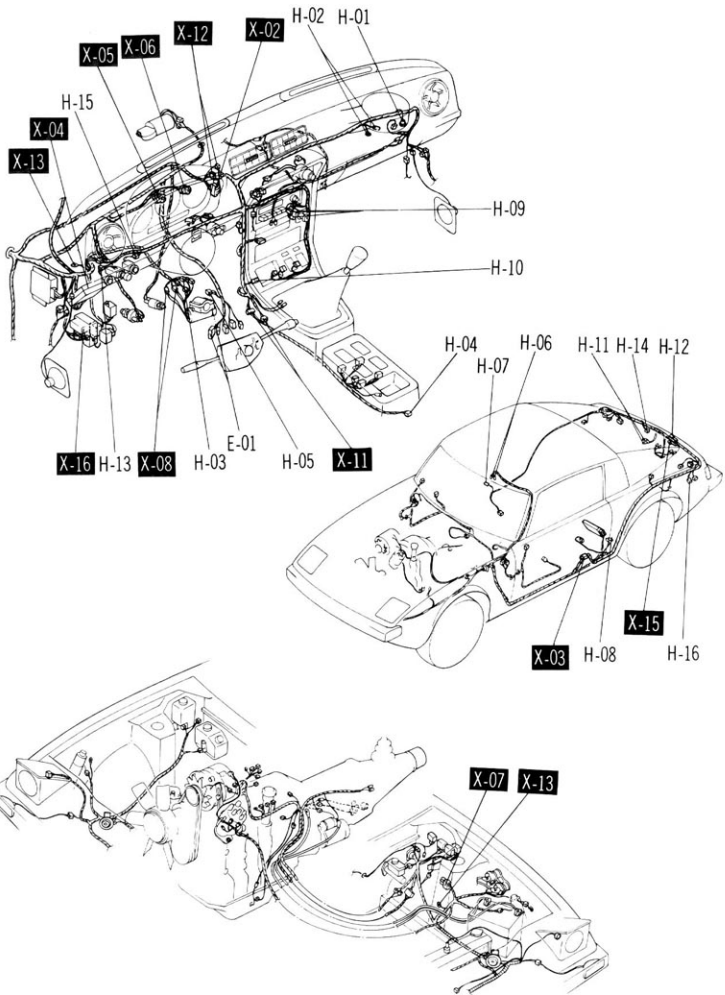

■REMOTE CONTROL MIRROR

■POWER WINDOW

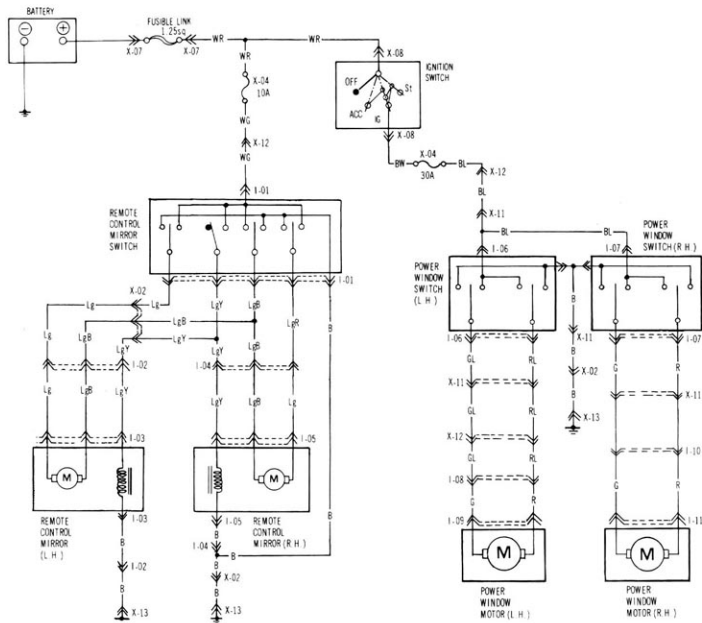

1-01 REMOTE CONTROL MIRROR SWITCH



1-02 CONNECTOR BETWEEN FRONT AND DOOR HARNESS (L.H.)

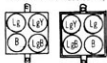

1-03 REMOTE CONTROL MIRROR (L.H.)



1-04 CONNECTOR BETWEEN INPANE AND DOOR HARNESS (R.H.)

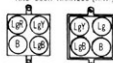

1-05 REMOTE CONTROL MIRROR (R.H.)



1-06 POWER WINDOW SWITCH (L.H.)



1-07 POWER WINDOW SWITCH (R.H.)



1-08 CONNECTOR BETWEEN FRONT AND DOOR HARNESS (L.H.)



1-09 POWER WINDOW MOTOR (L.H.)



1-10 CONNECTOR BETWEEN INPANE AND DOOR HARNESS (R.H.)



1-11 POWER WINDOW MOTOR (R.H.)



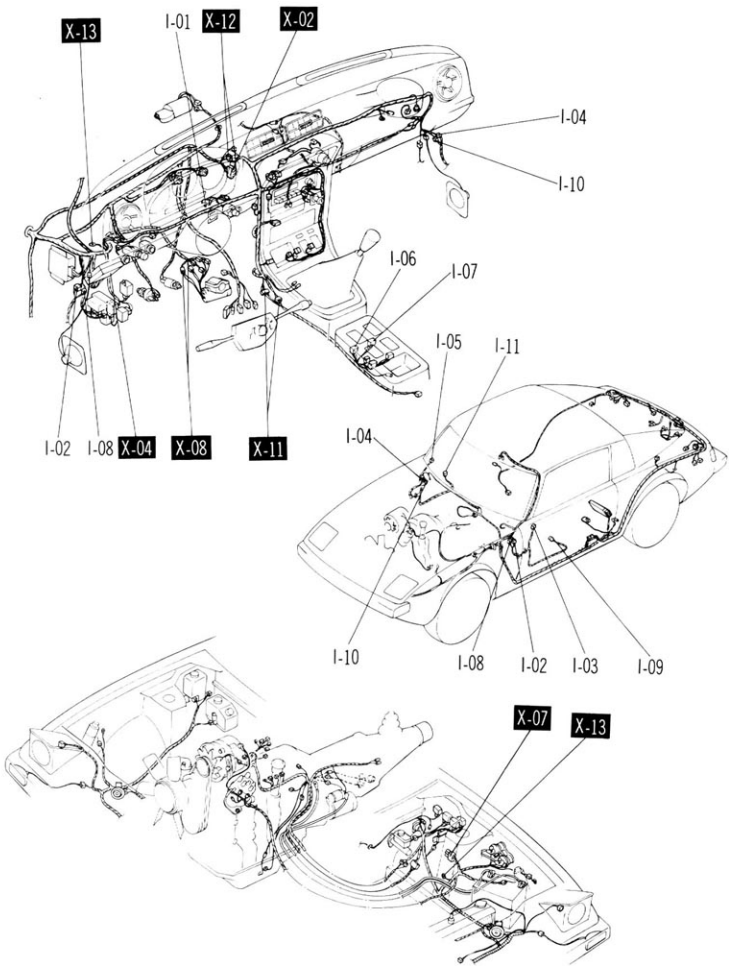

X-01 CONNECTOR BETWEEN FRONT AND ENGINE HARNESSSES

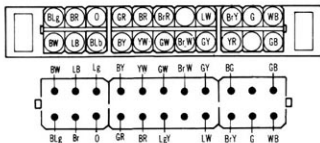

X-02 CONNECTOR BETWEEN FRONT AND INPANE HARNESSSES

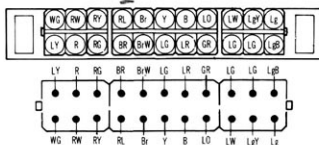

X-03 CONNECTOR BETWEEN FRONT AND REAR HARNESSSES

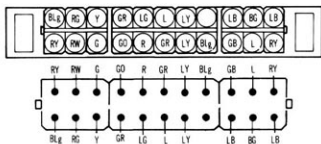

X-04 FUSE BLOCK

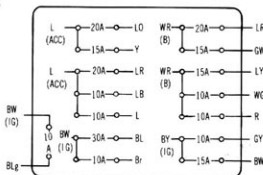

X-05 COMBINATION METER



X-06 COMBINATION METER

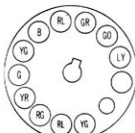

X-07 FUSIBLE LINK WR WR WE

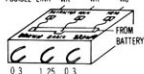

X-08 IGNITION SWITCH



X-09 IGNITION SWITCH



X-10 CONNECTOR TO TRANSMISSION HARNESS

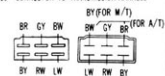

X-11 CONNECTOR BETWEEN INPANE AND PARKING BRAKE HARNESS

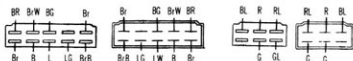

X-12 CONNECTOR BETWEEN FRONT AND INPANE HARNESS

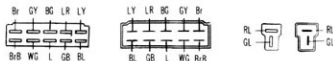

X-13 GROUND



X-14 GROUND



X-15 GROUND



X-16 CONTROL PROCESSING UNIT

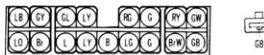

X-17 CONNECTOR TO TRANSMISSION HARNESS



Mazda

RX-7

1981
Wiring Diagram

MAZDA