

This file is available for free download at <http://www.iluvmyrx7.com>



www.iluvmyrx7.com

Parts Catalog

Mazda RX-7
U.S.A.
'89 ▶ '90

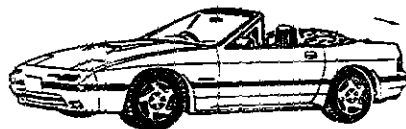
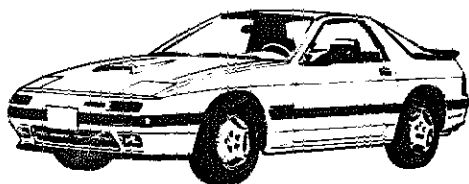

FC3***70001 ~ 90000

May '92 (FINAL)
Catalog No. AU-FA02-05

mazda
© 1992 Mazda Motor Corporation





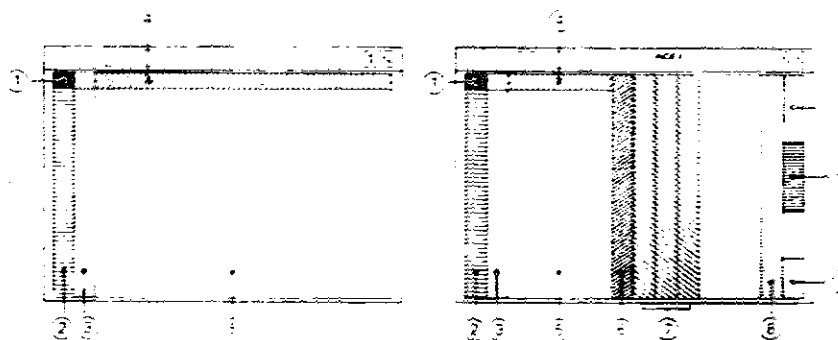





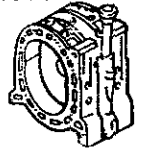

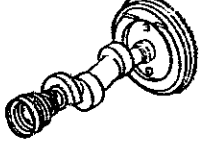
LAYOUT OF CONTENTS

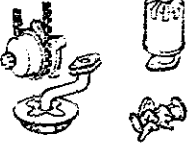
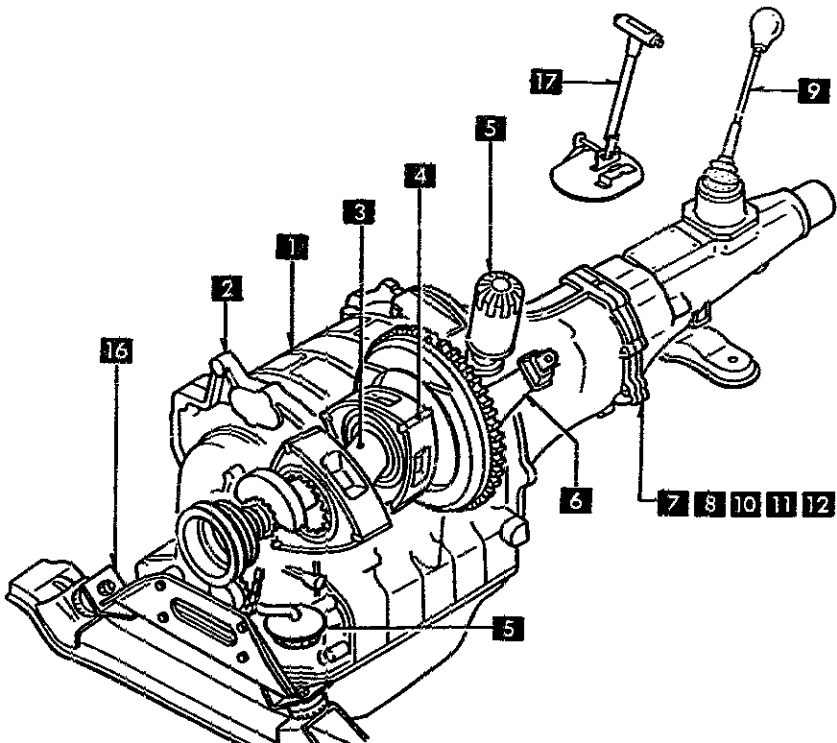
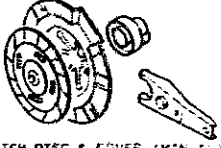
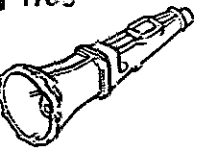
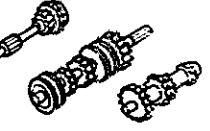
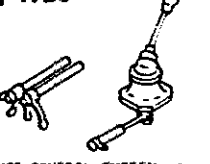
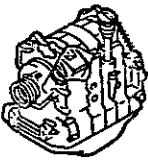
- The following is a typical example of the layout of contents of Mazda microfiche parts cards.

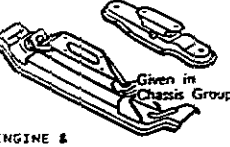
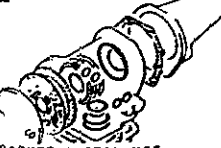

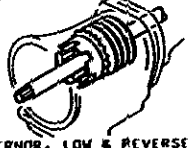

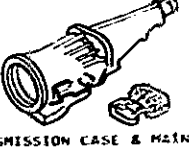







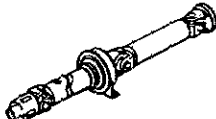
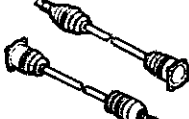
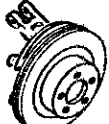

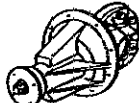
- 1 - Layout of contents
- 2 - Pictorial index
- 3 - Master Section No. Index
- 4 - Section No. Index for the Column
- 5 - Illustration & Text
- 6 - Part No. Index
- 7 - Alphabetical Index
- 8 - Model Identification
- 9 - Vehicle Identification System

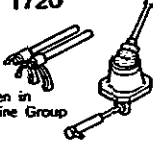
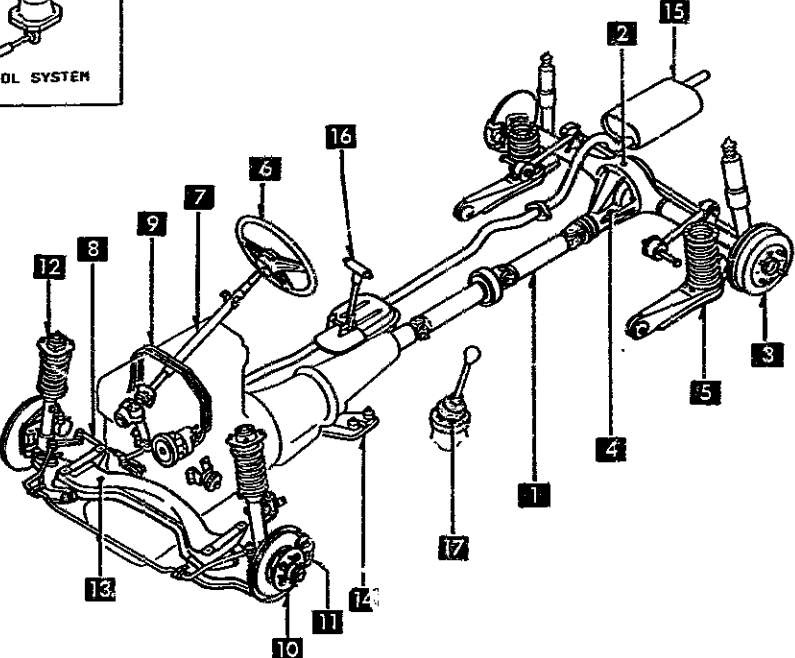
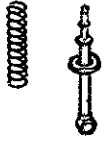
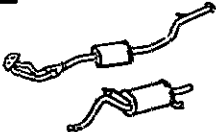
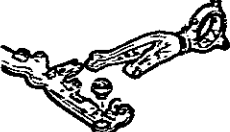
PICTORIAL INDEX

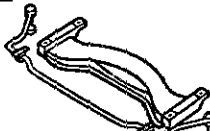
<p>1000</p> 	<p>1 1030</p>  <p>ROTOR HOUSINGS</p>	<p>2 1040</p>  <p>OIL PAN, FRONT & REAR HOUSING</p>	<p>3 1100</p>  <p>ECCENTRIC SHAFT & FLYWHEEL</p>	<p>4 1110</p>  <p>ROTORs & RELATED PARTS</p>	<p>5 1400</p>  <p>OIL PUMP & FILTER</p>			
<p style="text-align: center;">ENGINE (1/2)</p> 						<p>6 1600</p>  <p>CLUTCH DISC & COVER (MANUAL)</p>		
						<p>7 1700</p>  <p>TRANSMISSION CASE (MANUAL)</p>		
						<p>8 1710</p>  <p>TRANSMISSION GEARS (MANUAL)</p>		
						<p>9 1720</p>  <p>CHANGE CONTROL SYSTEM (MANUAL)</p>		
<p>SHORT ENGINE & GASKET SETS</p> 	<p>17 4600</p>  <p>Given in Chassis Group</p> <p>CHANGE CONTROL SYSTEM</p>	<p>16 3900</p>  <p>Given in Chassis Group</p> <p>ENGINE & TRANSMISSION MOUNTINGS</p>	<p>15 1960</p>  <p>GASKET & SEAL KIT (AUTOMATIC)</p>	<p>14 1950</p>  <p>MANUAL LINKAGE SYSTEM (AUTOMATIC)</p>	<p>13 1940</p>  <p>GOVERNOR, LOW & REVERSE PISTON (AUTOMATIC)</p>	<p>12 1930</p>  <p>CLUTCHES & PLANETARY GEARS (AUTOMATIC)</p>	<p>11 1920 1925</p>  <p>TRANSMISSION CASE & MAIN CONTROL SYSTEM (AUTOMATIC)</p>	<p>10 1910</p>  <p>TORQUE CONVERTER, OIL PUMP & PIPINGS (AUTOMATIC)</p>





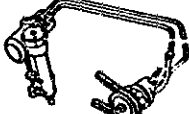
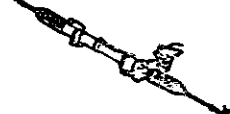





As this illustration is prepared to be applicable to all models, some parts are different in specifications from the parts listed in this parts Catalog

PICTORIAL INDEX

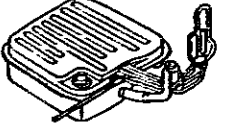
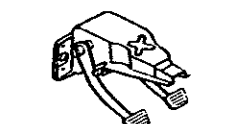
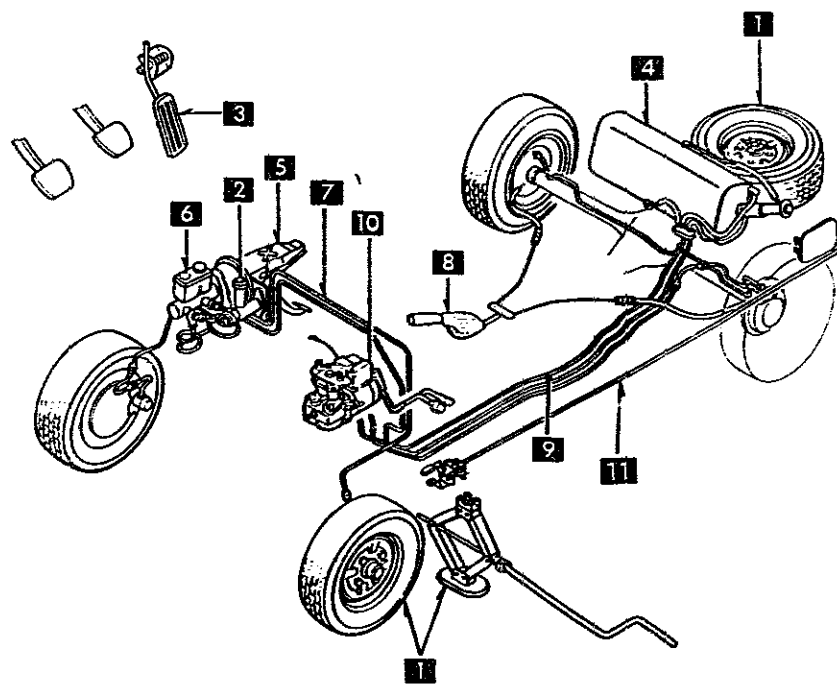
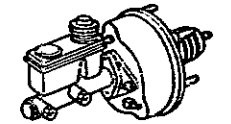







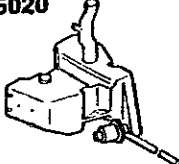

<p>1 2505</p>  <p>REAR PROPELLER SHAFT</p>	<p>2 2550</p>  <p>REAR DRIVE SHAFT</p>	<p>2600</p>  <p>REAR AXLE</p>	<p>3 2610</p>  <p>REAR BRAKE MECHANISMS</p>	<p>4 2710</p>  <p>REAR DIFFERENTIALS</p>	<p>5 2800 2810</p>  <p>REAR SUSPENSION MECHANISMS REAR STABILIZER</p>
<p>16 4600</p>  <p>CHANGE CONTROL SYSTEM (AUTOMATIC)</p>	<p>17 1720</p> <p>Given in Engine Group</p>  <p>CHANGE CONTROL SYSTEM (MANUAL)</p>	<p style="text-align: center;">CHASSIS (1/2)</p> 			<p>2801</p>  <p>REAR SPRING & DAMPER</p>
<p>15 4000</p>  <p>EXHAUST SYSTEM</p>					<p>2830</p>  <p>REAR LOWER ARMS & SUB FRAME</p>
<p>14 3900</p>  <p>ENGINE & TRANSMISSION MOUNTINGS</p>					<p>6 3200</p>  <p>STEERING WHEEL</p>
<p>13 3410</p>  <p>CROSSMEMBER & STABILIZER</p>					<p>7 3210</p>  <p>STEERING COLUMN & SHAFTS</p>
<p>12 3401</p>  <p>FRONT SPRING & DAMPER</p>	<p>3400</p>  <p>FRONT SUSPENSION MECHANISMS</p>	<p>11 3310</p>  <p>FRONT BRAKE MECHANISMS</p>	<p>10 3300</p>  <p>FRONT AXLE</p>	<p>9 3240</p>  <p>POWER STEERING SYSTEM</p>	<p>8 3220</p>  <p>STEERING GEAR</p>

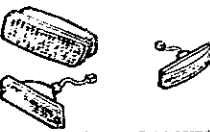
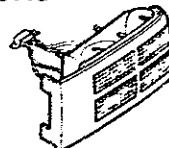
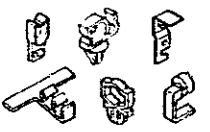
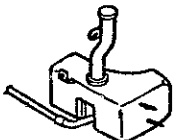
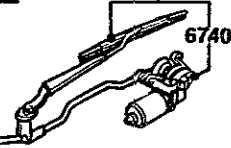
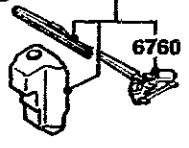
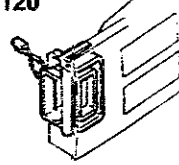
As this illustration is prepared to be applicable to all models, some parts are different in specifications from the parts listed in this parts Catalog.

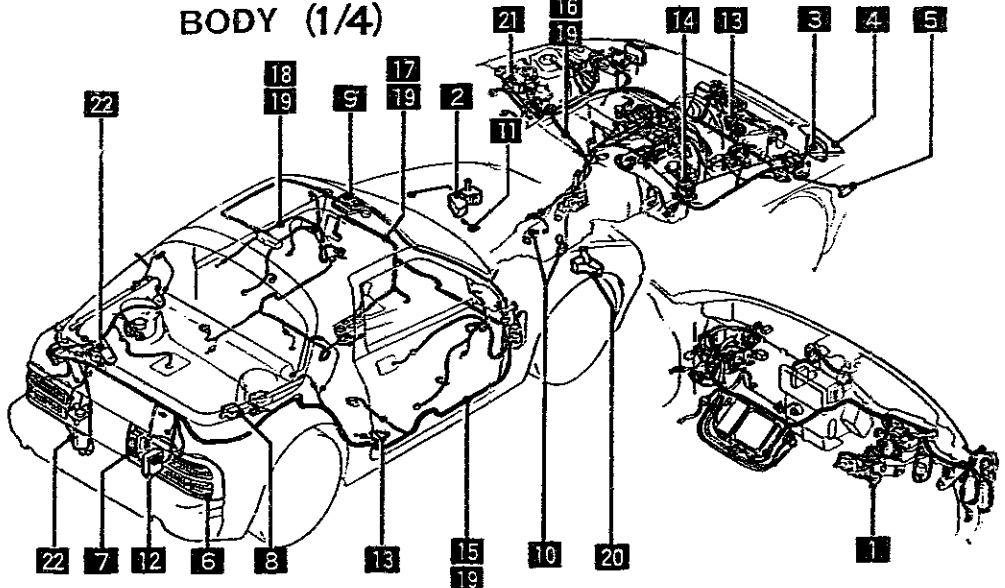
PICTORIAL INDEX

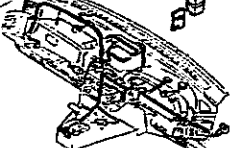

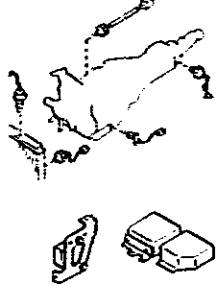

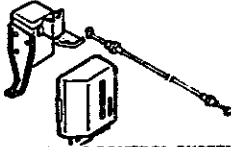







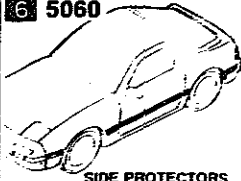

<p>1 3700</p>  <p>TIRES & JACK</p>	<p>2 4140</p>  <p>CLUTCH RELEASE & MASTER CYLINDERS (MANUAL TRANSMISSION)</p>	<p>4145</p>  <p>CLUTCH PIPINGS (MANUAL TRANSMISSION)</p>	<p>3 4160</p>  <p>ACCELERATOR CONTROL SYSTEM</p>	<p>4 4200</p>  <p>FUEL TANK</p>	<p>5 4300</p>  <p>CLUTCH & BRAKE PEDALS (MANUAL TRANSMISSION)</p>			
<p>CHASSIS (2/2)</p> 						<p>6 4340</p>  <p>BRAKE MASTER CYLINDER & POWER BRAKE</p>		
						<p>7 4360</p>  <p>BRAKE PIPINGS</p>		
						<p>8 4400</p>  <p>PARKING BRAKE SYSTEM</p>		
						<p>9 4500</p>  <p>FUEL PIPINGS</p>		
<p><small>As this illustration is prepared to be applicable to all models, some parts are different in specifications from the parts listed in this parts Catalog.</small></p>						<p>11 4210</p>  <p>FUEL LID OPENER</p>		
								<p>10 4370</p>  <p>ANTILOCK BRAKE SYSTEM</p>

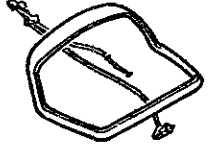
PICTORIAL INDEX

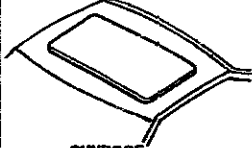
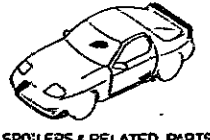
<p>1 0900</p>  <p>KEY SETS</p>	<p>2 5020</p>  <p>HEAD LAMP CLEANER</p>	<p>3 5100</p>  <p>HEAD LAMPS</p>	<p>4 5103</p>  <p>HEAD LAMP RETRACTORS</p>	<p>5 5105</p>  <p>FRONT COMBINATION LAMPS</p>	<p>6 5110</p>  <p>REAR COMBINATION LAMPS</p>
<p>19 6704</p>  <p>WIRING HARNESS CLAMPS</p>	<p>20 6720</p>  <p>WINDSHIELD WASHER</p>	<p>21 6730</p>  <p>WINDSHIELD WIPERS</p>	<p>22 6750</p>  <p>WINDOW WIPER & WASHER (REAR)</p>	<p>7 5120</p>  <p>LICENSE LAMPS</p>	
<p>18 5703</p>  <p>WIRING HARNESSSES (DOOR, FLOOR/CEILING)</p>	<p>BODY (1/4)</p> 				<p>8 5125</p>  <p>INTERIOR LAMPS</p>
<p>17 6702</p>  <p>WIRING HARNESSSES (DASHBOARD)</p>					<p>9 5130</p>  <p>OVERHEAD CONSOLE</p>
<p>16 6701</p>  <p>WIRING HARNESSSES (ENGINE & TRANSMISSION)</p>					<p>10 6600</p>  <p>SWITCHES & RELAYS (ENGINE)</p>
<p>15 6700</p>  <p>WIRING HARNESSSES (FRONT & REAR)</p>					<p>14 6640</p>  <p>AUTO CRUISE CONTROL SYSTEM</p>

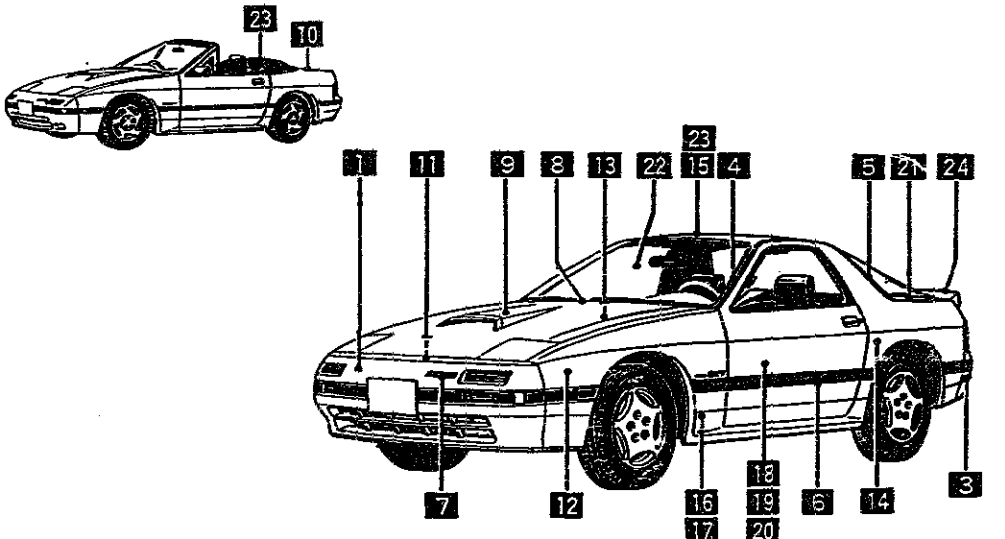
As this illustration is prepared to be applicable to all models, some parts are different in specifications from the parts listed in the parts Catalog.

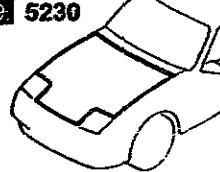
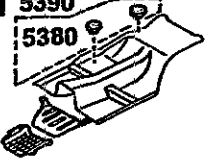
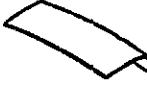
PICTORIAL INDEX

<p>1 5000</p>  <p>FRONT BUMPER</p>	<p>2</p>	<p>3 5010</p>  <p>REAR BUMPER</p>	<p>4 5030</p>  <p>WINDOW MOULDINGS</p>	<p>5 5040</p>  <p>BODY MOULDINGS</p>	<p>6 5060</p>  <p>SIDE PROTECTORS</p>
<p>20 5840</p>  <p>FRONT DOOR TRIMS & RELATED PARTS</p>	<p>21 6230</p>  <p>LIFT GATE MECHANISMS</p>	<p>22 6300</p>  <p>WINDOW GLASSES</p>	<p>23 6330</p>  <p>SUNROOF</p>	<p>24 7800</p>  <p>SPOILERS & RELATED PARTS</p>	<p>7 5170</p> <p>RX-7 MAZDA</p> <p>ORNAMENTS</p>
<p>19 5830</p>  <p>FRONT DOOR MECHANISMS</p>	<p style="text-align: center;">BODY (2/4)</p> 				<p>8 5180</p>  <p>COWL & EXTRACTOR GRILLES</p>
<p>18 5800</p>  <p>FRONT DOORS</p>					<p>9 5230</p>  <p>BONNET</p>
<p>17 5390 5380</p>  <p>FLOOR ATTACHMENTS</p>					<p>10 5260</p>  <p>TRUNK LID</p>
<p>16 5370</p>  <p>BODY PANELS (FLOOR)</p>					<p>15 5360</p>  <p>BODY PANELS (ROOF)</p>





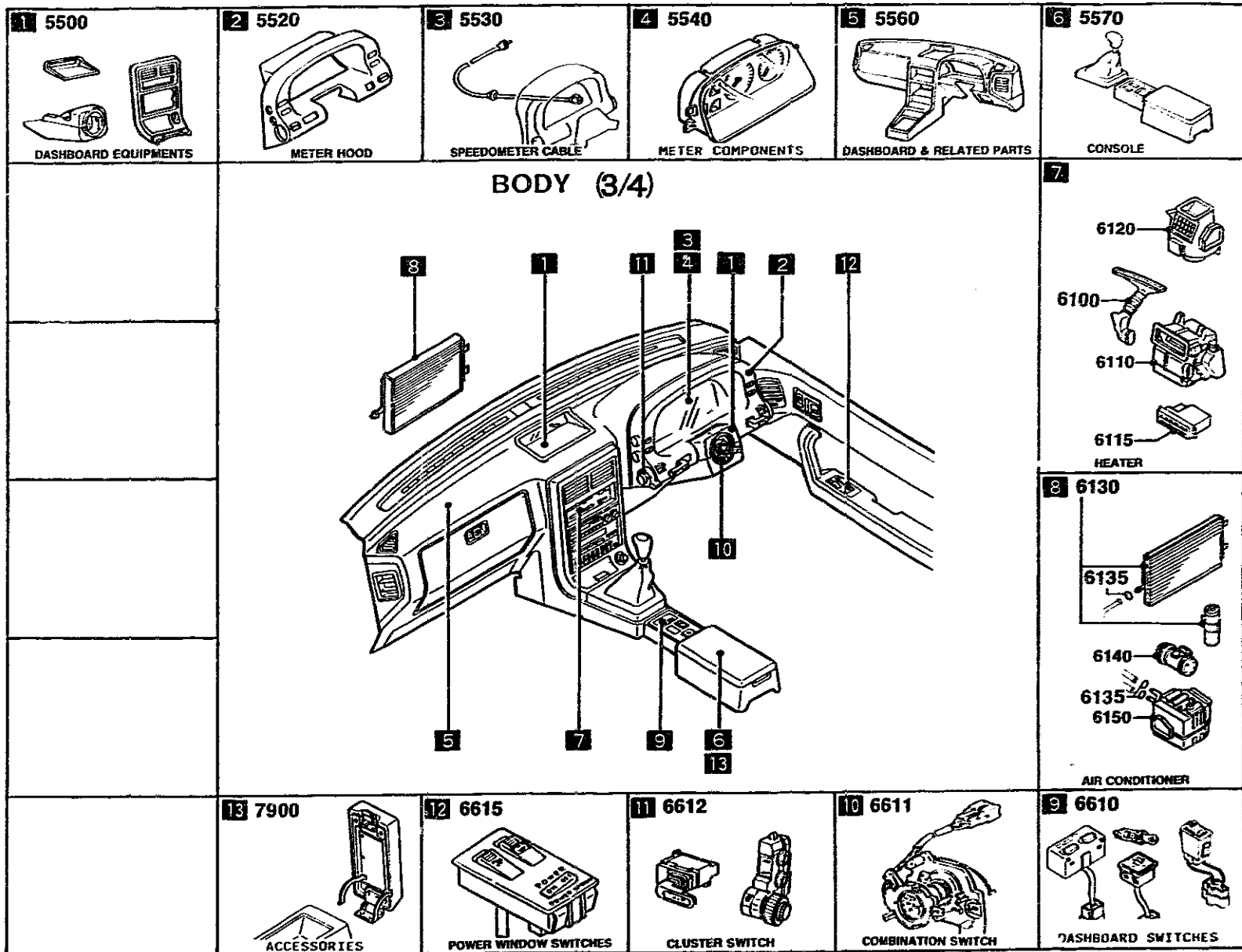



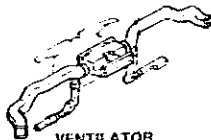

As this illustration is prepared to be applicable to all models, some parts are different in specifications from the parts listed in this parts Catalog.

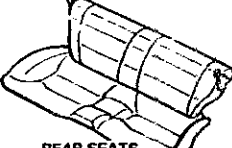
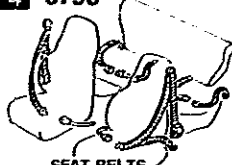
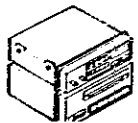
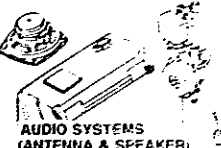
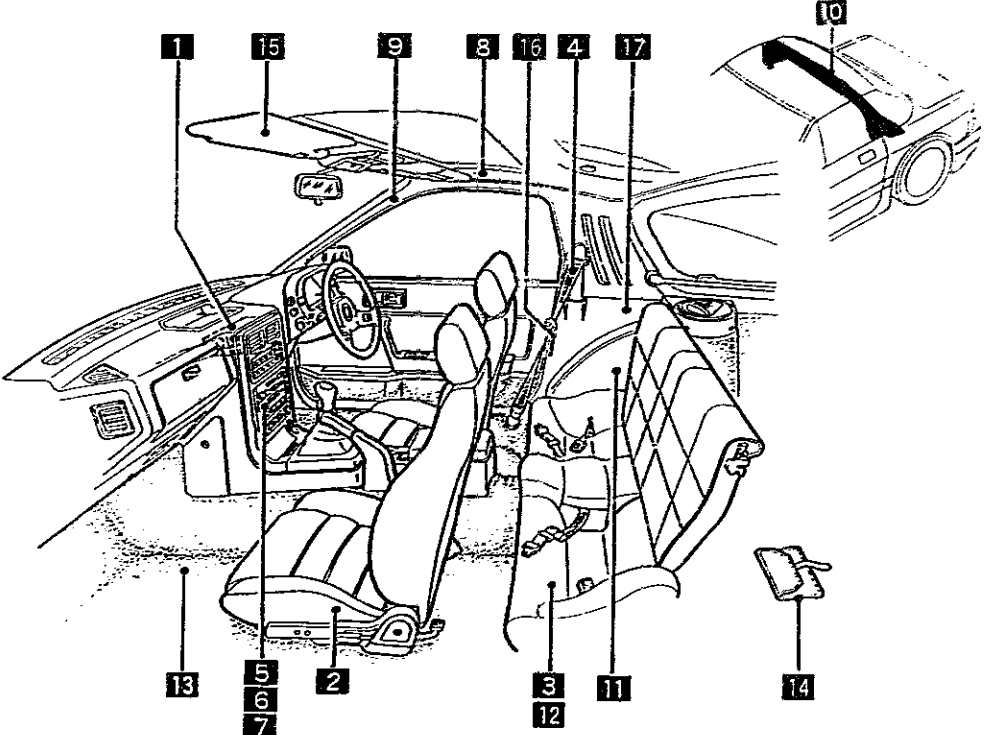
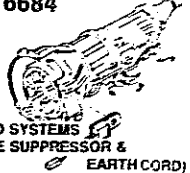
PICTORIAL INDEX

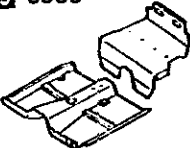
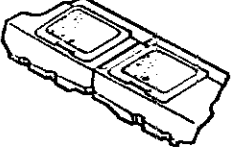

As this illustration is prepared to be applicable to all models, some parts are different in specifications from the parts listed in this parts Catalog.

PICTORIAL INDEX

<p>1 5580</p>  <p>VENTILATOR</p>	<p>2 5700</p>  <p>FRONT SEATS</p>	<p>3 5750</p>  <p>REAR SEATS</p>	<p>4 5790</p>  <p>SEAT BELTS</p>	<p>5 6680</p>  <p>AUDIO SYSTEMS (RADIO & TAPE DECK)</p>	<p>6 6682</p>  <p>AUDIO SYSTEMS (ANTENNA & SPEAKER)</p>	
<p>BODY (4/4)</p> 						<p>7 6684</p>  <p>AUDIO SYSTEMS (NOISE SUPPRESSOR & EARTH CORD)</p>
						<p>8 6800</p>  <p>CEILING TRIMS</p>
						<p>9 6820</p>  <p>PILLAR TRIMS</p>
<p>17 7250</p>  <p>QUARTER WINDOW & TRIMS</p>	<p>13 6930</p>  <p>CAUTION PLATES & LABELS</p>					
						<p>15 6900</p>  <p>VISORS, ASSIST HANDLES & MIRRORS</p>
						<p>14 6870</p>  <p>SERVICE TOOLS</p>
						<p>13 6860</p>  <p>FLOOR MATS & PADS</p>
						<p>12 6845</p>  <p>STORAGE BOX</p>
						<p>11 6840</p>  <p>TRIMS & SCUFF PLATES</p>

As this illustration is prepared to be applicable to all models, some parts are different in specifications from the parts listed in this parts Catalog

SECTION NAME INDEX (ENGINE)

LO.NO	SEC.NO	SECTION NAME	LO.NO	SEC.NO	SECTION NAME	LO.NO	SEC.NO	SECTION NAME
1-C03	1000	SHORT ENGINE & GASKET SETS (W/O TURBO)	1-G11	1840	STARTER			
1-D03	1000 A	SHORT ENGINE & GASKET SETS (TURBO)	1-J11	1850	BATTERY			
1-E03	1030	ROTOR HOUSINGS (W/O TURBO)	1-K11	1910	TORQUE CONVERTER, OIL PUMP & PI PINGS (AUTOMATIC)			
1-G03	1030 A	ROTOR HOUSINGS (TURBO)	1-N11	1920	TRANSMISSION CASE & MAIN CONTR OL SYSTEM (AUTOMATIC)			
1-J03	1040	OIL PAN, FRONT & REAR HOUSING (W/O TURBO)	1-I12	1925	CONTROL VALVE (AUTOMATIC)			
1-M03	1040 A	OIL PAN, FRONT & REAR HOUSING (TURBO)	1-D13	1930	CLUTCHES & PLANETARY GEARS (AUTOMATIC)			
1-D04	1100	ECCENTRIC SHAFT & FLYWHEEL	1-L13	1940	GOVERNOR, LOW & REVERSE PISTON (AUTOMATIC)			
1-G04	1110	ROTORS & RELATED PARTS	1-C14	1950	MANUAL LINKAGE SYSTEM (AUTOMATIC)			
1-I04	1300	INLET MANIFOLD	1-E14	1960	GASKET & SEAL KIT (AUTOMATIC)			
1-M04	1310	EXHAUST MANIFOLD						
1-N04	1311	INTER COOLER (TURBO)						
1-C05	1312	TURBO CHARGER (TURBO)						
1-F05	1320	FUEL SYSTEM						
1-H05	1325	FUEL DISTRIBUTOR						
1-I05	1330	AIR CLEANER						
1-M05	1350	STARTING ASSIST SYSTEM						
1-N05	1364	THROTTLE BODY						
1-F06	1371	AIR PUMP & AIR CONTROL VALVE						
1-I06	1380	EMISSION CONTROL SYSTEM						
1-D07	1399	CAP & HOSE CLIP (INLET & EXHAUST SIDE)						
1-F07	1400	OIL PUMP & FILTER (W/O TURBO)						
1-I07	1400 A	OIL PUMP & FILTER (TURBO)						
1-M07	1500	COOLING SYSTEM						
1-F08	1580	BRACKET, PULLEY & BELT						
1-C09	1600	CLUTCH DISC & COVER (MANUAL)						
1-F09	1700	TRANSMISSION CASE (MANUAL)						
1-J09	1710	TRANSMISSION GEARS (MANUAL)						
1-H10	1720	CHANGE CONTROL SYSTEM (MANUAL)						
1-M10	1800	ENGINE ELECTRICAL SYSTEM						
1-E11	1830	ALTERNATOR						

CATLOG-NO- AUFA02-06

DATE. 1992-05

SECTION NAME INDEX (CHASSIS)

LO.NO	SEC.NO	SECTION NAME	LO.NO	SEC.NO	SECTION NAME	LO.NO	SEC.NO	SECTION NAME
2-C03	2505	REAR PROPELLER SHAFT	2-M08	4140	CLUTCH RELEASE & MASTER CYLINDERS (MANUAL TRANSMISSION)			
2-D03	2550	REAR DRIVE SHAFT	2-C09	4145	CLUTCH PIPINGS (MANUAL TRANSMISSION)			
2-E03	2600	REAR AXLE	2-D09	4160	ACCELERATOR CONTROL SYSTEM			
2-G03	2610	REAR BRAKE MECHANISMS	2-E09	4200	FUEL TANK			
2-K03	2710	REAR DIFFERENTIALS (NORMAL DIFF.)	2-H09	4300	CLUTCH & BRAKE PEDALS (MANUAL TRANSMISSION)			
2-C04	2710 A	REAR DIFFERENTIALS (LIMITED SLIP DIFF.)	2-K09	4300A	BRAKE PEDALS (AUTOMATIC TRANSMISSION)			
2-H04	2800	REAR SUSPENSION MECHANISMS	2-M09	4340	BRAKE MASTER CYLINDER & POWER BRAKE (W/O TURBO)			
2-J04	2801	REAR SPRING & DAMPER	2-C10	4340 A	BRAKE MASTER CYLINDER & POWER BRAKE (TURBO)			
2-K04	2810	REAR STABILIZER	2-E10	4360	BRAKE PIPINGS (W/O TURBO)			
2-L04	2830	REAR LOWER ARMS & SUB FRAME	2-G10	4360 A	BRAKE PIPINGS (TURBO)			
2-N04	3200	STEERING WHEEL (W/O AIR BAG)	2-J10	4370	ANTILOCK BRAKE SYSTEM (TURBO)			
2-E05	3200 A	STEERING WHEEL (W/ AIR BAG)	2-N10	4400	PARKING BRAKE SYSTEM			
2-G05	3210	STEERING COLUMN & SHAFTS	2-D11	4500	FUEL PIPINGS			
2-I05	3220 A	STEERING GEAR (W/ POWER STEERING:ENGINE REVOLUTION PER MINUTE SENSOR) (GTU, '90-GX L, '90-CONV-W/O AIR BAG)	2-H11	4600	CHANGE CONTROL SYSTEM (AT)			
2-L05	3220 B	STEERING GEAR (W/ POWER STEERING:VELOCITY SENSOR) (GTUS, '90-G XL.TURBO, '89-CONV, '90-CONV-W/AIR BAG)						
2-C06	3240	POWER STEERING SYSTEM						
2-F06	3300	FRONT AXLE						
2-H06	3310	FRONT BRAKE MECHANISMS						
2-K06	3400	FRONT SUSPENSION MECHANISMS						
2-M06	3401	FRONT SPRING & DAMPER						
2-N06	3410	CROSSMEMBER & STABILIZER						
2-C07	3700	TIRES & JACK						
2-C08	3900	ENGINE & T/MISSION MOUNTINGS (MT)						
2-D08	3900A	ENGINE & T/MISSION MOUNTINGS (AT)						
2-E08	4000	EXHAUST SYSTEM (W/O TURBO)						
2-I08	4000 A	EXHAUST SYSTEM (TURBO)						

CATLOG-NO= AUF02-06

DATE. 1992-05

SECTION NAME INDEX (BODY) 1/2

LO.NO	SEC.NO	SECTION NAME	LO.NO	SEC.NO	SECTION NAME	LO.NO	SEC.NO	SECTION NAME
3-C03	0900	KEY SETS	3-J09	5390	FLOOR ATTACHMENTS			
3-F03	5000	FRONT BUMPER	3-C10	5500	DASHBOARD EQUIPMENTS			
3-H03	5010	REAR BUMPER	3-F10	5520	METER HOOD			
3-J03	5020	HEAD LAMP CLEANER	3-G10	5530	SPEEDOMETER CABLE			
3-L03	5030	WINDOW MOULDINGS	3-H10	5540	METER COMPONENTS			
3-M03	5040	BODY MOULDINGS (COUPE)	3-J10	5560	DASHBOARD & RELATED PARTS			
3-E04	5060	SIDE PROTECTORS	3-E11	5570	CONSOLE			
3-I04	5100	HEAD LAMPS	3-H11	5580	VENTILATOR			
3-J04	5103	HEAD LAMP RETRACTORS	3-J11	5700	FRONT SEATS (COUPE)			
3-N04	5105	FRONT COMBINATION LAMPS	3-E13	5700A	FRONT SEATS (CONVERTIBLE)			
3-G05	5110	REAR COMBINATION LAMPS	3-K13	5750	REAR SEATS (COUPE)			
3-K05	5120	LICENSE LAMPS	3-M13	5790	SEAT BELTS (COUPE)			
3-M05	5125	INTERIOR LAMPS	3-C14	5790A	SEAT BELTS (CONVERTIBLE)			
3-N05	5130	OVERHEAD CONSOLE	3-D14	5800	FRONT DOORS (COUPE)			
3-C06	5170	ORNAMENTS	3-G14	5800A	FRONT DOORS (CONVERTIBLE)			
3-D06	5180	COWL & EXTRACTOR GRILLES	3-K14	5830	FRONT DOOR MECHANISMS (COUPE)			
3-G06	5230	BONNET	3-F15	5830A	FRONT DOOR MECHANISMS (CONVERTIBLE)			
3-J06	5260	TRUNK LID (CONVERTIBLE)	3-J15	5840	FRONT DOOR TRIMS & RELATED PARTS (COUPE)			
3-L06	5310	BODY PANELS (FRONT) (COUPE)	3-H16	5840A	FRONT DOOR TRIMS & RELATED PARTS (CONVERTIBLE)			
3-C07	5310 A	BODY PANELS (FRONT) (CONVERTIBLE)						
3-F07	5320	BODY PANELS (FENDER & WHEEL ARCH)						
3-K07	5330	BODY PANELS (DASH & COWL PANEL)						
3-L07	5340	BODY PANELS (SIDE) (COUPE)						
3-E08	5340A	BODY PANELS (SIDE) (CONVERTIBLE)						
3-K08	5360	BODY PANELS (ROOF) (W/O SUN ROOF)						
3-L08	5360 A	BODY PANELS (ROOF) (SUN ROOF)						
3-M08	5370	BODY PANELS (FLOOR) (COUPE)						
3-D09	5370 A	BODY PANELS (FLOOR) (CONVERTIBLE)						
3-H09	5380	FLOOR ATTACHMENTS (HOLE COVERS)						

SECTION NAME INDEX (BODY) 2/2

LO.NO	SEC.NO	SECTION NAME	LO.NO	SEC.NO	SECTION NAME	LO.NO	SEC.NO	SECTION NAME
4-C03	6100	HEATER	4-E08	6703	WIRING HARNESSSES(DOOR,FLOOR/CEILING)			
4-E03	6110	HEATER UNIT COMPONENTS	4-G08	6704	WIRING HARNESS CLAMPS			
4-F03	6115	HEATER CONTROLS COMPONENTS	4-J08	6720	WINDSHIELD WASHER (1.5L & 2.5L)			
4-G03	6120	HEATER BLOWER COMPONENTS	4-L08	6720 A	WINDSHIELD WASHER (5.7L)			
4-I03	6130	AIR CONDITIONER	4-N08	6730	WINDSHIELD WIPERS			
4-J03	6230	LIFT GATE MECHANISMS (COUPE)	4-C09	6740	WIPER MOTOR COMPONENTS(FRONT)			
4-M03	6300	WINDOW GLASSES (COUPE)	4-D09	6750	WINDOW WIPER & WASHER (REAR)			
4-N03	6300A	WINDOW GLASSES (CONVERTIBLE)	4-G09	6760	WINDOW WIPER MOTOR COMPONENTS (REAR)			
4-C04	6330	SUNROOF (COUPE)	4-H09	6800	CEILING TRIMS (COUPE)			
4-G04	6330A	SUNROOF (CONVERTIBLE)	4-J09	6800A	CEILING TRIMS (CONVERTIBLE)			
4-M04	6600	SWITCHES & RELAYS (ENGINE)	4-K09	6810	ROLLEBAR (CONVERTIBLE)			
4-G05	6610	DASHBOARD SWITCHES	4-N09	6820	PILLAR TRIMS (COUPE)			
4-H05	6611	COMBINATION SWITCH	4-F10	6820A	PILLAR TRIMS (CONVERTIBLE)			
4-I05	6612	CLUSTER SWITCH	4-G10	6840	TRIMS & SCUFF PLATES (COUPE)			
4-L05	6615	POWER WINDOW SWITCHES	4-L10	6840A	TRIMS & SCUFF PLATES (CONVERTIBLE)			
4-M05	6630	RELAYS & UNIT (BODY)	4-N10	6845	STRAGE BOX (COUPE)			
4-D06	6635	DOOR SWITCH & HORNS						(GXL,TURBO)
4-E06	6640	AUTO CRUISE CONTROL SYSTEM	4-D11	6860	FLOOR MATS & PADS (COUPE)			
4-F06	6680	AUDIO SYSTEMS (RADIO & TAPE DECK) (COUPE)	4-K11	6860A	FLOOR MATS & PADS (CONVERTIBLE)			
4-K06	6680 A	AUDIO SYSTEMS (RADIO & TAPE DECK) (CONVERTIBLE)	4-C12	6870	SERVICE TOOLS			
4-M06	6682	AUDIO SYSTEMS (ANTENNA & SPEAKER) (COUPE)	4-D12	6900	VISORS,ASSIST HANDLES & MIRRORS (COUPE)			
4-D07	6682 A	AUDIO SYSTEMS (ANTENNA & SPEAKER) (CONVERTIBLE)	4-H12	6900A	VISORS,ASSIST HANDLES & MIRRORS (CONVERTIBLE)			
4-G07	6684	AUDIO SYSTEMS(NOISE SUPPRESSOR & EARTH CORD)	4-K12	6930	CAUTION PLATES & LABELS			
4-H07	6700	WIRING HARNESSSES(FRONT & REAR)	4-N12	7250	QUARTER WINDOW & TRIMS			
4-N07	6701	WIRING HARNESSSES(ENGINE & TRANSMISSION)	4-E13	7800	SPOILERS & RELATED PARTS			
4-D08	6702	WIRING HARNESSSES(DASHBOARD)	4-C14	7900	ACCESSORIES			

SECTION NAME INDEX (BODY) 2/2

LD.NO	SEC.NO	SECTION NAME	LD.NO	SEC.NO	SECTION NAME	LD.NO	SEC.NO	SECTION NAME
4-C03	6100	HEATER	4-E08	6703	WIRING HARNESSES(DOOR,FLOOR/CEILING)			
4-E03	6110	HEATER UNIT COMPONENTS	4-G08	6704	WIRING HARNESS CLAMPS			
4-F03	6115	HEATER CONTROLS COMPONENTS	4-J08	6720	WINDSHIELD WASHER (1.5L & 2.5L)			
4-G03	6120	HEATER BLOWER COMPONENTS	4-L08	6720 A	WINDSHIELD WASHER (5.7L)			
4-I03	6130	AIR CONDITIONER	4-N08	6730	WINDSHIELD WIPERS			
4-J03	6230	LIFT GATE MECHANISMS (COUPE)	4-C09	6740	WIPER MOTOR COMPONENTS(FRONT)			
4-M03	6300	WINDOW GLASSES (COUPE)	4-D09	6750	WINDOW WIPER & WASHER (REAR)			
4-N03	6300A	WINDOW GLASSES (CONVERTIBLE)		6760	WINDOW WIPER MOTOR COMPONENTS (REAR)			
4-C04	6330	SUNROOF (COUPE)	4-H09	6800	CEILING TRIMS (COUPE)			
4-G04	6330A	SUNROOF (CONVERTIBLE)	4-J09	6800A	CEILING TRIMS (CONVERTIBLE)			
4-M04	6600	SWITCHES & RELAYS (ENGINE)	4-K09	6810	ROLLEBAR (CONVERTIBLE)			
4-G05	6610	DASHBOARD SWITCHES	4-N09	6820	PILLAR TRIMS (COUPE)			
4-H05	6611	COMBINATION SWITCH	4-F10	6820A	PILLAR TRIMS (CONVERTIBLE)			
4-I05	6612	CLUSTER SWITCH	4-G10	6840	TRIMS & SCUFF PLATES (COUPE)			
4-L05	6615	POWER WINDOW SWITCHES	4-L10	6840A	TRIMS & SCUFF PLATES (CONVERTIBLE)			
4-M05	6630	RELAYS & UNIT (BODY)	4-N10	6845	STRAGE BOX (COUPE)			
4-D06	6635	DOOR SWITCH & HORNS						(GXL,TURBO)
4-E06	6640	AUTO CRUISE CONTROL SYSTEM	4-D11	6860	FLOOR MATS & PADS (COUPE)			
4-F06	6680	AUDIO SYSTEMS (RADIO & TAPE DECK) (COUPE)	4-K11	6860A	FLOOR MATS & PADS (CONVERTIBLE)			
4-K06	6680 A	AUDIO SYSTEMS (RADIO & TAPE DECK) (CONVERTIBLE)	4-C12	6870	SERVICE TOOLS			
4-M06	6682	AUDIO SYSTEMS (ANTENNA & SPEAKER) (COUPE)	4-D12	6900	VISORS,ASSIST HANDLES & MIRRORS (COUPE)			
4-D07	6682 A	AUDIO SYSTEMS (ANTENNA & SPEAKER) (CONVERTIBLE)	4-H12	6900A	VISORS,ASSIST HANDLES & MIRRORS (CONVERTIBLE)			
4-G07	6684	AUDIO SYSTEMS(NOISE SUPPRESSOR & EARTH CORD)	4-K12	6930	CAUTION PLATES & LABELS			
4-H07	6700	WIRING HARNESSES(FRONT & REAR)	4-N12	7250	QUARTER WINDOW & TRIMS			
4-N07	6701	WIRING HARNESSES(ENGINE & T/MISSION)	4-E13	7800	SPOILERS & RELATED PARTS			
4-D08	6702	WIRING HARNESSES(DASHBOARD)	4-C14	7900	ACCESSORIES			

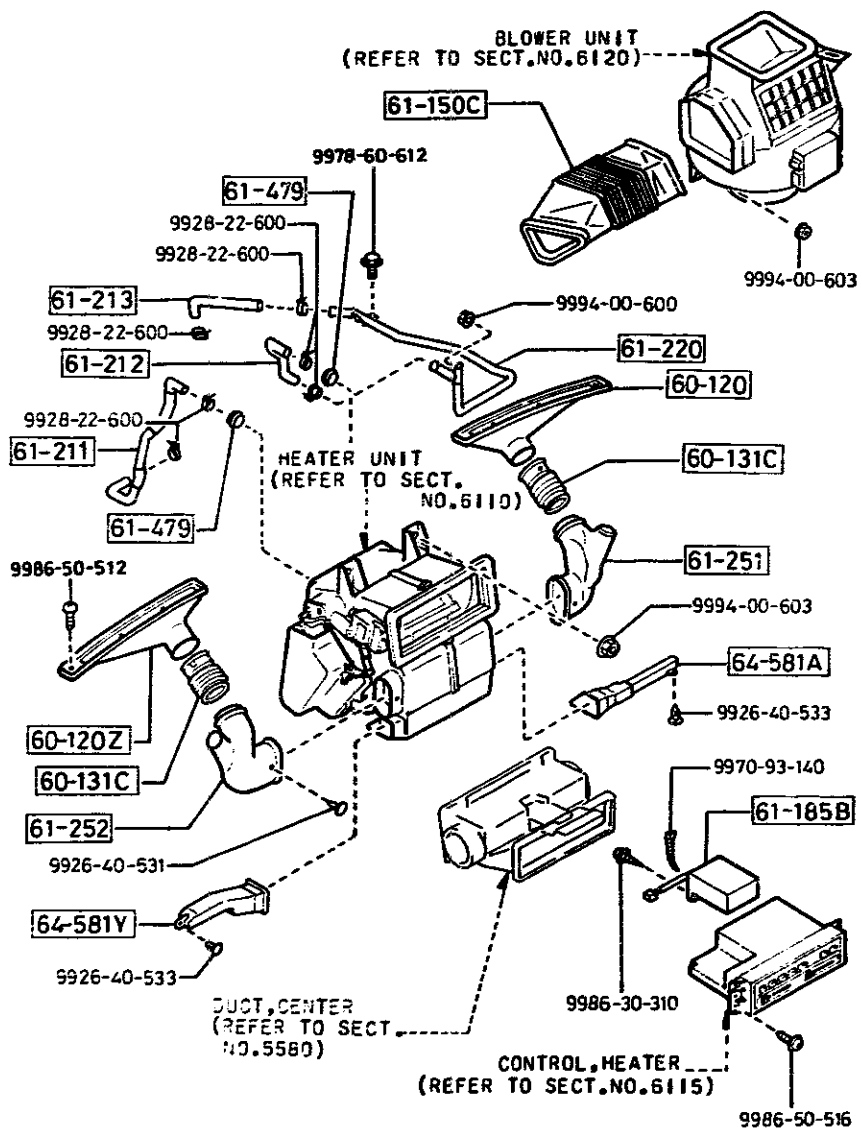

PART NO.	QTY	MODEL/RESTRICTION	MODEL/RESTRICTION	MODEL/RESTRICTION	FROM-TO
60-120		NOZZLE(R),DEFROSTER			
FB01-60-121B	1				
60-120Z		NOZZLE(L),DEFROSTER			
FB01-60-141B	1				
60-131C		DUCT,DEFROSTER			
FB01-61-256	2				
61-150C		DUCT,AIR			
FB01-61-150A	1	(W/O AIR CON.)			
61-185B		BOX,AMP-HEATER CONTR			
FB01-61-185A AN(FB01-61-185B)	1				-9421
FB01-61-185B	1				9421-
61-211		HOSE NO.1,WATER			
FB01-61-211C	1	((W/O TURBO)>(AT)) (TURBO)			
FB03-61-211	1	((W/O TURBO)>(MT))			
61-212		HOSE NO.2,WATER			
FB01-61-212B	1				
61-213		HOSE NO.3,WATER			
FB01-61-213	1				
61-220		PIPE,HEATER			
FB01-61-220C	1	(W/O TURBO)			
FB44-61-220A	1	(TURBO)			
61-251		HOSE,DEFROSTER			
FB01-61-251A	1				
61-252		HOSE,DEFROSTER			
FB01-61-252	1				
61-479		GROMMET			
8871-61-219A	2				
9421 FC3MNR-706548					

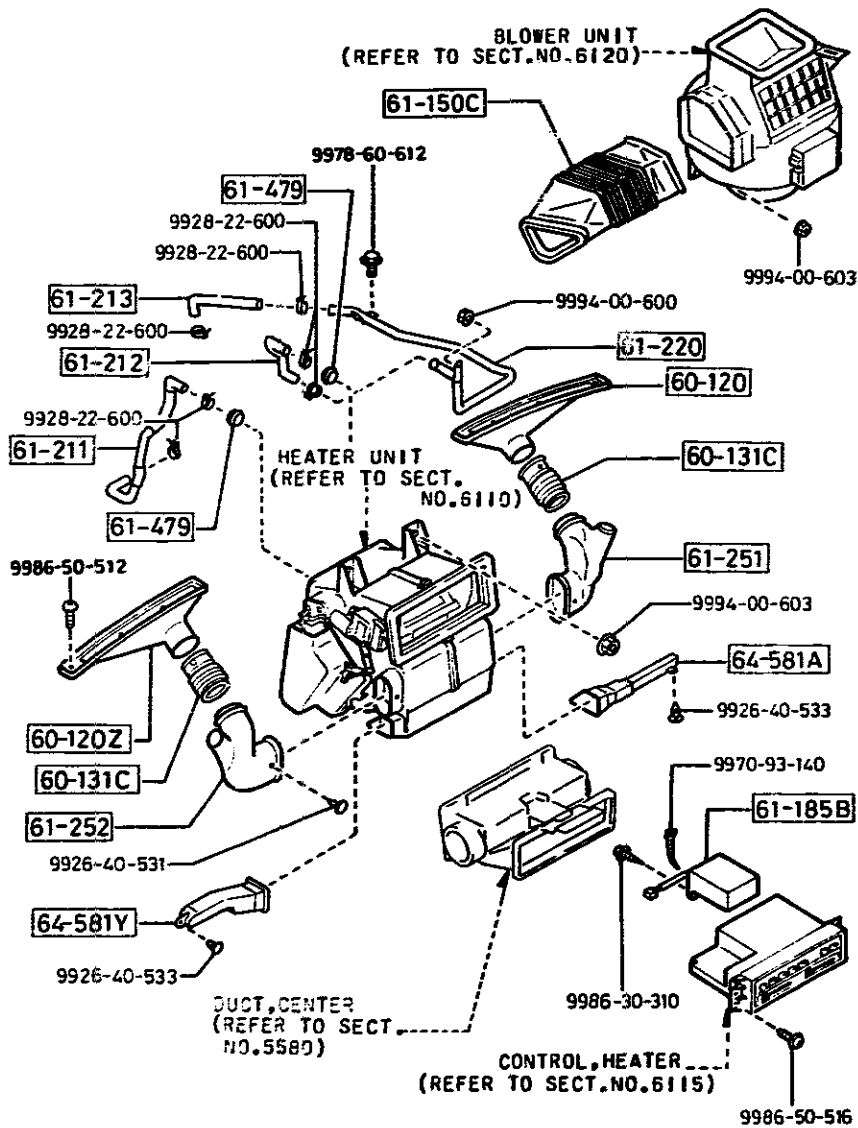

PART NO.	QTY	MODEL/RESTRICTION	MODEL/RESTRICTION	MODEL/RESTRICTION	FROM-TO
64-581A		DUCT(R), SHOWER			
FB02-61-155C	1				
02		FD8 BLACK			
19		FEO RED			
48		FD9 BLUE			
64-581Y		DUCT(L), SHOWER			
FB02-61-156B	1				

4-D-3

6110 HEATER UNIT COMPONENTS

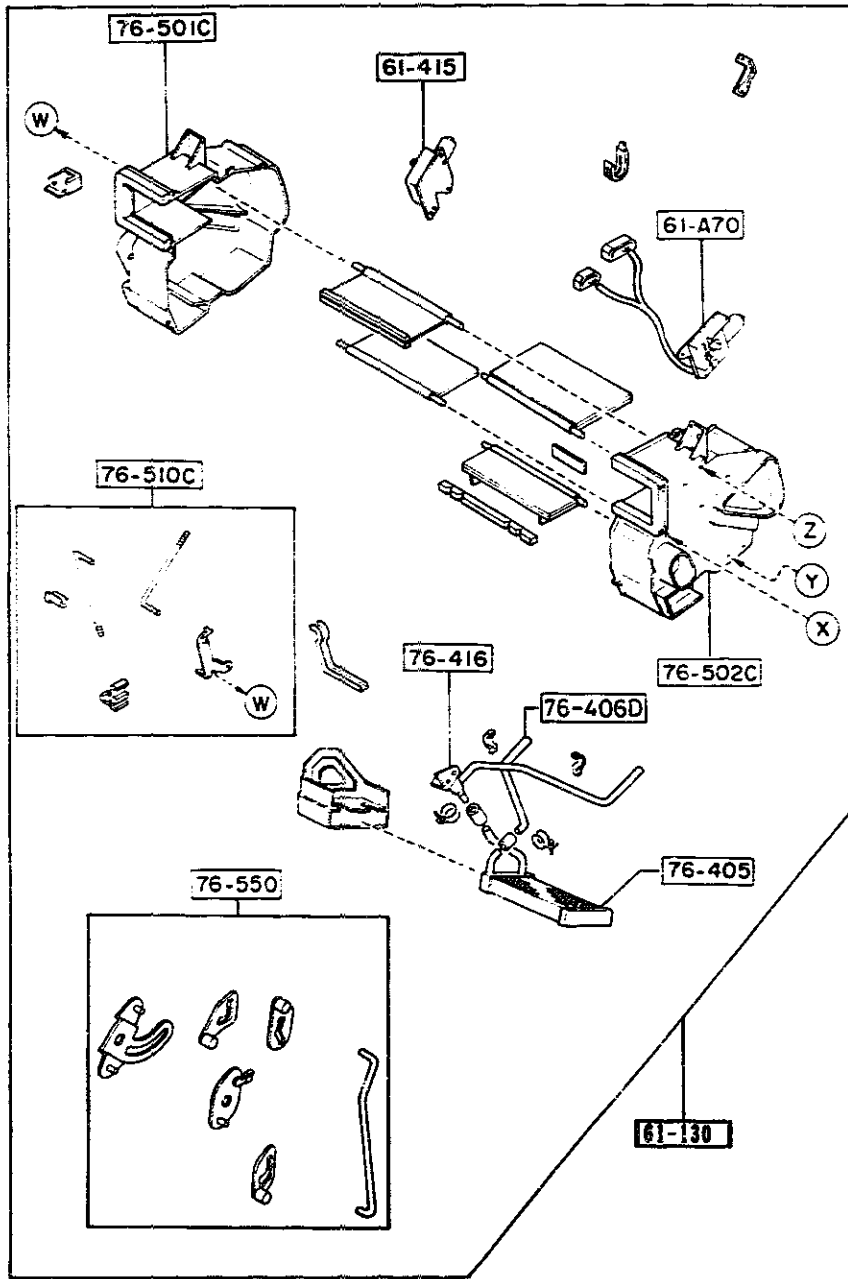

6110 -1 * HEATER UNIT COMPONENTS

PART NO.	QTY	MODEL/RESTRICTION	MODEL/RESTRICTION	MODEL/RESTRICTION	FROM-TO
61-A70		ACTUATOR,MODE-HEATER UNIT			
FB01-61-A70A	1				
61-130		HEATER UNIT			
FB01-61-130A AN(FB01-61-130B)	1				-9801
FB01-61-130B AN(FB01-61-130C)	1				9801-9823
FB01-61-130C	1				9823-
61-415		ACTUATOR,TEMP			
FB01-61-A60A	1				
76-405		CORE,HEATER			
FB01-61-A10	1				
76-406D		PIPE,HEATER UNIT			
FB01-61-A15	1				
76-416		VALVE,WATER			
FB01-61-A40	1				
76-501C		CASE(R),HEATER UNIT			
FB01-61-A01	1				
76-502C		CASE(L),HEATER UNIT			
FB01-61-A02A	1				
76-510C		LINK SET,EMP			
FB01-61-A20	1				
76-550		LINK SET,MODE			
FB01-61-A30A	1				

9801 FC3NNN-800894
9823 FC3NNN-801679

CAT. AUFA02-06

1992-05

AUFA02

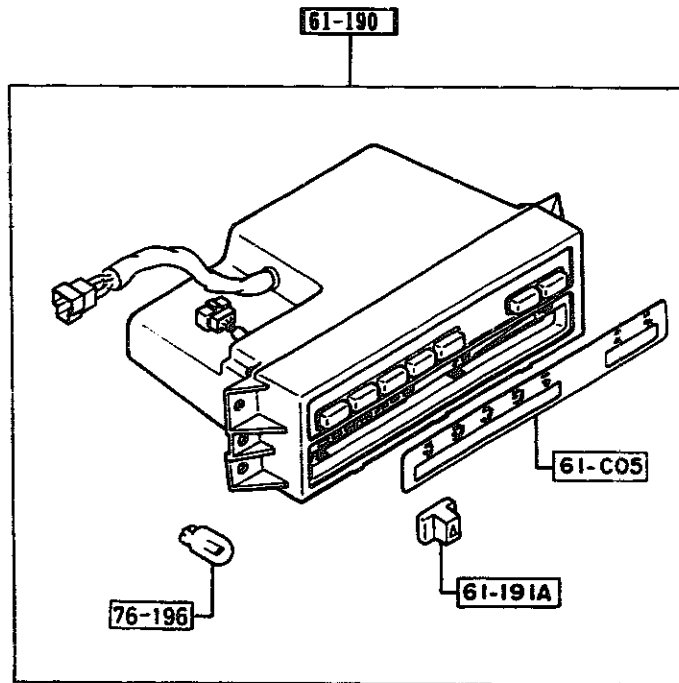

PART NO.	QTY	MODEL/RESTRICTION	MODEL/RESTRICTION	MODEL/RESTRICTION	FROM-TO
61-C05		FILM, PANEL-NO.1			
FC01-61-C05	1				
61-190		CONTROL, HEATER			
FC01-61-190 AN(FC01-61-190A)	1				-9421
FC01-61-190A AN(FC01-61-190B)	1				9421-9608
FC01-61-190B	1				9608-
61-191A		KNOB NO.1			
F803-61-191	2				
76-196		BULB			
FA55-76-196	2				

9421 FC3MXX-706548
9608 FC3MXX-708308

6120 HEATER BLOWER COMPONENTS

6120 -1 HEATER BLOWER COMPONENTS

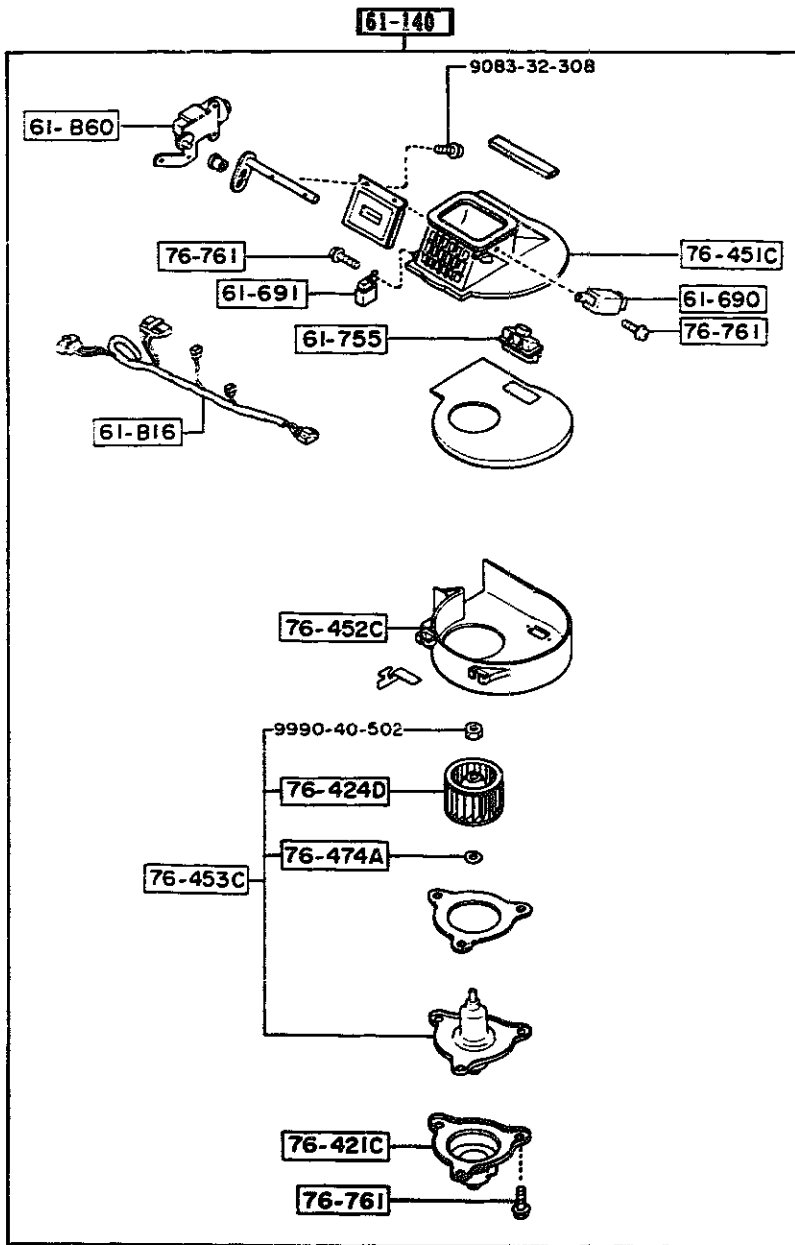

PART NO.	QTY	MODEL/RESTRICTION	MODEL/RESTRICTION	MODEL/RESTRICTION	FROM TO
61-816		HARNES, BLOWER UNIT			
FC01-61-816	1	((W/O TURBO))>(MT)			
FC07-61-816	1	((W/O TURBO))>(AT) (TURBO)			
61-860		ACTUATOR, RECYCLE & F RESH			
FB01-61-860	1				
61-140		BLOWER UNIT			
FC01-61-140	1	((W/O TURBO))>(MT)			
FC07-61-140	1	((W/O TURBO))>(AT) (TURBO)			
61-690		RELAY			
FB03-61-690	1	W/IG, RELAY BLOWER (W/O TURBO))>(AT) (TURBO)			
61-691		RELAY			
FB02-61-691	1				
61-755		TRANSISTOR, POWER			
FB01-61-755	1				
76-421C		COVER, MOTOR			
UB39-61-840	1				
76-424D		FAN, MOTOR			
8871-76-456	1				
76-451C		CASE (R), BLOWER			
FB01-61-801	1				
76-452C		CASE (L), BLOWER			
FB01-61-802A	1				
76-453C		MOTOR, BLOWER			
UB94-61-810	1				
76-474A		WASHER, PLAIN			
FA55-76-474	1				

6120 HEATER BLOWER COMPONENTS

6120 -2 * HEATER BLOWER COMPONENTS

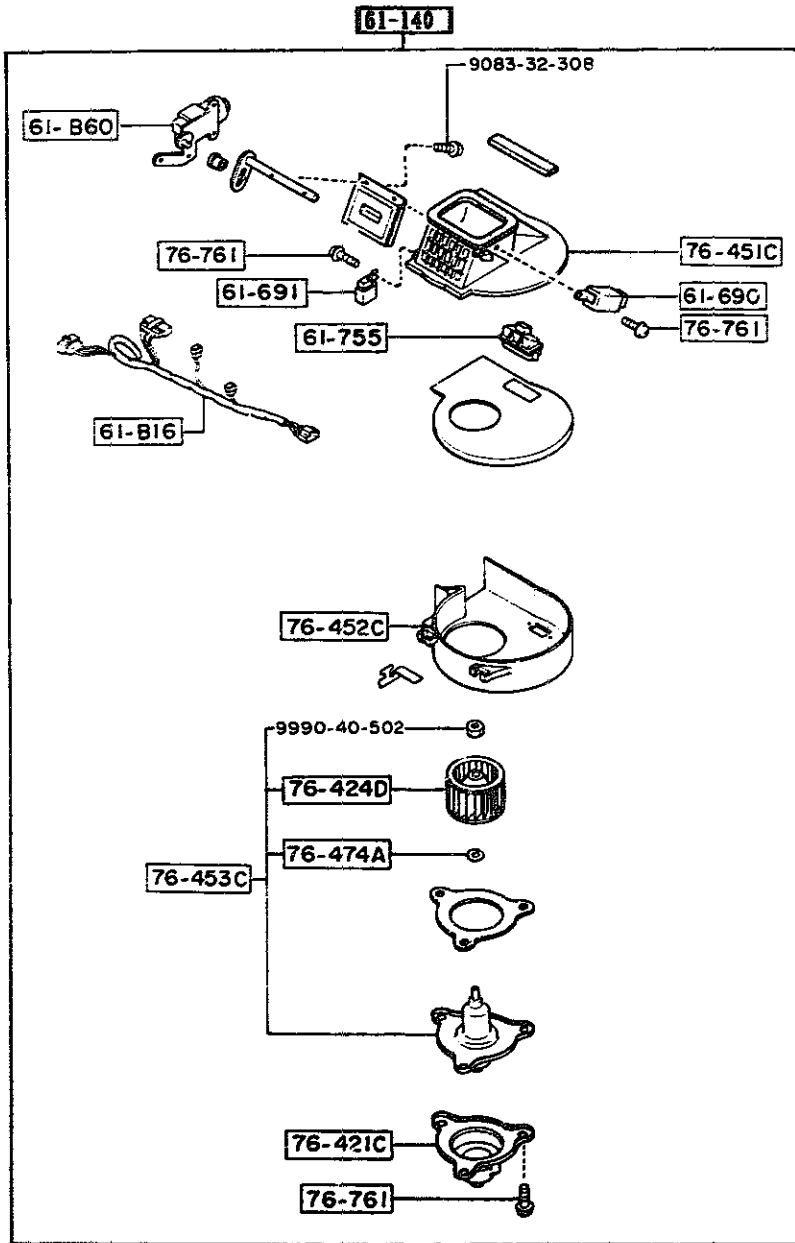

PART NO.	QTY	MODEL/RESTRICTION	MODEL/RESTRICTION	MODEL/RESTRICTION	FROM-TO
76-761		SCREW			
FA55-76-455	5				

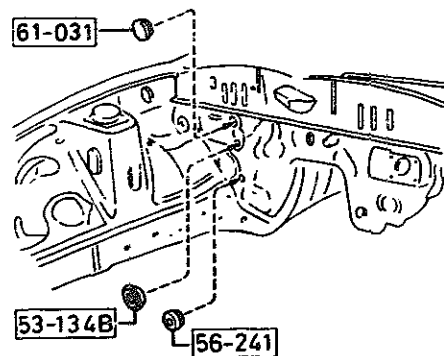

PART NO.	QTY	MODEL/RESTRICTION	MODEL/RESTRICTION	MODEL/RESTRICTION	FROM-TO
53-134B 0187-53-134	1	RUBBER,DUST SEAL			
56-241 0118-56-241	1	PLUG,DRAIN			
61-031 1708-61-031	1	PLUG,HOLE			

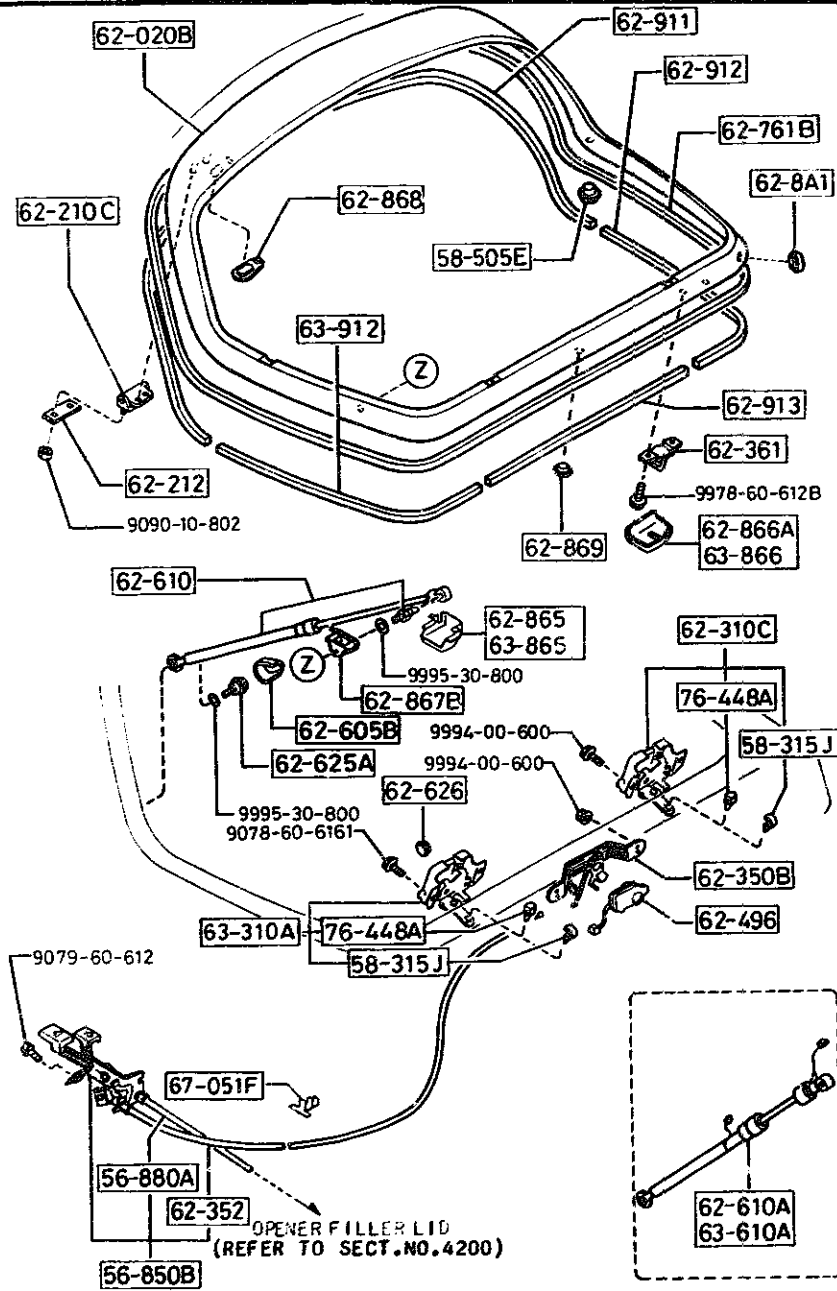

PART NO.	QTY	MODEL/RESTRICTION	MODEL/RESTRICTION	MODEL/RESTRICTION	FROM-TO
56-850B	1	OPENER, L/GATE & F/LID			-9804
FB02-56-850A (FB02-56-850E)	1				9804-
FB02-56-850E	1				
56-880A	1	CABLE, F/LID OPENER			
FB01-56-870B	1				
58-315J	2	CLIP			
H001-58-315	2				
58-505E	2	CAP			
B092-58-355	2				
62-020B	1	FRAME, GLASS HATCH			
FC01-62-020	1	W/D WIPER GTU, GTUS, (W/D RR WIPER)			
FC02-62-020	1	W/WIPER GXL, TURBO, (W/RR WIPER)			
62-210C	2	HINGE, GLASS HATCH			-9801
FB01-62-210A (FB01-62-210C)	2				9801-
FB01-62-210C	2				
62-212	2	GASKET, HINGE-LIFT GA TE			
FB01-62-212	2				
62-310C	1	LOCK(R), GLASS HATCH			
FB01-62-310D	1				
62-350B	1	UNIT, OPENER-GLASS HA TCH			-0403
FB01-62-350D (FB01-62-350E)	1				0403-
FB01-62-350E	1				
62-352	1	CABLE, OPENER			-9804
FB01-56-880B (FB01-56-880C)	1				9804-
FB01-56-880C	1	USA, (W/LID OPENER)			
9801 FC3MM-800894					
9804 FC3MM-801104					
0403 FC3MM-806598					

6230 LIFT GATE MECHANISMS (COUPE)

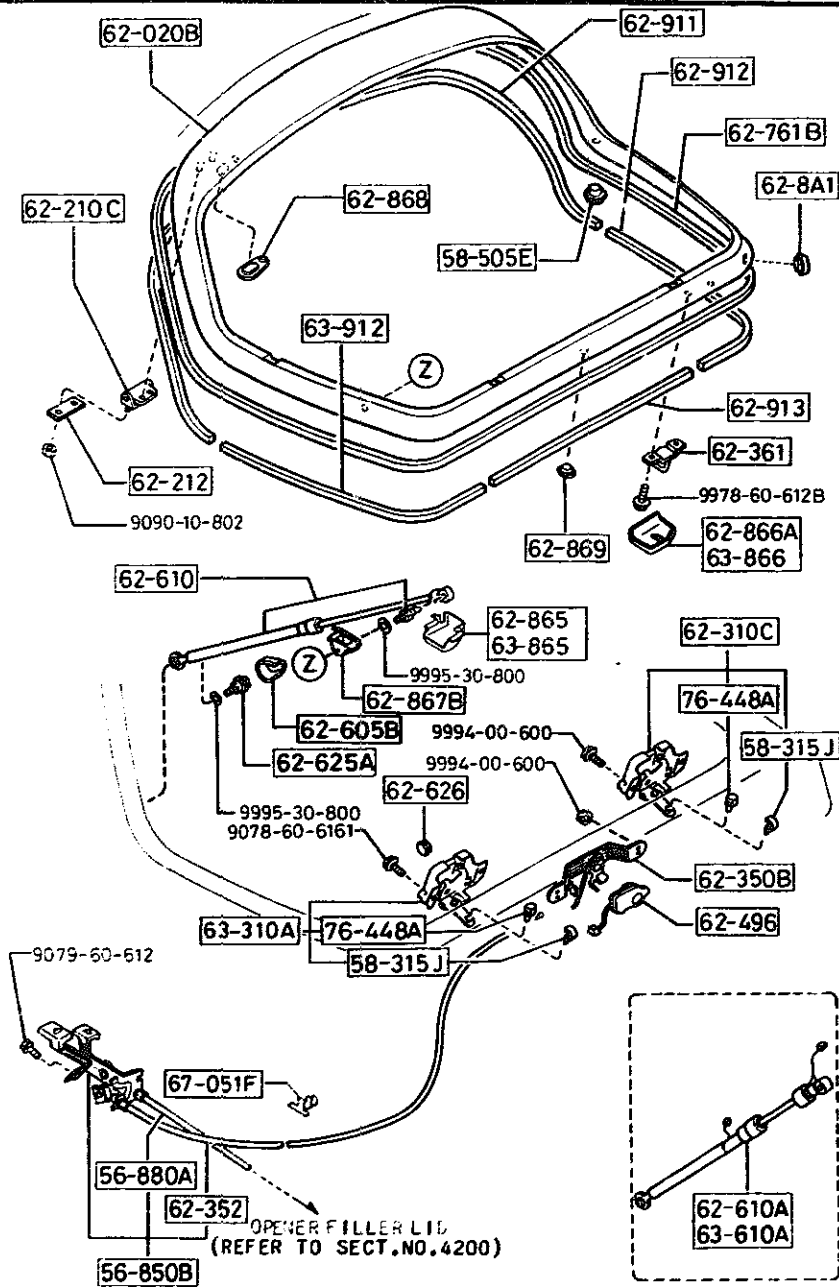

6230 -2 LIFT GATE MECHANISMS (COUPE)

PART NO.	QTY	MODEL/RESTRICTION	MODEL/RESTRICTION	MODEL/RESTRICTION	FROM-TO
62-361		STRIKER, LOCK			
FB01-62-361B	2				
62-496		SWITCH, LOCK CYLINDER			
FB02-62-496A	1	USA, (W/BURGLAR ALARM)			
62-605B		COVER, DAMPER STAY			
FB01-62-615	2				
62-610		STAY, DAMPER			
88F1-62-620A A (88F1-62-620B)	1	W/O WIPER & R. LAMP H			-9201
88F1-62-620B	1	(FOR LEFT) (W/O A.A. SUSP)			9201-
62-610A		STAY (R), DAMPER			
88F7-62-620	1				
62-625A		BOLT, BRACKET-STAY DAMPER			
FB01-62-625	2				
62-626		PLUG, HOLE-LAMP & WIP HARN			
FB01-62-626	1	GXL, TURBO, (W/RR WIPER)			
62-761B		WEATHERSTRIP, GLASS HATCH			
FB01-62-761C	1				
62-8A1		PLUG, HOLE-HATCH FRAME LOW			
FB01-62-8A1A	2				
62-865		COVER 'A' (R), FRAME-G. HATCH			
FB01-62-865A	1				
62-866A		COVER 'B' (R), FRAME-G. HATCH			
FB01-62-866B	1				
62-867B		COVER, BRACKET-DAMPER STAY			
FB01-62-867A	2				
9201 FCS***-701886					

AUFA02

CAT. AUFA02-06

1992-05

4-K 3

6230 LIFT GATE MECHANISMS
(COUPE)

6230 -3 * LIFT GATE MECHANISMS
(COUPE)

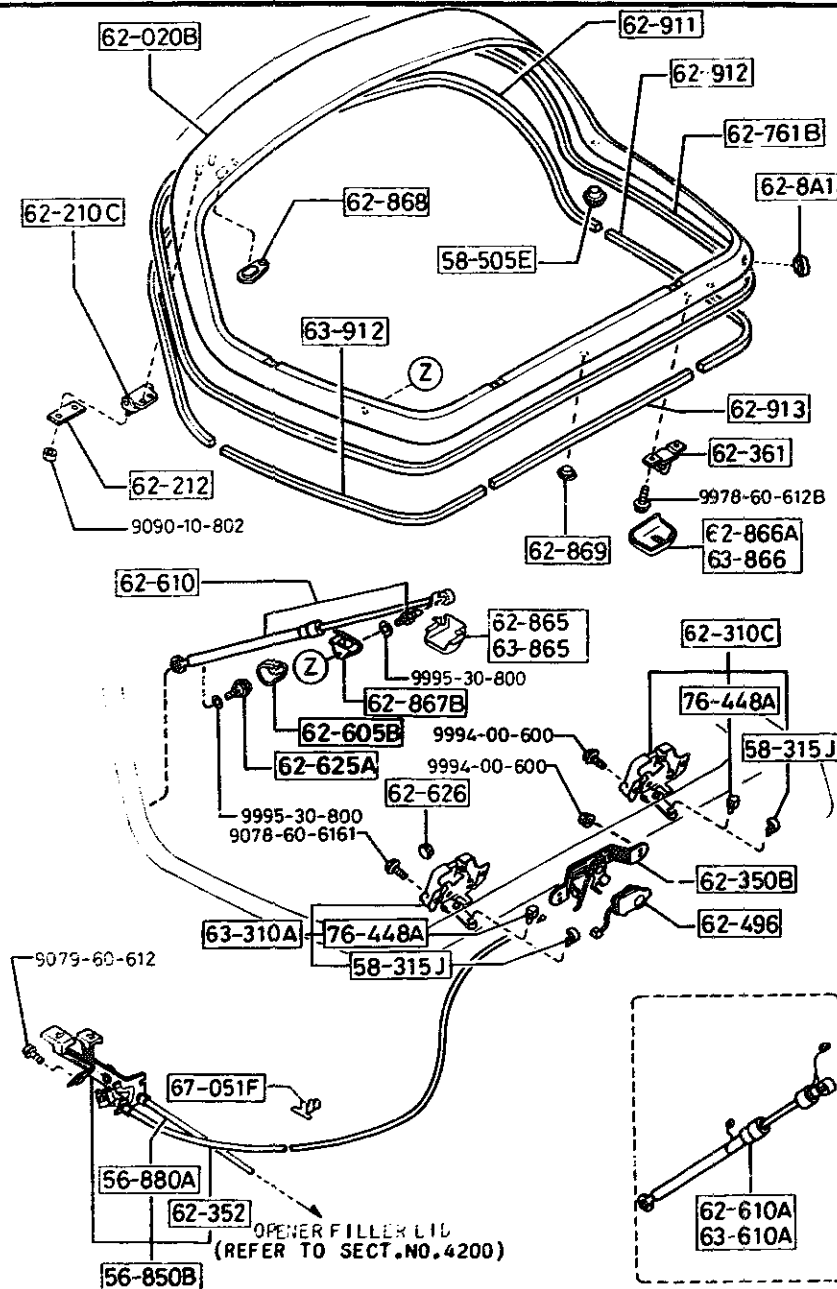

PART NO.	QTY	MODEL/RESTRICTION	MODEL/RESTRICTION	MODEL/RESTRICTION	FORM-TO
62-868		PLUG, HOLE-HATCH FRAME UP.			
FB01-62-868	2				
62-869		PLUG, HOLE-HATCH FRAME LOW			
FB01-62-869	1				
62-911		WELT, SEAMING-GLS HATCH UP			
FB01-62-911C	1				
62-912		WELT (R), SEAMING-GLS HATCH			
FB01-62-912B	1				
62-913		WELT, SEAMING-GLS HATCH LOW GTU, GTUS, (W/O RR WIPER)			
FB01-62-913C	1				
62-913B		GXL, TURBO, (W/RR WIPER)			
FB02-62-913B	1				
63-310A		LOCK (L), GLASS HATCH			
FB01-63-310E	1				
63-610A		STAY (L), DAMPER (A.A. SUSP)			
8BF3-63-620	1				
63-865		COVER 'A' (L), FRAME-G HATCH			
FB01-63-865A	1				
63-866		COVER 'B' (L), FRAME-G HATCH			
FB01-63-866B	1				
63-912		WELT (L), SEAMING-GLS HATCH GTU, GTUS, (W/O RR WIPER)			
FB01-63-912C	1				
63-912B		GXL, TURBO, (W/RR WIPER)			
FB02-63-912B	1				
67-051F		CLIP			
FB01-67-051	1				
76-448A		CLIP			
G030-76-448	2				

AUFA02

CAT. AUFA02-06

1992-05

6300 WINDOW GLASSES
(COUPE)

6300 -1 * WINDOW GLASSES
(COUPE)

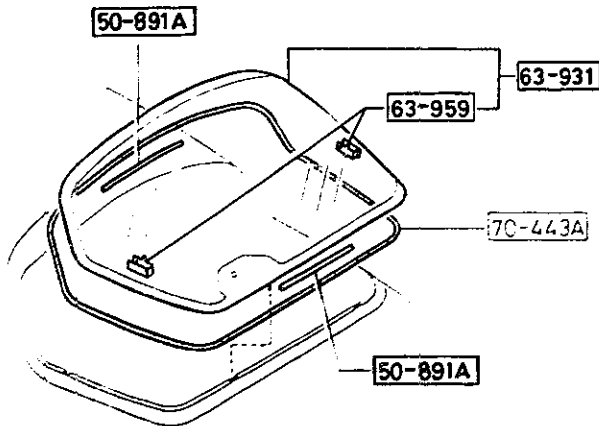
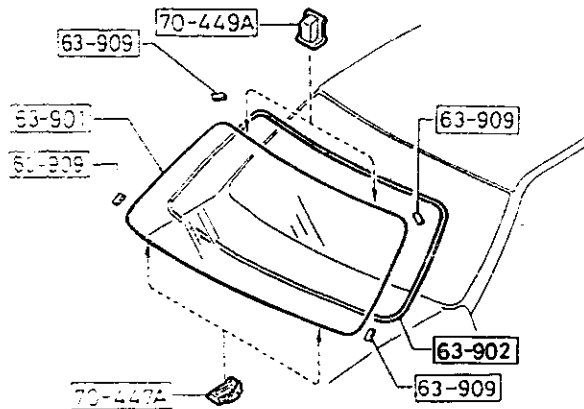

PART NO.	QTY	MODEL/RESTRICTION	MODEL/RESTRICTION	MODEL/RESTRICTION	FROM-TO
50-891A		SPACER, WINDOW			
FB01-50-891	2				
63-901		GLASS, WINDSHIELD			
FC02-63-901	1				
63-902		DAM, FRT. WSHLD GLASS			
FB01-50-895A	1				
63-909		SPACER			
8182-63-903	4				
63-931		GLASS, BACK WINDOW			
FB01-63-930	1	BLUE GTU, GTUS, (W/D RR WIPER)			
FB02-63-930	1	BLUE GXL, TURBO, (W/RR WIPER)			
63-959		TERMINAL, BACK WINDOW GLAS			
FB01-63-959	2				
70-443A		DAM, RR WINDOW GLASS			
FB01-50-896	1				
70-447A		SPACER 'A'			
FB01-50-893	2				
70-449A		SPACER 'C'			
FB01-50-897	2				

6300A WINDOW GLASSES
(CONVERTIBLE)

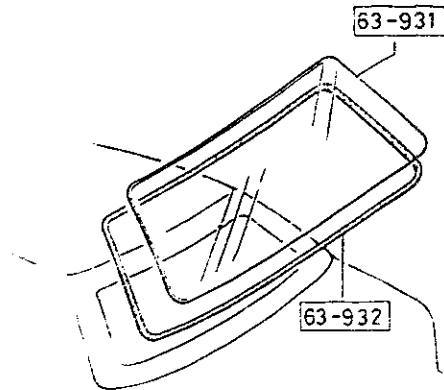
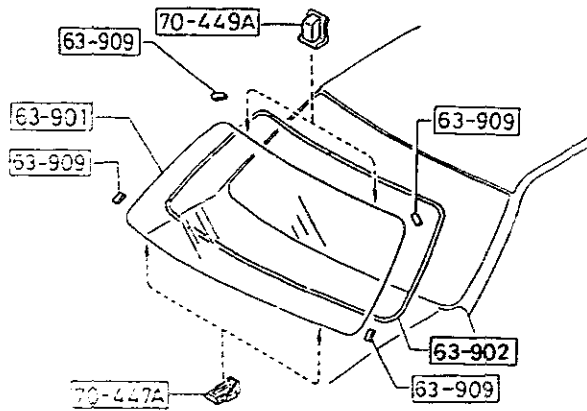

6300A -1 * WINDOW GLASSES
(CONVERTIBLE)

PART NO.	QTY	MODEL/RESTRICTION	MODEL/RESTRICTION	MODEL/RESTRICTION	FROM-TO
63-901		GLASS, WINDSHIELD			
FB03-63-901E	1				
63-902		DAM, FRT. WSHLD GLASS			
FB67-50-894	1				
63-909		SPACER			
8182-63-905	4				
63-931		GLASS, BACK WINDOW			
FB67-63-931A	1	BLUE			
63-932		WEATHERSTRIP, RR. WIND			
FB67-63-932B	1				
70-447A		SPACER 'A'			
FB01-50-893	2				
70-449A		SPACER 'C'			
FB01-50-897	2				

SECTION NAME INDEX (BODY) 2/2

LO.NO	SEC.NO	SECTION NAME	LO.NO	SEC.NO	SECTION NAME	LO.NO	SEC.NO	SECTION NAME
4-C03	6100	HEATER	4-E08	6703	WIRING HARNESSSES(DOOR,FLOOR/CEILING)			
4-E03	6110	HEATER UNIT COMPONENTS	4-G08	6704	WIRING HARNESS CLAMPS			
4-F03	6115	HEATER CONTROLS COMPONENTS	4-J08	6720	WINDSHIELD WASHER (1.5L & 2.5L)			
4-G03	6120	HEATER BLOWER COMPONENTS	4-L08	6720 A	WINDSHIELD WASHER (5.7L)			
4-I03	6130	AIR CONDITIONER	4-N08	6730	WINDSHIELD WIPERS			
4-J03	6230	LIFT GATE MECHANISMS (COUPE)	4-C09	6740	WIPER MOTOR COMPONENTS(FRONT)			
4-M03	6300	WINDOW GLASSES (COUPE)	4-D09	6750	WINDOW WIPER & WASHER (REAR)			
4-N03	6300A	WINDOW GLASSES (CONVERTIBLE)	4-G09	6760	WINDOW WIPER MOTOR COMPONENTS (REAR)			
4-C04	6330	SUNROOF (COUPE)	4-H09	6800	CEILING TRIMS (COUPE)			
4-G04	6330A	SUNROOF (CONVERTIBLE)	4-J09	6800A	CEILING TRIMS (CONVERTIBLE)			
4-M04	6600	SWITCHES & RELAYS (ENGINE)	6810	ROLLEBAR (CONVERTIBLE)				
4-G05	6610	DASHBOARD SWITCHES	4-N09	6820	PILLAR TRIMS (COUPE)			
4-H05	6611	COMBINATION SWITCH	4-F10	6820A	PILLAR TRIMS (CONVERTIBLE)			
4-I05	6612	CLUSTER SWITCH	4-G10	6840	TRIMS & SCUFF PLATES (COUPE)			
4-L05	6615	POWER WINDOW SWITCHES	4-L10	6840A	TRIMS & SCUFF PLATES (CONVERTIBLE)			
4-M05	6630	RELAYS & UNIT (BODY)	4-N10	6845	STRAGE BOX (COUPE)			
4-D06	6635	DOOR SWITCH & HORNS			(GXL,TURBO)			
4-E06	6640	AUTO CRUISE CONTROL SYSTEM	4-D11	6860	FLOOR MATS & PADS (COUPE)			
4-F06	6680	AUDIO SYSTEMS (RADIO & TAPE DECK) (COUPE)	4-K11	6860A	FLOOR MATS & PADS (CONVERTIBLE)			
4-K06	6680 A	AUDIO SYSTEMS (RADIO & TAPE DECK) (CONVERTIBLE)	4-C12	6870	SERVICE TOOLS			
4-M06	6682	AUDIO SYSTEMS (ANTENNA & SPEAKER) (COUPE)	4-D12	6900	VISORS,ASSIST HANDLES & MIRRORS (COUPE)			
4-D07	6682 A	AUDIO SYSTEMS (ANTENNA & SPEAKER) (CONVERTIBLE)	4-H12	6900A	VISORS,ASSIST HANDLES & MIRRORS (CONVERTIBLE)			
4-G07	6684	AUDIO SYSTEMS(NOISE SUPPRESSOR & EARTH CORD)	4-K12	6930	CAUTION PLATES & LABELS			
4-H07	6700	WIRING HARNESSSES(FRONT & REAR)	4-N12	7250	QUARTER WINDOW & TRIMS			
4-N07	6701	WIRING HARNESSSES(ENGINE & TRANSMISSION)	4-E13	7800	SPOILERS & RELATED PARTS			
4-D08	6702	WIRING HARNESSSES(DASHBOARD)	4-C14	7900	ACCESSORIES			

CATLOG-NO= AUFA02-06

DATE 1992-05

6330 SUNROOF (COUPE)

6330 -1 SUNROOF (COUPE)

(INSTALLED IN THE GLOVE BOX)

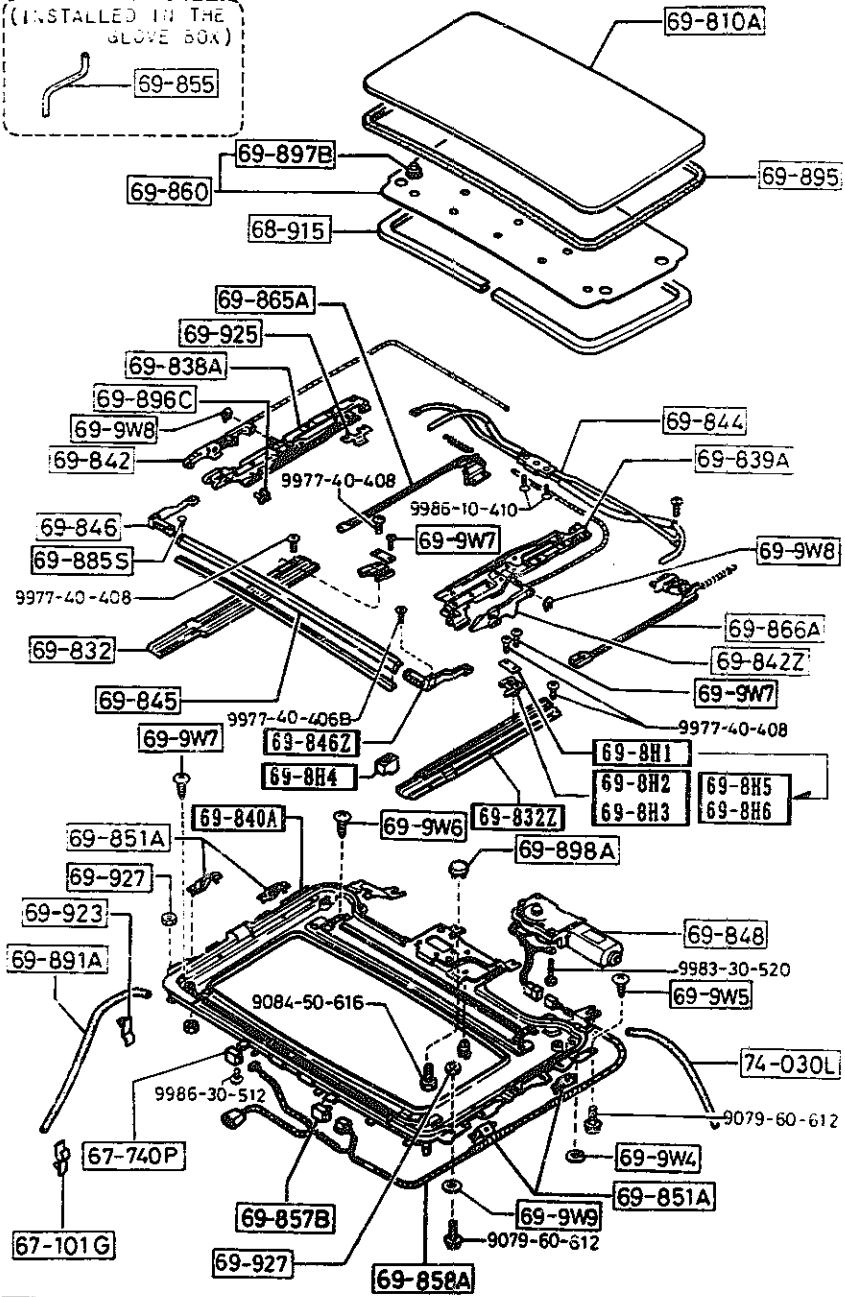

PART NO.	QTY	MODEL/RESTRICTION	MODEL/RESTRICTION	MODEL/RESTRICTION	FROM-TO
67-101G		CLIP, DRAIN HOSE-FRONT			
FB03-69-928	4				
67-740P		RELAY, SLIDE ROOF			
FB03-69-873	1				
68-915		WELT, SEAMING			
FB03-69-915A	1				
02		F08 BLACK			
19		F09 RED			
48		FD9 BLUE			
69-8H1		CLIP, TUBE-UPPER			
FB03-69-8H1	2				-9501
69-8H2		CLIP(R), TUBE-LOWER			
FB03-69-8H2	1				-9501
A (FB03-69-8H2A)					
FB03-69-8H2A	1				9501-
69-8H3		CLIP(L), TUBE-LOWER			
FB03-69-8H3	1				-9501
A (FB03-69-8H3A)					
FB03-69-8H3A	1				9501-
69-8H4		GASKET, TUBE-CLIP			
FB03-69-8H4	2				
69-8H5		CLIP(R), TUBE-UPPER			
FB03-69-8H5	1				9501-
69-8H6		CLIP(L), TUBE-UPPER			
FB03-69-8H6	1				9501-
69-810A		PANEL, SLIDING ROOF			
FB03-69-810H	1				
69-832		RAIL(R), GUIDE			
FB03-69-832A	1				-9501
A (FB03-69-832B)					
FB03-69-832B	1				9501-0701
9501 FC3***-707092					
0701 FC3***-807120					

AUFA02

CAT. AUFA02-06

1992-05

(INSTALLED IN THE GLOVE BOX)

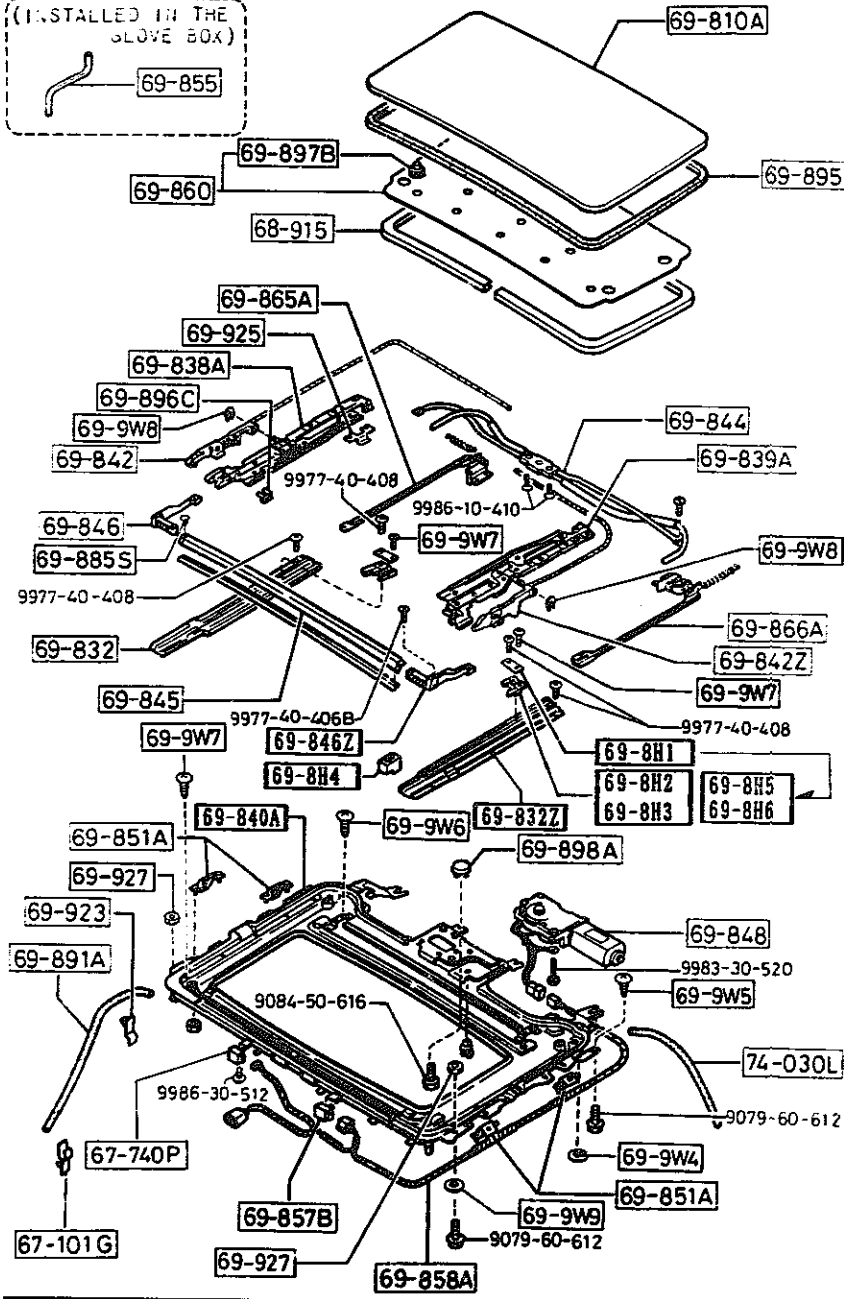

PART NO.	QTY	MODEL/RESTRICTION	MODEL/RESTRICTION	MODEL/RESTRICTION	FROM-TO
CONT'D					
A (FB03-69-832C)					
FB03-69-832C	1				0701-
69-832Z		RAIL(L),GUIDE			
FB03-69-833A	1				-9501
A (FB03-69-833B)					
FB03-69-833B	1				9501-0701
A (FB03-69-833C)					
FB03-69-833C	1				0701-
69-838A		PANEL(R),LOWER-SLDG ROOF			
FB03-69-838C	1				
69-839A		PANEL(L),LOWER-SLDG ROOF			
FB03-69-839C	1				
69-840A		FRAME,SLIDING ROOF			
FB03-69-831J	1				
69-842		GUIDE(R),REAR			
FB03-69-842A	1				
69-842Z		GUIDE(L),REAR			
FB03-69-843A	1				
69-844		UNIT,DRIVE			
FB03-69-844A	1				
69-845		DEFLECTOR			
FB03-69-845	1				
69-846		LINK(R),DEFLECTOR			
FB03-69-846B	1				
69-846Z		LINK(L),DEFLECTOR			
FB03-69-847B	1				
69-848		MOTOR,SLIDING ROOF			
FB03-69-848A	1				-0110
A (FB03-69-848B)					
FB03-69-848B	1				0110-
9501 FC3***-707092					
0110 FC3***-805539					
0701 FC3***-807120					

6330 SUNROOF
(COUPE)

6330 -3 SUNROOF
(COUPE)

FPOM-T0

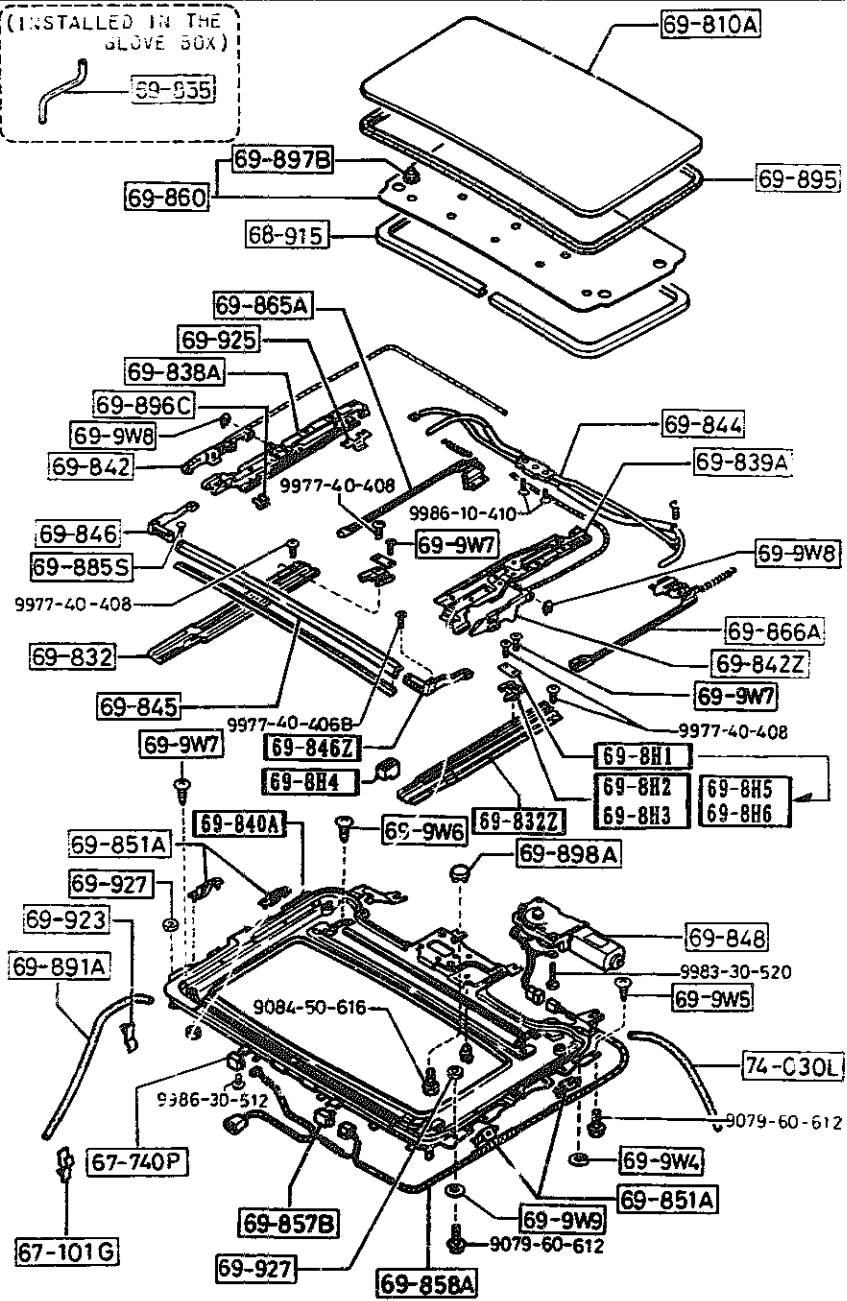

PART NO.	QTY	MODEL/RESTRICTION	MODEL/RESTRICTION	MODEL/RESTRICTION	FPOM-T0
69-851A		BRACKET, SET-S. ROOF FRAME			
FB03-69-849	4				
69-855		HANDLE, SLIDING ROOF			
FB03-69-982	1				
69-857B		RELAY, SLIDING ROOF			
FB03-69-857A	1				
69-858A		HARNES, SLIDING ROOF			
FB03-69-858	1				
69-860		TRIM, SLIDING ROOF			
FB03-69-860C	1				
02		FD8 BLACK			
19		FED RED			
48		FD9 BLUE			
69-865A		SHUTTING(R), SLIDING ROOF			
FB03-69-865	1				
69-866A		SHUTTING(L), SLIDING ROOF			
FB03-69-866	1				
69-885S		CLIP, DEFLECTOR LINK			
FB03-69-885	2				
69-891A		HOSE, DRAIN-SUN ROOF FRONT			
FB03-69-891A	2				
69-895		WEATHERSTRIP, S/ROOF			
FB03-69-895B	1				
69-896C		SHIM, LOWER PANEL FRONT			
FB03-69-896A	6				
69-897B		FASTENER, TRIM-SLIDE ROOF			
FB03-69-897	6				
69-898A		COVER, MOTOR-SLIDING ROOF			

-9801

9801-9823

9223-

1992-05

AUFA02

CAT. AUFA02-06

1992-05

6330 SUNROOF
(COUPE)

6330 -4 * SUNROOF
(COUPE)

FROM-TO

(INSTALLED IN THE
SLOVE BOX)

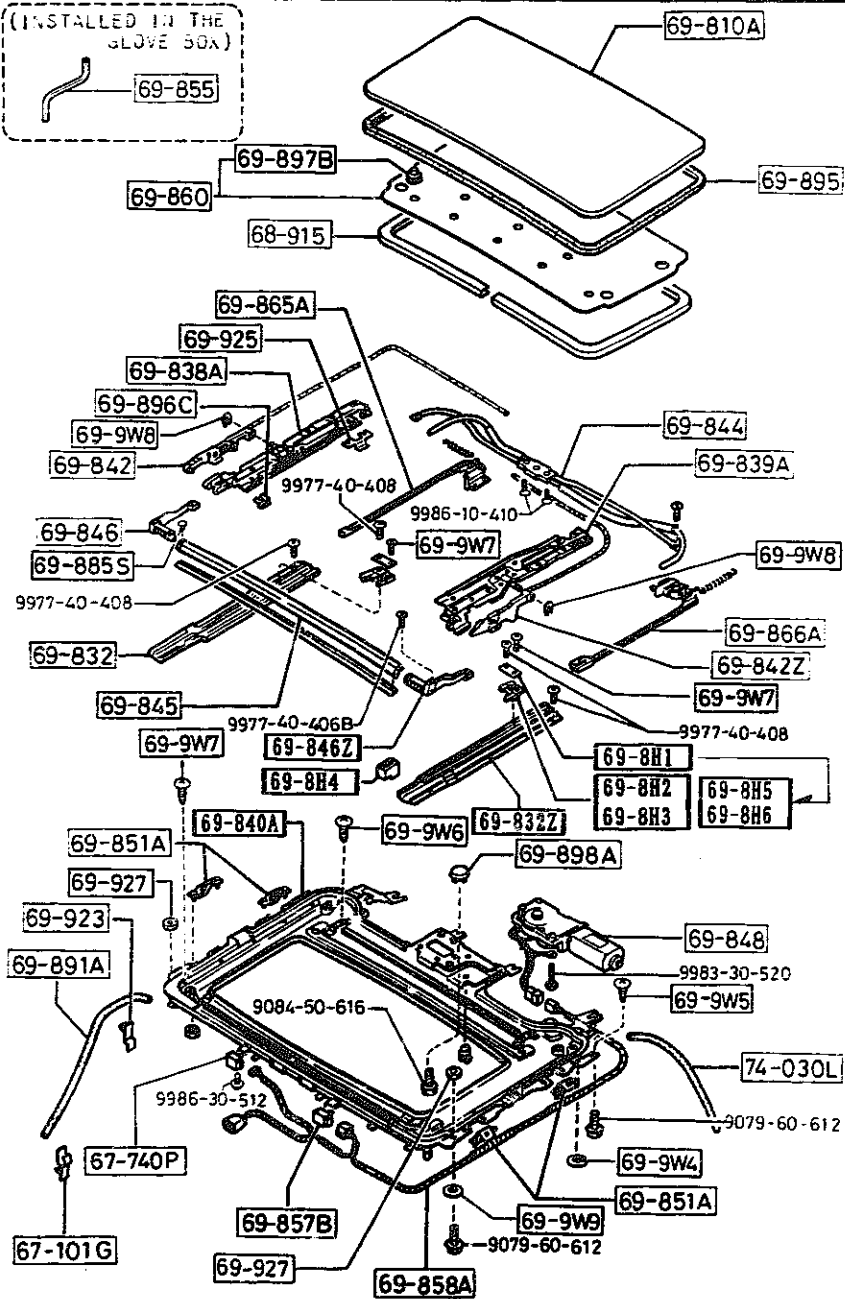

PART NO.	QTY	MODEL/RESTRICTION	MODEL/RESTRICTION	MODEL/RESTRICTION	FROM-TO
CONT'D					
FB03-69-898	1				
02		FD8 BLACK			
19		FE0 RED			
48		FD9 BLUE			
69-9W4		RING 'A', SNAP-LOWER U NIT			
FB03-69-9W4	4				
69-9W5		SCREW, TAPPING-LOWER UNIT			
FB03-69-9W5	2				
69-9W6		SCREW 'A', LOWER UNIT- S/R			
FB03-69-9W6	4				
69-9W7		SCREW 'B', LOWER UNIT- S/R			
FB03-69-9W7	4				
69-9W8		RING 'B', SNAP-LOWER U NIT			
FB03-69-9W8	2				
69-9W9		WASHER, LOWER UNIT-S/ ROOF			
FB03-69-9W9	8				
69-923		CLIP, DRAIN HOSE-SUN ROOF			
FB03-69-923	2				
69-925		SHIM, LOWER PANEL REA R			
FB03-69-925A	4				
69-927		NUT, ADJUST-S/ROOF FR AME			
FB03-69-927	4				
74-030L		HOSE, DRAIN-REAR			
FB03-69-892A	2				

-9421

421-9608

608-

1992-05

AUFA02

CAT. AUFA02-06

1992-05

6330A SUNROOF (CONVERTIBLE)

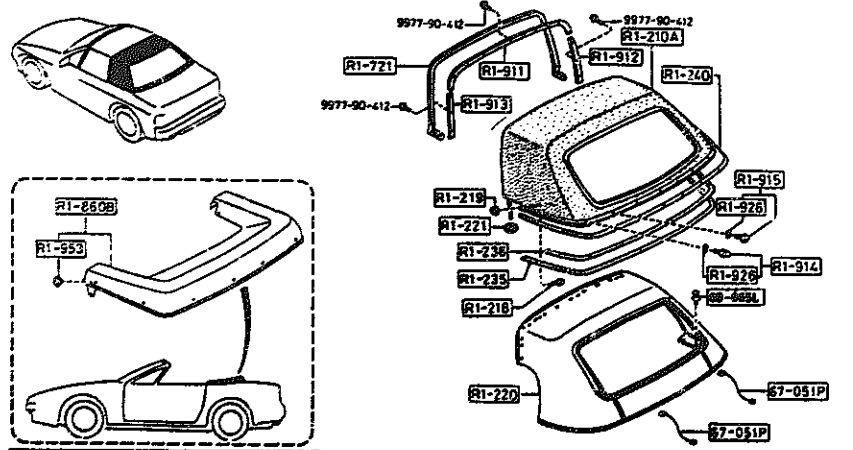
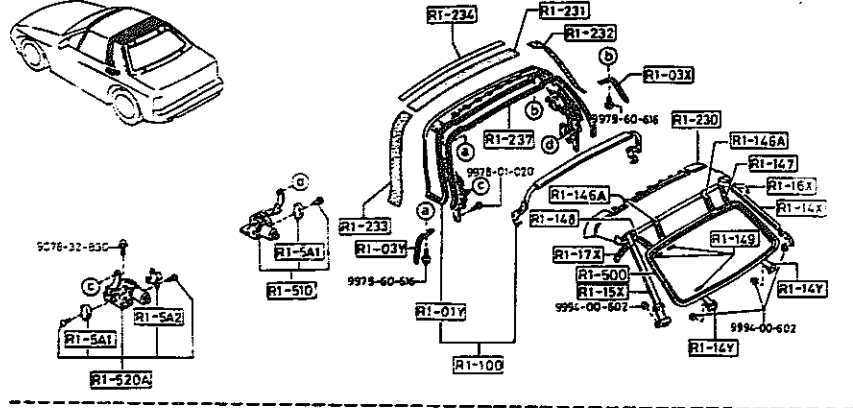
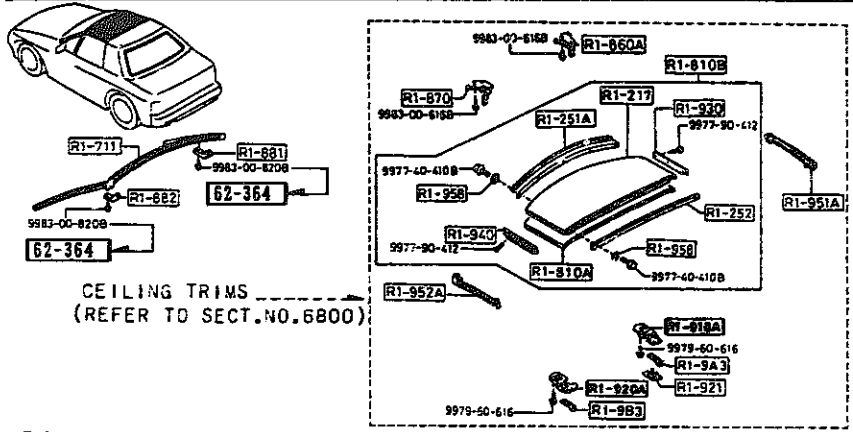

6330A -2 SUNROOF (CONVERTIBLE)

PART NO.	QTY	MODEL/RESTRICTION	MODEL/RESTRICTION	MODEL/RESTRICTION	FROM-TO
R1-217		FABRIC COVERING, ROOF PANEL			
FC33-R1-217	1				
R1-218		BOLT, HOOD OUTER			
FB67-R1-218	2				
R1-219		NUT, HOOD OUTER			
FB67-R1-219	2				
R1-220		LINER, HEAD-SOFT TOP			
FB67-R1-212C	1				
02		F08 FE1 BLACK			
48		F09 BLUE			
R1-221		PRUG, DRAIN HOSE-RR FLOOR			
FB67-R1-221	2				
R1-230		INSULATOR, TOP CEILING			
FB67-R1-213	1				
R1-231		PAD (CTR), SPACER-SOFT TOP			
FB67-R1-231	1				
R1-232		PAD (R), SPACER-SOFT TOP			
FB67-R1-232	1				
R1-233		PAD (L), SPACER-SOFT TOP			
FB67-R1-233	1				
R1-234		PLATE, FRONT-SOFT TOP			
FB67-R1-234	1				
R1-235		TAPE 'A', SEAL-TOP FABRIC			
FB67-R1-235	1				
R1-236		TAPE 'B', SEAL-TOP FABRIC			
FB67-R1-236	1				
R1-237		PROTECTOR, FORMING BAR			
FB67-R1-237A	1				

6330A SUNROOF (CONVERTIBLE)

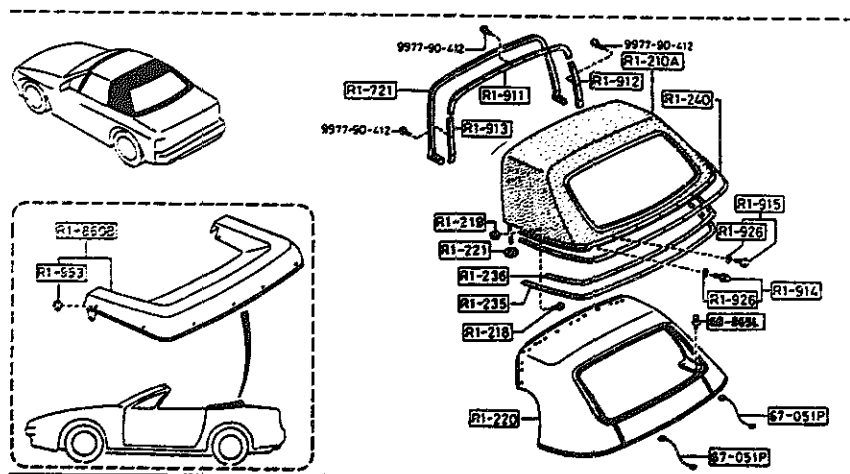
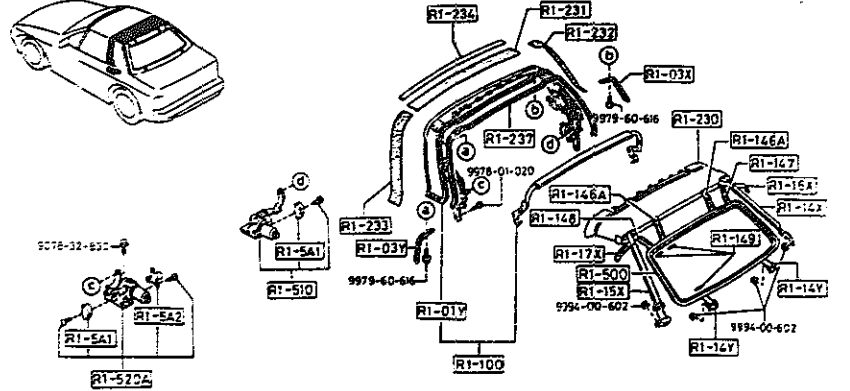
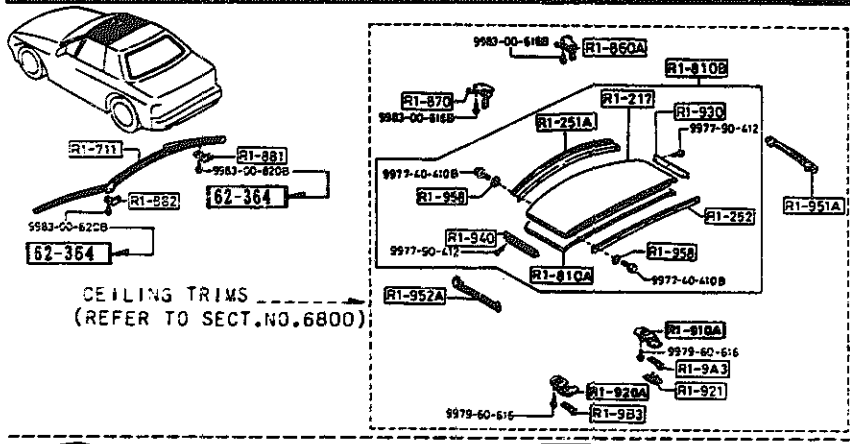

6330A -4 SUNROOF (CONVERTIBLE)

PART NO.	QTY	MODEL/RESTRICTION	MODEL/RESTRICTION	MODEL/RESTRICTION	FROM-TO
RI-860A		LOCK(R),TOP			
FB67-R1-860D	1				
RI-860B		BOOT, TOP			
FB67-R1-960G	1				
02		FD8 FE1 BLACK			
48		FD9 BLUE			
RI-870		LOCK(L),TOP			
FB67-R1-870D	1				
RI-881		STRIKER(R), LOCK-TOP			
FB67-R1-881C	1				
RI-882		STRIKER(L), LOCK-TOP			
FB67-R1-882C	1				
RI-9A3		BRACKET(R),HINGE-ROO F			
FB67-R1-9A3A	1				
RI-9B3		BRACKET(L),HINGE-ROO F			
FB67-R1-9B3A	1				
RI-910A		LOCK(R),HINGE-TOP			
FB67-R1-910H	1				
02		FD8 FE1 BLACK			
48		FD9 BLUE			
RI-911		RETAINER(C),FORMING BAR			
FB67-R1-911A	1				
RI-912		RETAINER(R),FORMING BAR			
FB67-R1-912A	1				
RI-913		RETAINER(L),FORMING BAR			
FB67-R1-913A	1				
RI-914		HOOK 'A',HOOD			
FB67-R1-91YC	8				

AUFAD2

CAT. AUFAD2-06

1992-05

6330A SUNROOF (CONVERTIBLE)

6330A -5 SUNROOF (CONVERTIBLE)

FROM TO

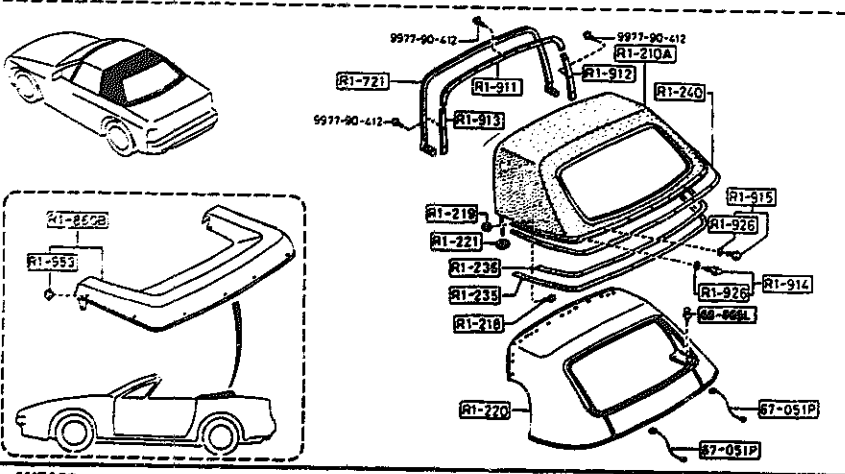
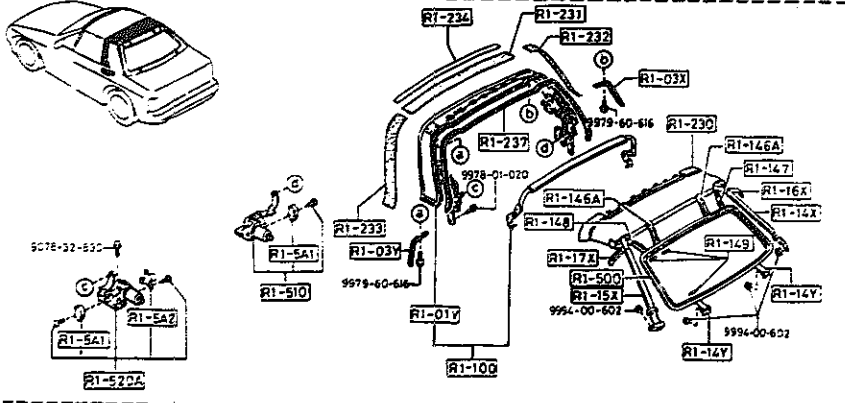
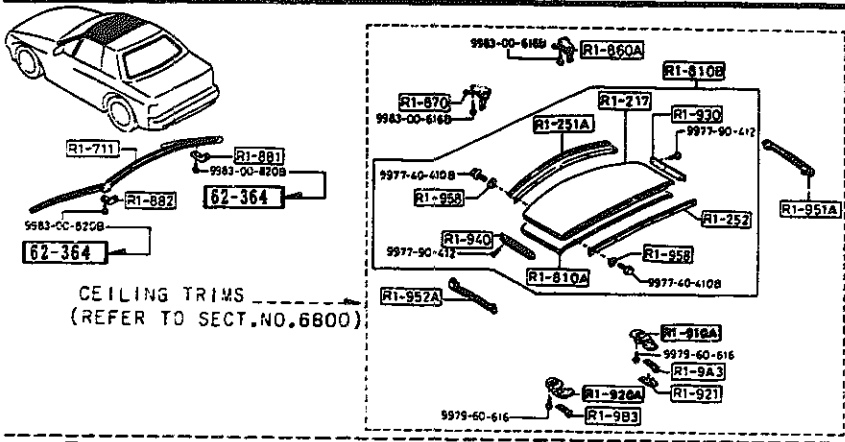

AUFA02

PART NO.	QTY	MODEL/RESTRICTION	MODEL/RESTRICTION	MODEL/RESTRICTION	FPGM-TO
R1-915		HOOK 'B', HOOD			
FB67-R1-91ZC	5				
R1-920A		LOCK(L), HINGE-TOP			
FB67-R1-920E	1				
R1-921		COVER, KNDB-HINGE			
FB67-R1-921A	1				
02		FDB FE1 BLACK			
48		FD9 BLUE			
R1-926		WASHER, HOOK-HOOD COVER			
FB67-R1-926A	13				
R1-930		RETAINER(R), ROOF PANEL			
FB67-R1-930A	1				
R1-940		RETAINER(L), ROOF PANEL			
FB67-R1-940A	1				
R1-951A		WTHSTP(R), ROOF PANEL			-9602
FB67-R1-951E	1				9602-
FC54-R1-951B	1				
R1-952A		WTHSTP(L), ROOF PANEL			-9602
FB67-R1-952E	1				9602-
FC54-R1-952B	1				
R1-953		HOOK, HOOD-REAR CORNER			
B235-R1-953	12				
R1-958		WASHER, HOOK 'A' & 'B'			
B235-R1-958A	10				
62-364		SCREW, STRIKER			
FB67-R1-222	4				9201-
67-051P		HARNES, REAR DEFFOGER			
FB67-67-060A	2				

9201 FC3MNR-701886
9602 FC3MNR-708068

CAT. AUFA02-06

1992-05

1992-05

6330A SUNROOF (CONVERTIBLE)

6330A -6 * SUNROOF (CONVERTIBLE)

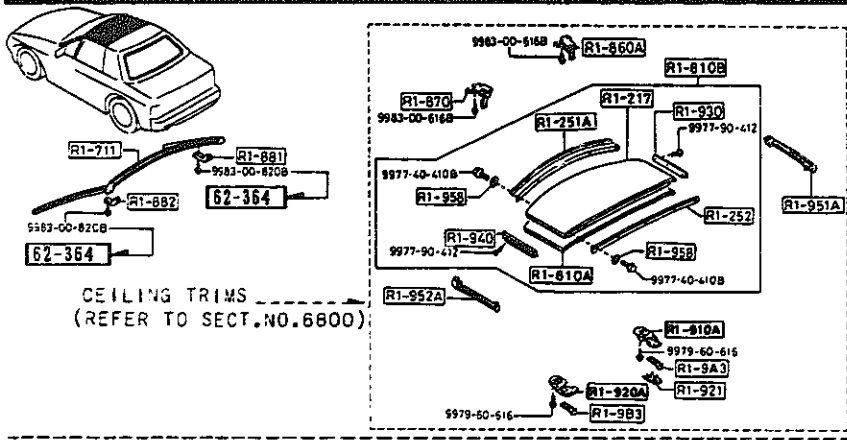

CEILING TRIMS (REFER TO SECT.NO.6800)

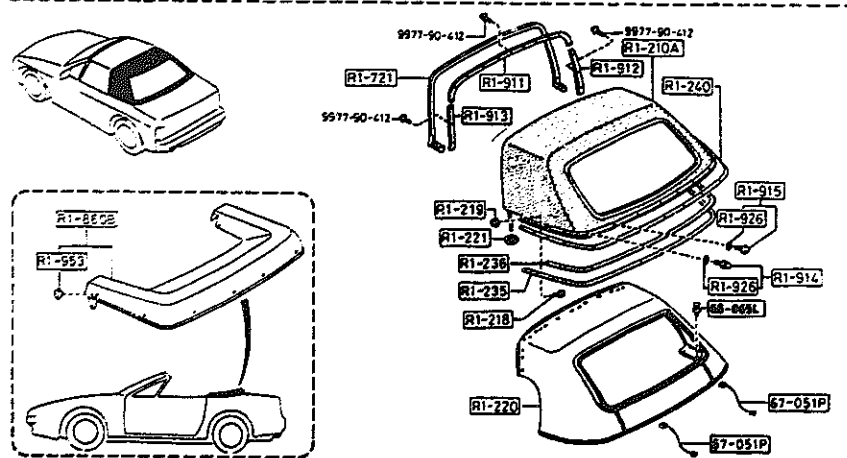
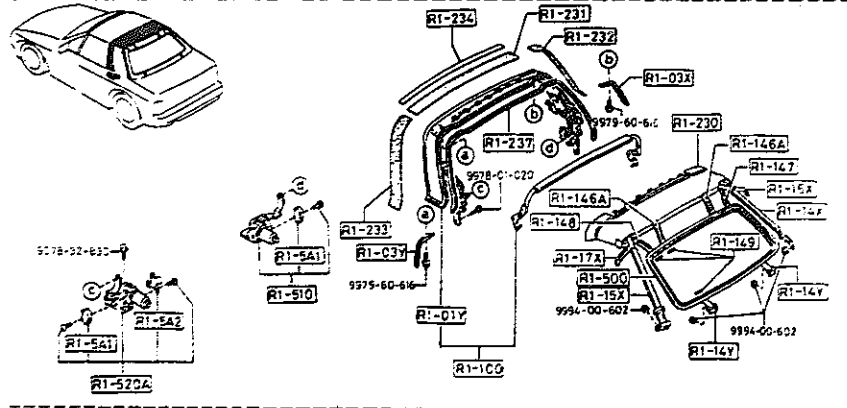

PART NO.	QTY	MODEL/RESTRICTION	MODEL/RESTRICTION	MODEL/RESTRICTION	FROM-TO
<u>68-865L</u>		FASTENER			
B042-68-865	13				
00		F08 F09 FE1 BLACK			

AUFA02

CAT. AUFA02-06

1992-05

(THIS ILLUSTRATION CONSISTS OF 2 PAGES)

(THIS ILLUSTRATION CONSISTS OF 2 PAGES)

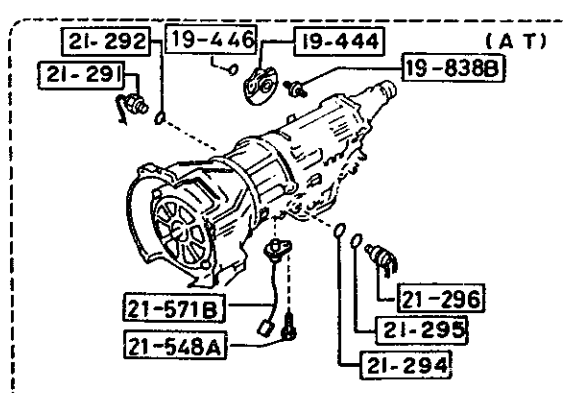
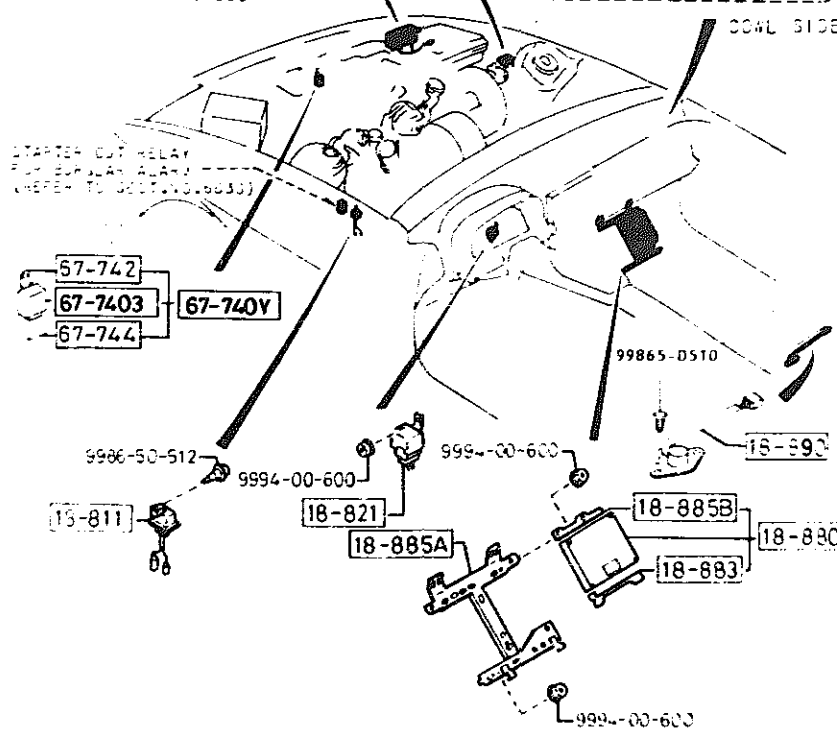
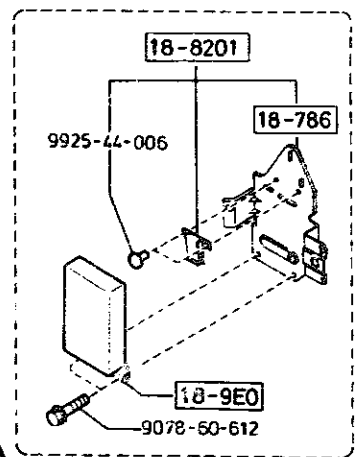
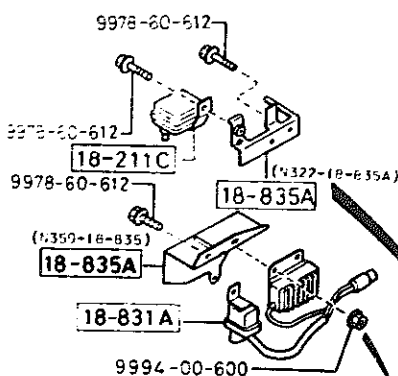
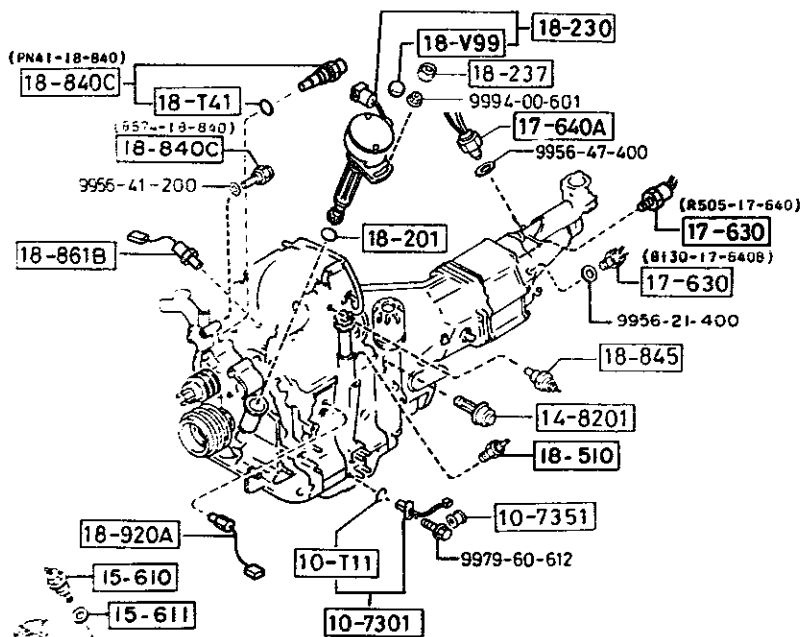

STARTER CUT RELAY
FOR SUPPLY ALARM
(REFER TO SECTION 9833)

CCWL SIDE

6600 SWITCHES & RELAYS (ENGINE)

(1/2)

(THIS ILLUSTRATION CONSISTS OF 2 PAGES)

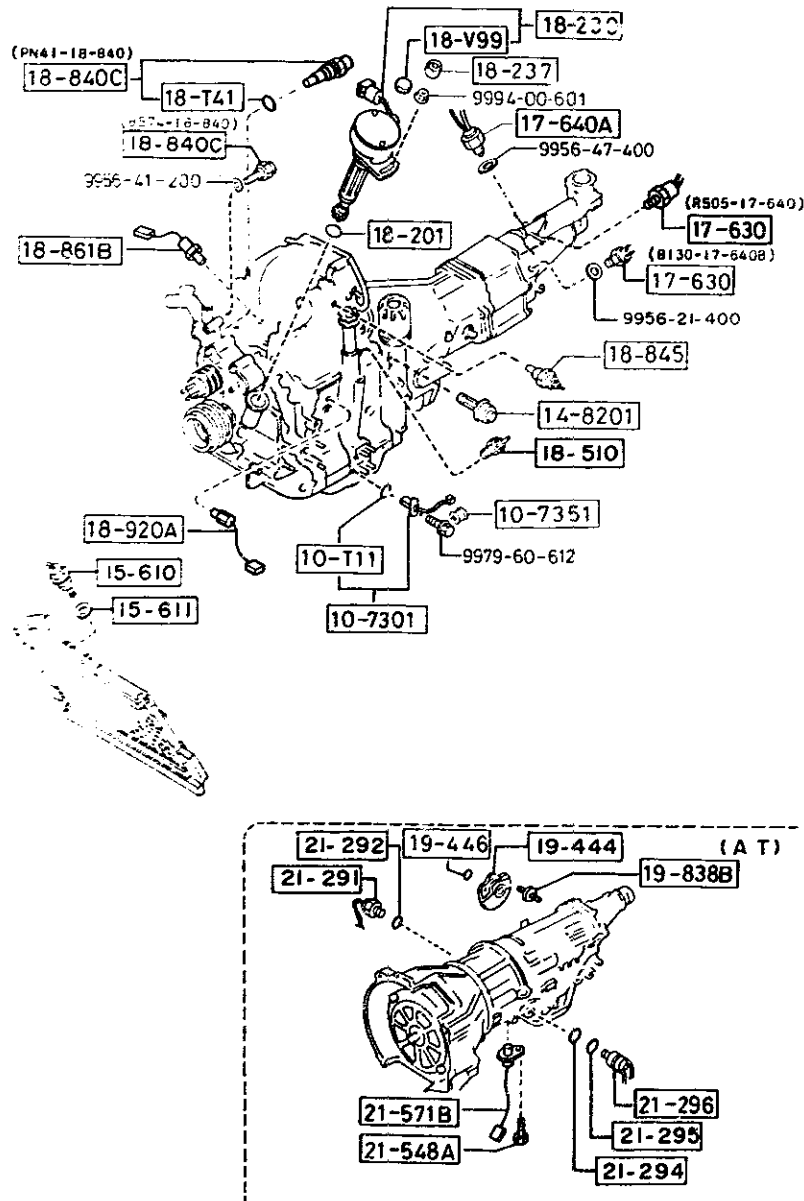

6600 -1 SWITCHES & RELAYS (ENGINE)

PART NO.	QTY	MODEL/RESTRICTION	MODEL/RESTRICTION	MODEL/RESTRICTION	FROM-TO
10-T11 N326-10-T11	1	RING, 'O'-OIL LEVEL S ENSOR			
10-7301 N326-10-470	1	SENSOR, OIL LEVEL			
10-7351 N231-10-735	1	PROTECTOR			
14-8201 N201-14-820	1	GAUGE UNIT, OIL PRES.			
15-610 N337-15-610	1	SENSOR, WATER LEVEL			
15-611 8553-15-611	1	GASKET			
17-630 R505-17-640	1	SWITCH (BACK UP LAMP SWITCH) ((TURBO) > (MT))			
8130-17-640B A (8130-17-640C)	1				-9415
8130-17-640C	1	(BACK UP LAMP SWITCH) ((W/O TURBO) > (MT))			9415-
17-640A M502-17-640B A (M502-17-640C)	1	SWITCH, PARK & NEUTRA L			-9501
M502-17-640C	1	(MT)			9501-
18-T41 F8B5-18-T41	1	RING, 'O'-WATER THERM O SW. ((W/O TURBO) > (AT)) ((TURBO) > (MT))			
18-V99 N326-18-V99	1	CAP. BLIND-CRANK ANGL E SEN			
18-201 99541-03501	1	RING, 'O'			
9415 FC3***-706193 9501 FC3***-707092					

SECTION NAME INDEX (BODY) 2/2

LO.NO	SEC.NO	SECTION NAME	LO.NO	SEC.NO	SECTION NAME	LO.NO	SEC.NO	SECTION NAME
4-C03	6100	HEATER	4-E08	6703	WIRING HARNESSSES(DOOR,FLOOR/CEILING)			
4-E03	6110	HEATER UNIT COMPONENTS	4-G08	6704	WIRING HARNESS CLAMPS			
4-F03	6115	HEATER CONTROLS COMPONENTS	4-J08	6720	WINDSHIELD WASHER (1.5L & 2.5L)			
4-G03	6120	HEATER BLOWER COMPONENTS	4-L08	6720 A	WINDSHIELD WASHER (5.7L)			
4-I03	6130	AIR CONDITIONER	4-N08	6730	WINDSHIELD WIPERS			
4-J03	6230	LIFT GATE MECHANISMS (COUPE)	4-C09	6740	WIPER MOTOR COMPONENTS(FRONT)			
4-M03	6300	WINDOW GLASSES (COUPE)	4-D09	6750	WINDOW WIPER & WASHER (REAR)			
4-N03	6300A	WINDOW GLASSES (CONVERTIBLE)	4-G09	6760	WINDOW WIPER MOTOR COMPONENTS (REAR)			
4-C04	6330	SUNROOF (COUPE)	4-H09	6800	CEILING TRIMS (COUPE)			
4-G04	6330A	SUNROOF (CONVERTIBLE)	4-J09	6800A	CEILING TRIMS (CONVERTIBLE)			
4-M04	6600	SWITCHES & RELAYS (ENGINE)	4-K09	6810	ROLLEBAR (CONVERTIBLE)			
4-G05	6610	DASHBOARD SWITCHES	4-N09	6820	PILLAR TRIMS (COUPE)			
4-H05	6611	COMBINATION SWITCH	4-F10	6820A	PILLAR TRIMS (CONVERTIBLE)			
4-I05	6612	CLUSTER SWITCH	4-G10	6840	TRIMS & SCUFF PLATES (COUPE)			
4-L05	6615	POWER WINDOW SWITCHES	4-H09A	6840A	TRIMS & SCUFF PLATES (CONVERTIBLE)			
4-M05	6630	RELAYS & UNIT (BODY)	4-N10	6845	STRAGE BOX (COUPE) (GXL,TURBO)			
4-D06	6635	DOOR SWITCH & HORNS	4-D11	6860	FLOOR MATS & PADS (COUPE)			
4-E06	6640	AUTO CRUISE CONTROL SYSTEM	4-K11	6860A	FLOOR MATS & PADS (CONVERTIBLE)			
4-F06	6680	AUDIO SYSTEMS (RADIO & TAPE DECK) (COUPE)	4-C12	6870	SERVICE TOOLS			
4-K06	6680 A	AUDIO SYSTEMS (RADIO & TAPE DECK) (CONVERTIBLE)	4-D12	6900	VISORS,ASSIST HANDLES & MIRRORS (COUPE)			
4-M06	6682	AUDIO SYSTEMS (ANTENNA & SPEAKER) (COUPE)	4-H12	6900A	VISORS,ASSIST HANDLES & MIRRORS (CONVERTIBLE)			
4-D07	6682 A	AUDIO SYSTEMS (ANTENNA & SPEAKER) (CONVERTIBLE)	4-K12	6930	CAUTION PLATES & LABELS			
4-G07	6684	AUDIO SYSTEMS(NOISE SUPPRESSOR & EARTH CORD)	4-N12	7250	QUARTER WINDOW & TRIMS			
4-H07	6700	WIRING HARNESSSES(FRONT & REAR)	4-E13	7800	SPOILERS & RELATED PARTS			
4-N07	6701	WIRING HARNESSSES(ENGINE & TRANSMISSION)	4-C14	7900	ACCESSORIES			
4-D08	6702	WIRING HARNESSSES(DASHBOARD)						

CATLOG-NO= AUFA02-06

DATE. 1992-05

(THIS ILLUSTRATION CONSISTS OF 2 PAGES)

FROM-TO

-9501

-9501

9501-

-9501

9501-

9501-

9501-

-9501

9501-0701

1992-05

AUFA02

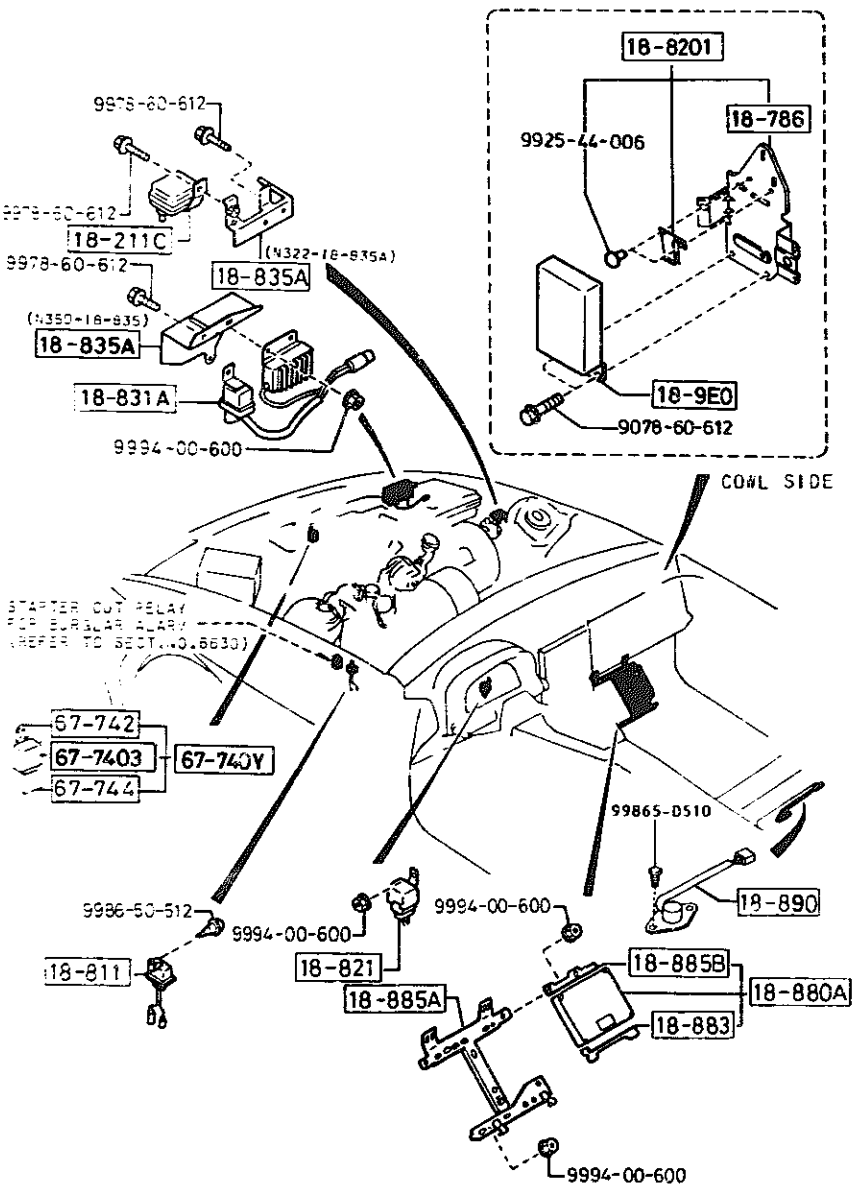

PART NO.	QTY	MODEL/RESTRICTION	MODEL/RESTRICTION	MODEL/RESTRICTION	FROM-TO
18-211C		SENSOR, M.A.P.			
N350-18-211	1	(W/O TURBO)			
N370-18-211	1	(TURBO)			
18-230		SENSOR, CRANKSHAFT POS. SI.			
N326-18-230	1				
18-237		CAP, CRANK ANGLE SENSOR			
N326-18-237	1				
18-510		UNIT, HEAT GAUGE			
JE15-18-51X	1				
18-786		BRACKET, CONTROL UNIT			
N361-18-946A	1	(MT)			
18-811		RELAY, MAIN			
N326-18-811B	1				-9101
N350-18-811	1				9101-
18-8201		BRACKET, CONTROL UNIT			
N361-18-945B	1	(AT)			
18-821		RELAY, FUEL PUMP			
N326-18-821A	1				
18-831A		RESISTOR, SOL.-FUEL PUMP			
N374-18-831	1				
18-835A		BRACKET			
N322-18-835A	1				
N350-18-835	1				
18-840C		SENSOR, TEMP.-ENG. COOLANT DENSO			
PN41-18-840	1	((W/O TURBO)) (AT) ((TURBO)) (MT)			
8574-18-840	1	DENSO			
18-845		SENSOR, IN. AIR TEMP			
9101 FC3XXX-700067					

CAT. AUFA02-06

1992-05

4-C 5

6600 SWITCHES & RELAYS (ENGINE)

(1/2)

(THIS ILLUSTRATION CONSISTS OF 2 PAGES)

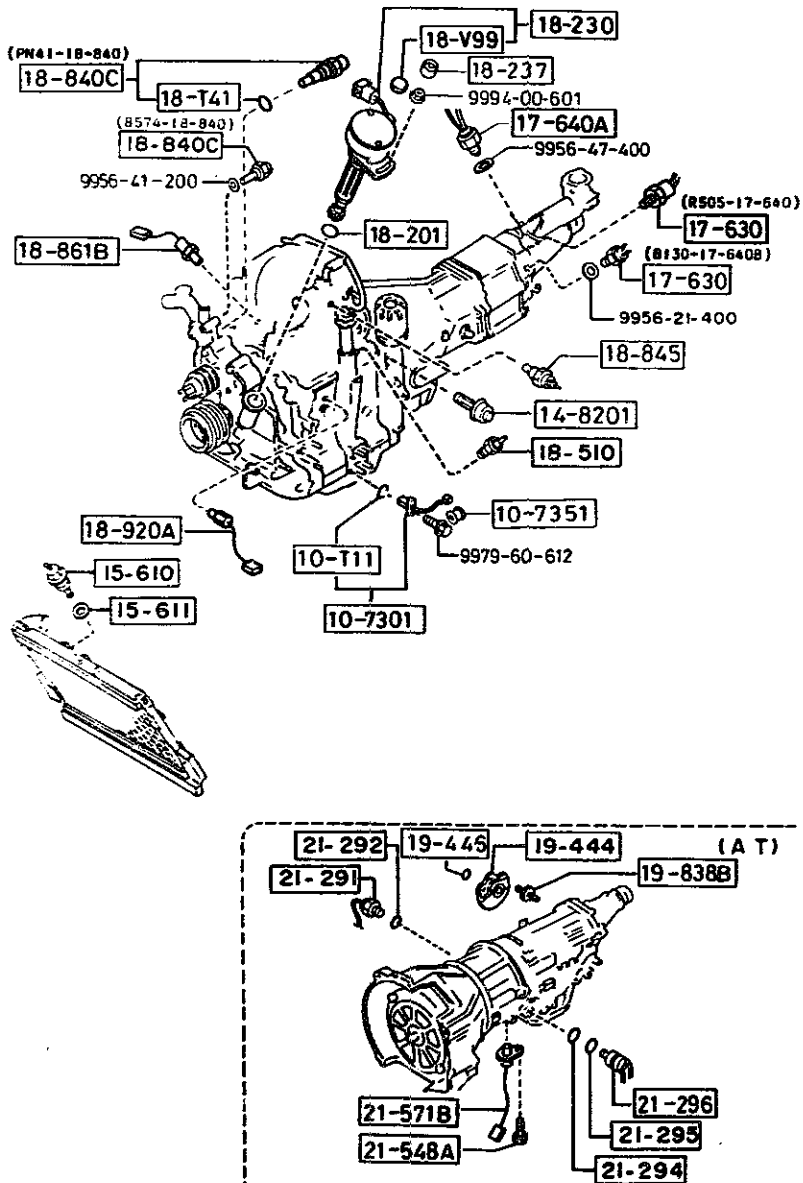

6600 -3 SWITCHES & RELAYS (ENGINE)

PART NO.	QTY	MODEL/RESTRICTION	MODEL/RESTRICTION	MODEL/RESTRICTION	FROM-TO
CONT'D					
N326-18-845	1				
18-861B		SENSOR, OXYGEN			
N350-18-861	1				
18-880A		MODULE, POWER & RAIN CONTROL			
N350-18-880	1	(W/EM LABEL-CALIF.) (W/O TURBO)>(CPE)			
N351-18-880	1	(W/EM LABEL-FED.) (W/O TURBO)>(CPE)			
N352-18-880	1	(W/EM LABEL-CALIF.) (CONVERTIBLE)			
N353-18-880	1	(W/EM LABEL-FED.) (CONVERTIBLE)			
N370-18-880	1	((TURBO)>(CPE)			
18-883		BRACKET, CONTROL UNIT			
N326-18-883	1				
18-885A		BRACKET, CONTROL UNIT			
N326-18-885A	1	(W/O AIR BAG)			
N387-18-885A	1	(W/AIR BAG)			
18-885B		BRACKET, CONTROL UNIT			
HE21-18-885A	1				
18-890		SWITCH, THERMO			
N326-18-890A	1				
18-9E0		MODULE, PWT. CONTROL			
N351-18-9E1B A (N351-18-9E1C)	1				-0201
N351-18-9E1C	1	(AT)			0201-
18-920A		SENSOR, KNOCK			
N318-18-921	1	(TURFO)			
19-444		SWITCH, INHIBITOR			
BV09-19-444	1	(AT)			
19-446		RING, 'O'			
0338-19-446	1	(AT)			

0201 FCSXXX-806074

CAT. AUFA02-06

1992-05

(THIS ILLUSTRATION CONSISTS OF 2 PAGES)

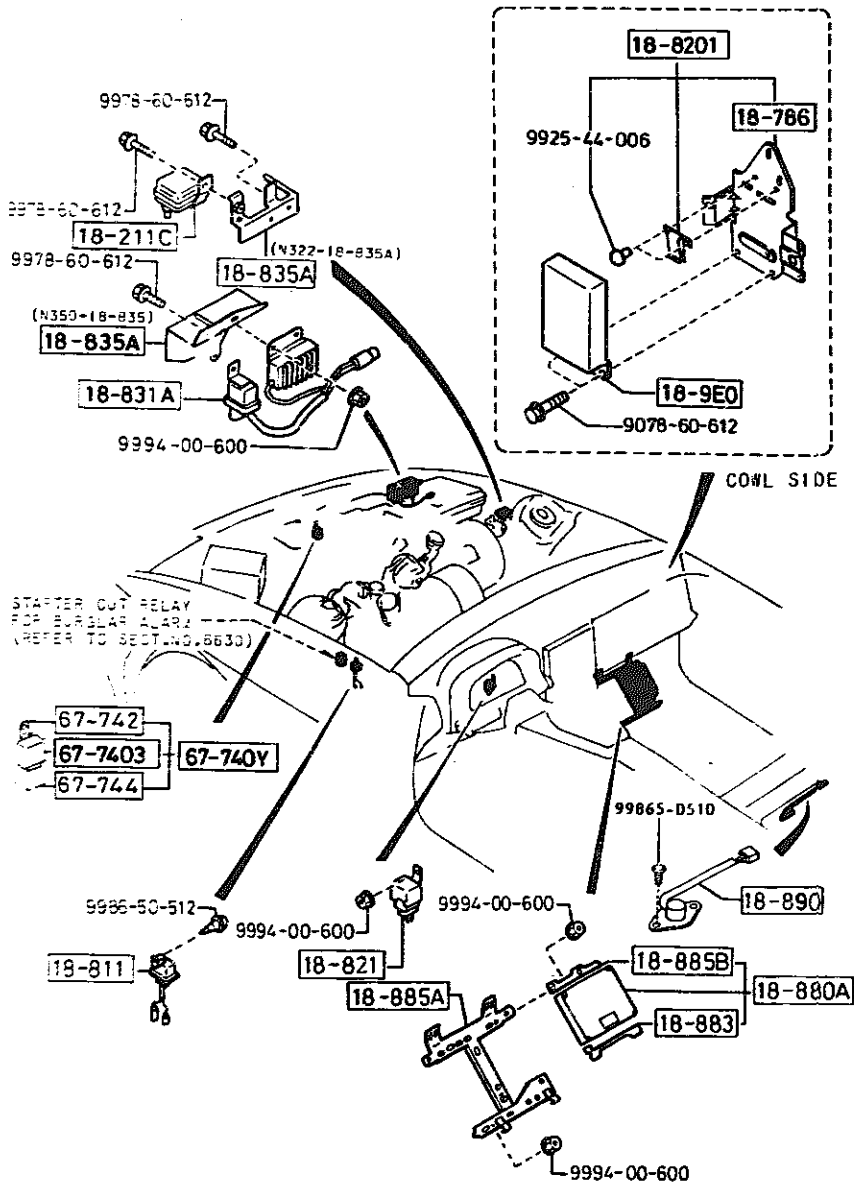

PART NO.	QTY	MODEL/RESTRICTION	MODEL/RESTRICTION	MODEL/RESTRICTION	FROM-TO
19-838B		BOLT			
BU17-19-838	2	(AT)			
21-291		SWITCH,OIL PRESSURE			
BV09-21-241	1	(AT)			
21-292		RING,'O'			
*BU01-21-292A	1	(AT)			
21-294		RING,'O'			
BU01-21-294	1	(AT)			
21-295		RING,'O'			
BU01-21-295	1	(AT)			
21-296		SOLENOID, LOCK UP CONTROL			
BV09-21-3A5	1	(AT)			
21-548A		BOLT			
BV01-21-548	1	(AT)			
21-571B		GENERATOR,SPEED PULSE			
BV09-21-5H1	1	(AT)			
67-740Y		RELAY & COVER,NORMAL OPEN 30A			
H320-67-740	1	(FOR COOLING FAN RELAY) ((W/O AIR BAG) ((W/AIR BAG)>(MT))			
H430-67-740	1	((W/AIR BAG)>(AT))			
67-7403		RELAY,N.O.			
H270-67-740	1	30A (FOR COOLING FAN RELAY) ((W/O TURBO)>(AT)) ((TURBO)>(MT))			
67-742		BRACKET,RELAY			
H320-67-742	1	(FOR COOLING FAN RELAY) ((W/O TURBO)>(AT)) ((TURBO)>(MT))			

6600 SWITCHES & RELAYS (ENGINE)

(1/2)

(THIS ILLUSTRATION CONSISTS OF 2 PAGES)

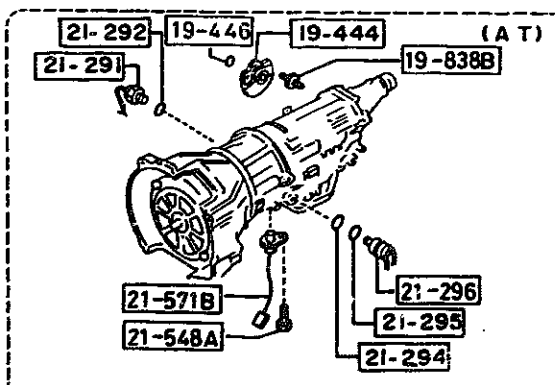
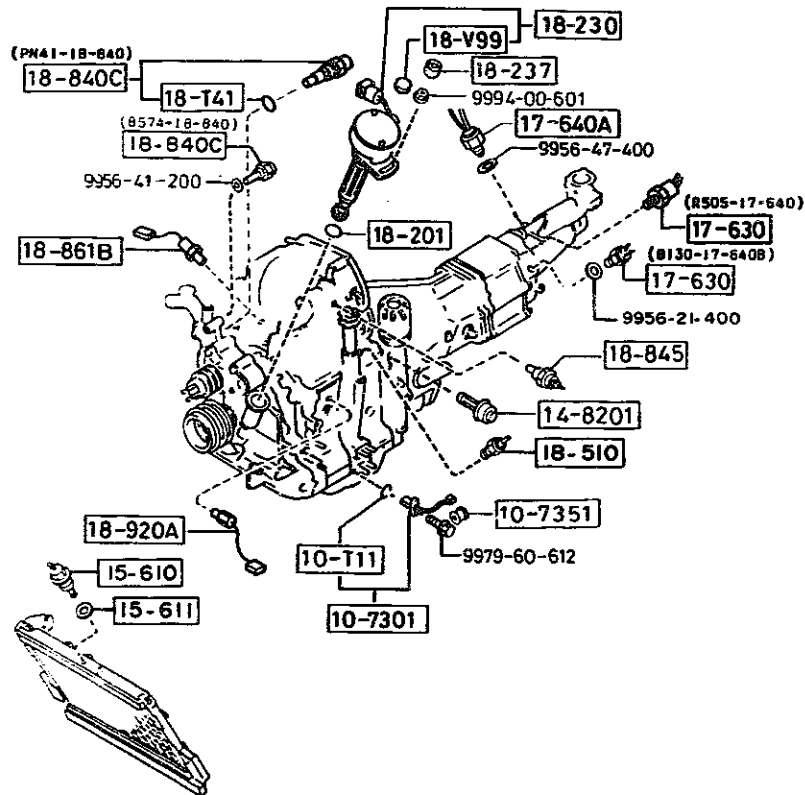

6600 -5 * SWITCHES & RELAYS (ENGINE)

PART NO.	QTY	MODEL/RESTRICTION	MODEL/RESTRICTION	MODEL/RESTRICTION	FROM-TO
67-744 H311-67-744	1	BODY, RELAY-WATER PRO OF (FOR COOLING FAN REL AY) (W/O TURBO)>(AT)) (TURBO)>(MT))			

6610 DASHBOARD SWITCHES

6610 -1 * DASHBOARD SWITCHES

FROM-TO

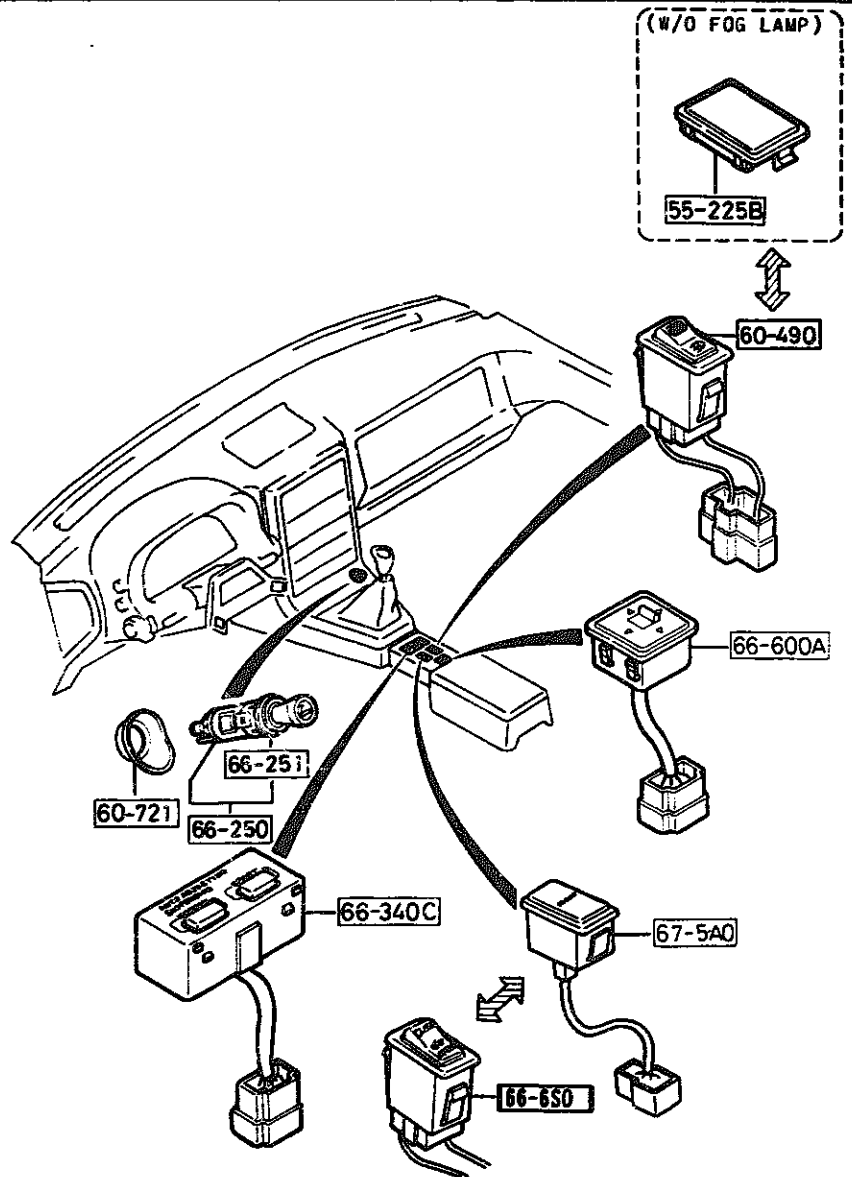

PART NO.	QTY	MODEL/RESTRICTION	MODEL/RESTRICTION	MODEL/RESTRICTION	FROM-TO
55-225B		COVER, HOLE			
B001-55-225A	1	GTU, GTUS, (W/O FOG LAMP)			
60-490		SWITCH, FOG LAMP			
F044-66-480	1	GXL, TURBO, CONV, (W/FOG LAMP)			
60-721		PROTECTOR			
FB01-66-241	1				
66-250		LIGHTER, CIGAR			
FB01-66-250	1				
66-251		RING, ILLUMINATION			
UB40-66-251	1				
66-340C		SWITCH, ADJUSTBL DAMP ER			
FB07-66-340	1	(A.A. SUSP)			
66-6S0		SWITCH, SOFT TOP			
FC66-66-6S0	1	(W/AIR BAG)			
66-600A		SWITCH, RMT. MIRROR			
FB02-66-600A	1	USA, (DR MIRROR ELECT.)			
67-5A0		DISPLAY, SECURITY-ALA RM			
FB01-67-5A0A	1	(W/O AIR BAG)			

1992-05

AUFA02

CAT. AUFA02-06

1992-05

6611 -1 * COMBINATION SWITCH

6611 COMBINATION SWITCH

(W/AIR BAG)

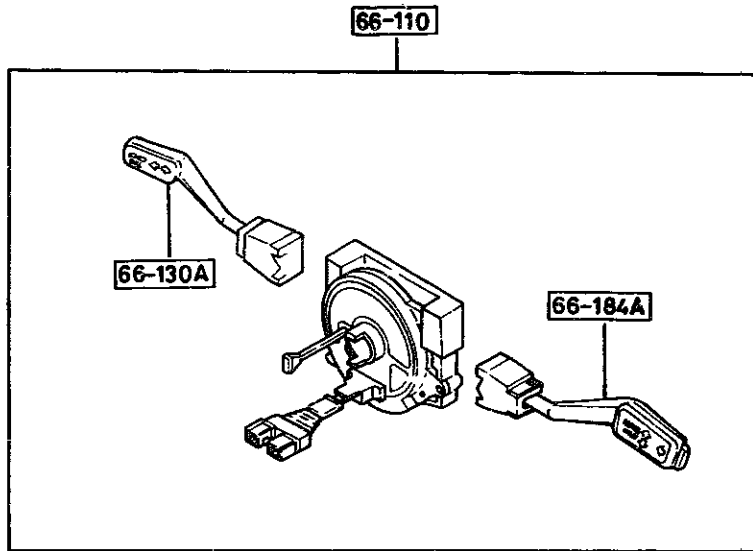

(W/O AIR BAG)

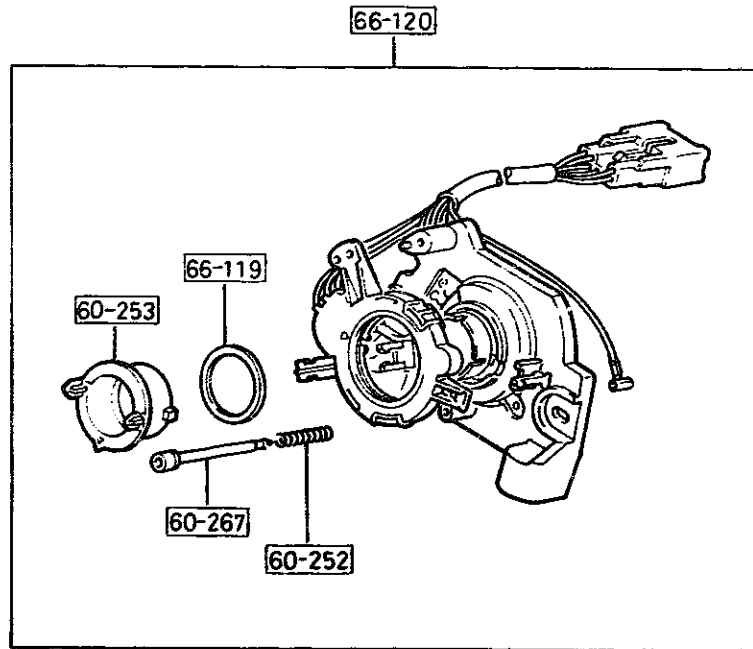

PART NO.	QTY	MODEL/RESTRICTION	MODEL/RESTRICTION	MODEL/RESTRICTION	FROM-TO
60-252		SPRING			
FB01-66-117	1	(W/O AIR BAG)			
60-253		CAM,CANCEL			
FB01-66-126	1	(W/O AIR BAG)			
60-267		CONTACT,HORN			
FB01-66-127	1	(W/O AIR BAG)			
66-110		SWITCH,COMBINATION			
FC66-66-120A	1	(W/AIR BAG)			
66-119		WASHER,CONTACT SPRING			
FB01-66-119	1	(W/O AIR BAG)			
66-120		SENSOR,TURN CANCEL			
FB01-66-120	1	(W/O AIR BAG)			
66-130A		SWITCH,TURN-CLUSTER SW			
FC66-66-130	1	(W/AIR BAG)			
66-184A		SWITCH,CRUISE-CRUISE R			
FC66-66-34X	1	(W/AIR BAG)			

6612 CLUSTER SWITCH

6612 -1 CLUSTER SWITCH

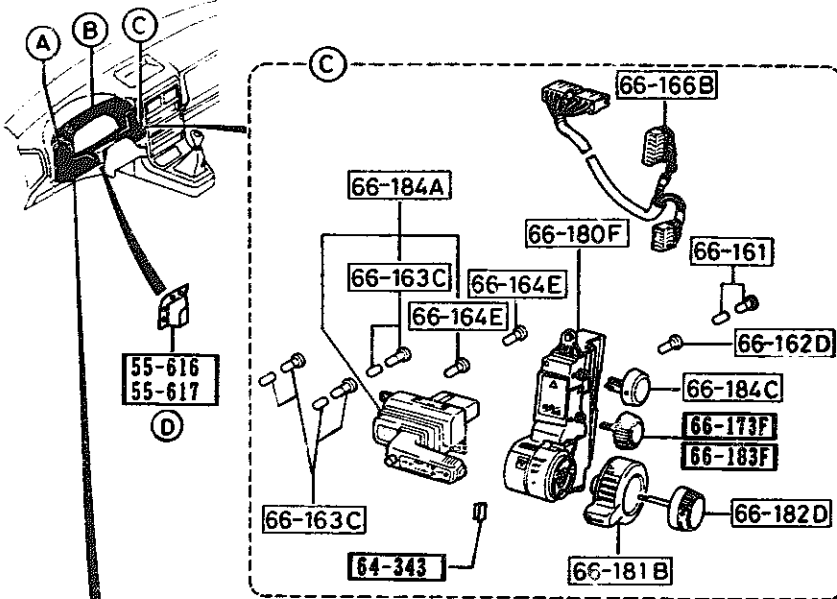

NOTE
 (A) ... (D) ⇒ 66-160B
 THE D-CODE OF 66-160B CONSISTS OF
 FIGURE NUMBERS (A) THROUGH (D).

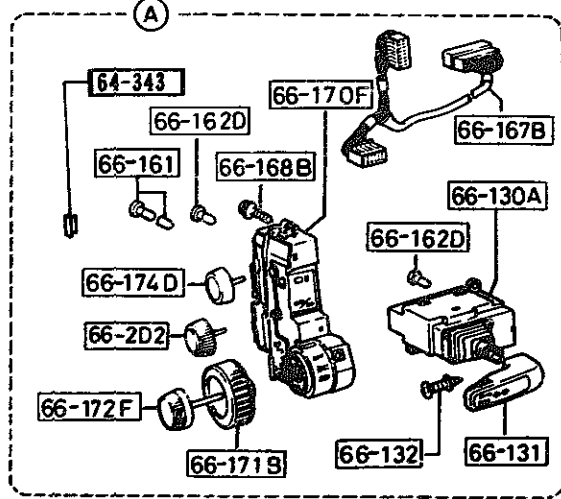
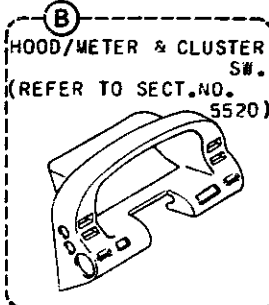

PART NO.	QTY	MODEL/RESTRICTION	MODEL/RESTRICTION	MODEL/RESTRICTION	FROM-TO
55-616		COVER(R), CLUSTER SWITCH			
FC66-55-616	1	(W/AIR BAG)			
55-617		COVER(L), CLUSTER SWITCH			
FC67-55-617	1	(W/AIR BAG)			
64-343		SPRING			
FC66-64-343	2	(W/AIR BAG)			
66-130A		SWITCH, TURN-CLUSTER SW.			
FC01-66-130	1	(W/O AIR BAG)			
66-131		KNOB, TURN-CLUSTER SWITCH			
FC01-66-131	1	(W/O AIR BAG)			
66-132		SCREW & WASHER, TURN KNOB			
FC01-66-132	1	(W/O AIR BAG)			
66-160B		SWITCH, CRUSTER			
FC01-66-160A	1	GTU, GTUS, (W/O AUTO CRUISE) ((CPE))(W/O A.LOCK BRAKE)			
FC02-66-160A	1	NON USA,			
FC07-66-160A	1	GXL, TURBO, (W/AUTO CRUISE) (CPE)			
FC08-66-160A	1	NON USA,			
FC17-66-160A	1	GTU, GTUS, (W/O AUTO CRUISE) ((CPE))(A.LOCK BRAKE)			
FC18-66-160A	1	NON USA,			
FC33-66-160A	1	(W/O H.I. CLEANER) ((CONVERTIBLE))(W/O AIR BAG)			
FC34-66-160A	1	NON USA,			
FC66-66-160A	1	((CONVERTIBLE))(W/AIR BAG)			
66-161		BULB 'A', CLUSTER SWITCH			
FB01-66-161	2				

CAT. AUFA02-06

1992-05

FROM-TO

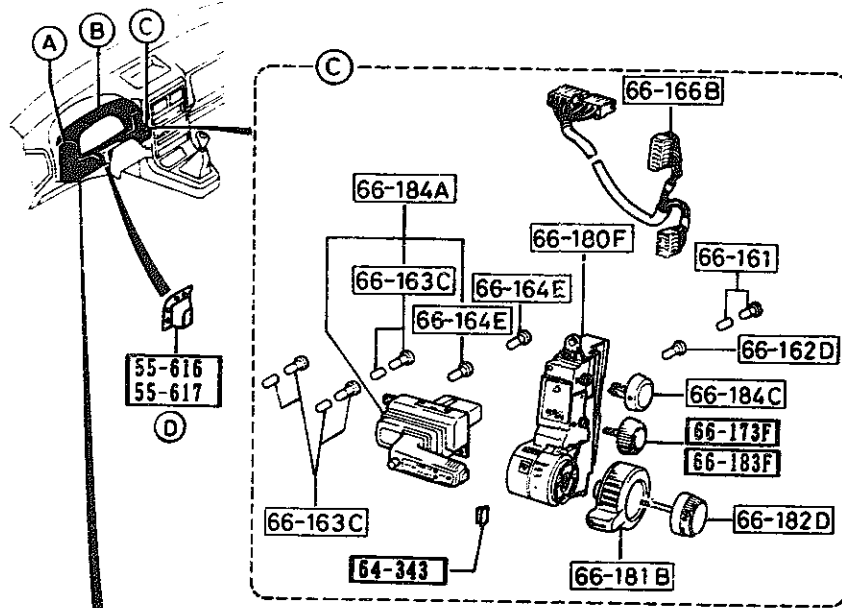

NOTE
 A ... D ⇒ 66-160B
 THE D-CODE OF 66-160B CONSISTS OF
 FIGURE NUMBERS A THROUGH D.

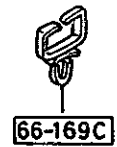
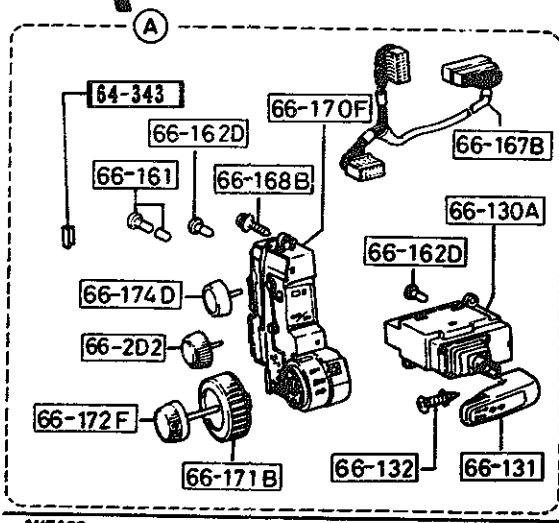
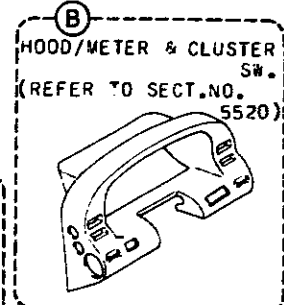

PART NO.	QTY	MODEL/RESTRICTION	MODEL/RESTRICTION	MODEL/RESTRICTION	FROM-TO
66-162D		BULB 'B', CLUSTER SWIT			
FB01-66-162	2	CH (W/AIR BAG)			
	3	(W/O AIR BAG)			
66-163C		BULB 'C', CLUSTER SWIT			
FC01-66-163	3	CH GXL, TURBO, (W/AUTO CRUISE CONT)			
		(W/O AIR BAG)			
66-164E		BULB 'D', CLUSTER SWIT			
FB01-66-164	2	CH GXL, TURBO, (W/AUTO CRUISE CONT)			
		(W/O AIR BAG)			
66-166B		HARNES, WIPER-CLUSTE			
FC01-66-166	1	R SW. (W/O AIR BAG)			
FC66-66-166	1	(W/AIR BAG)			
66-167B		HARNES, LIGHT-CLUSTE			
FC01-66-167	1	R SW. (W/O AIR BAG)			
FC66-66-167A	1	(W/AIR BAG)			
66-168B		SCREW, CLUSTER SWIT			
FC01-66-168	1	(W/O AIR BAG)			
	6	(W/AIR BAG)			
66-169C		CLIP, CORD-CRUSTER SW			
FB01-66-169	1	ITCH (W/O AIR BAG)			
66-170F		SWITCH, LIGHT-CLUSTER			
FC01-66-170	1	SW. USA, (W/O H.L. CLEANER)			
FC02-66-170	1	NON USA,			
66-171B		KNOB, LIGHT-CLUSTER S			
FC01-66-171	1	WITCH			
66-172F		KNOB, PANEL LIGHT-CLU			
FC01-66-172	1	STER			

6612 CLUSTER SWITCH

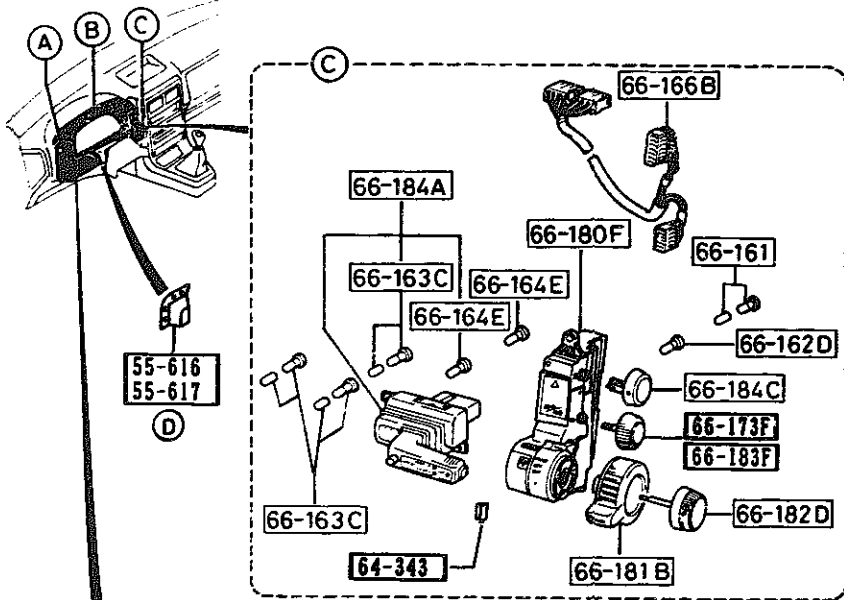

NOTE
 (A) ... (D) ⇒ 66-160B
 THE D-CODE OF 66-160B CONSISTS OF FIGURE NUMBERS (A) THROUGH (D).

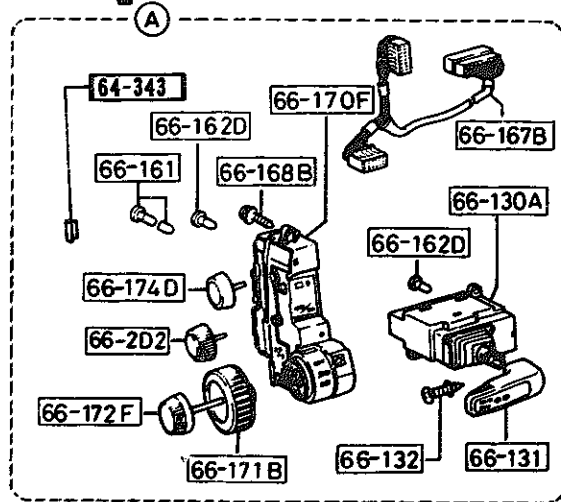

PART NO.	QTY	MODEL/RESTRICTION	MODEL/RESTRICTION	MODEL/RESTRICTION	FROM-TO
66-173F		KNOB, SMALL--CRUSTER SW.			
FC01-66-173	1				
66-174D		KNOB, REAR DEFFOG-CLUSTER			
FB01-66-174	1				
66-180F		SWITCH, WIPER--CLUSTER SW			
FC01-66-180	1	((CPE))>(W/D A.A.SUSP)			
FC07-66-180	1	((CPE))>(A.A.SUSP)			
FC33-66-180	1	((CONVERTIBLE))>(W/D AIR BAG)			
FC66-66-180	1	((CONVERTIBLE))>(W/AIR BAG)			
66-181B		KNOB, WIPER--CLUSTER SWITCH			
FC01-66-181	1				
66-182D		KNOB, WASHER--CLUSTER SW.			
FC01-66-182	1				
66-183F		KNOB, DUMMY--CRUSTER SWITCH			
FC01-66-183	1	GTU, GTUS, (W/D AUTO CRUISE CONT.) (CPE)			
66-184A		SWITCH, CRUISE--CRUSTER			
FC01-66-34X	1	GXL, TURBD. (W/AUTO CRUISE CONT) (W/D AIR BAG)			
66-184C		KNOB, HAZARD--CLASTER SW.			
FB01-66-184	1				
66-2D2		KNOB, SWITCH--RR WIPER			
FC02-66-173	1				

FROM-TO

-9602

9602-

-9602

9602-

9201-

1992-05

AUFA02

CAT. AUFA02-06

1992-05

6615 POWER WINDOW SWITCHES

6615 -1 * POWER WINDOW SWITCHES

FROM-TO

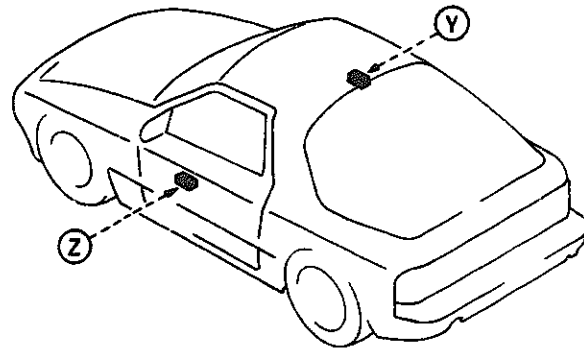

PART NO.	QTY	MODEL/RESTRICTION	MODEL/RESTRICTION	MODEL/RESTRICTION	FROM-TO
66-350 FC01-66-350B	1	SWITCH, POWER WINDOW			
66-370 FC01-66-370B	1	SWITCH, POWER WINDOW			

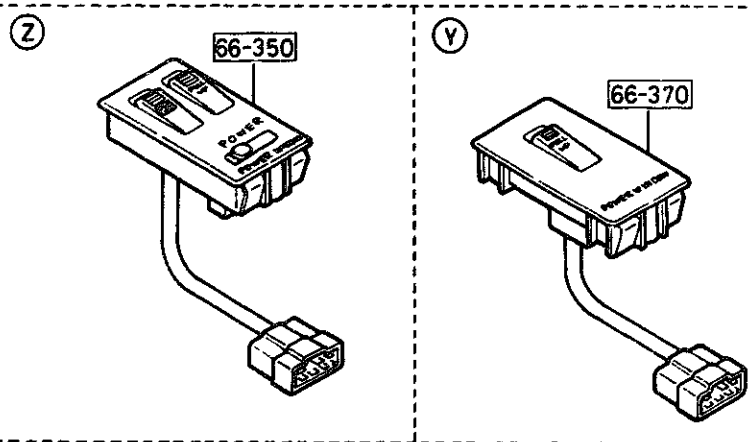

1992-05

AUFA02

CAT. AUFA02-06

1992-05

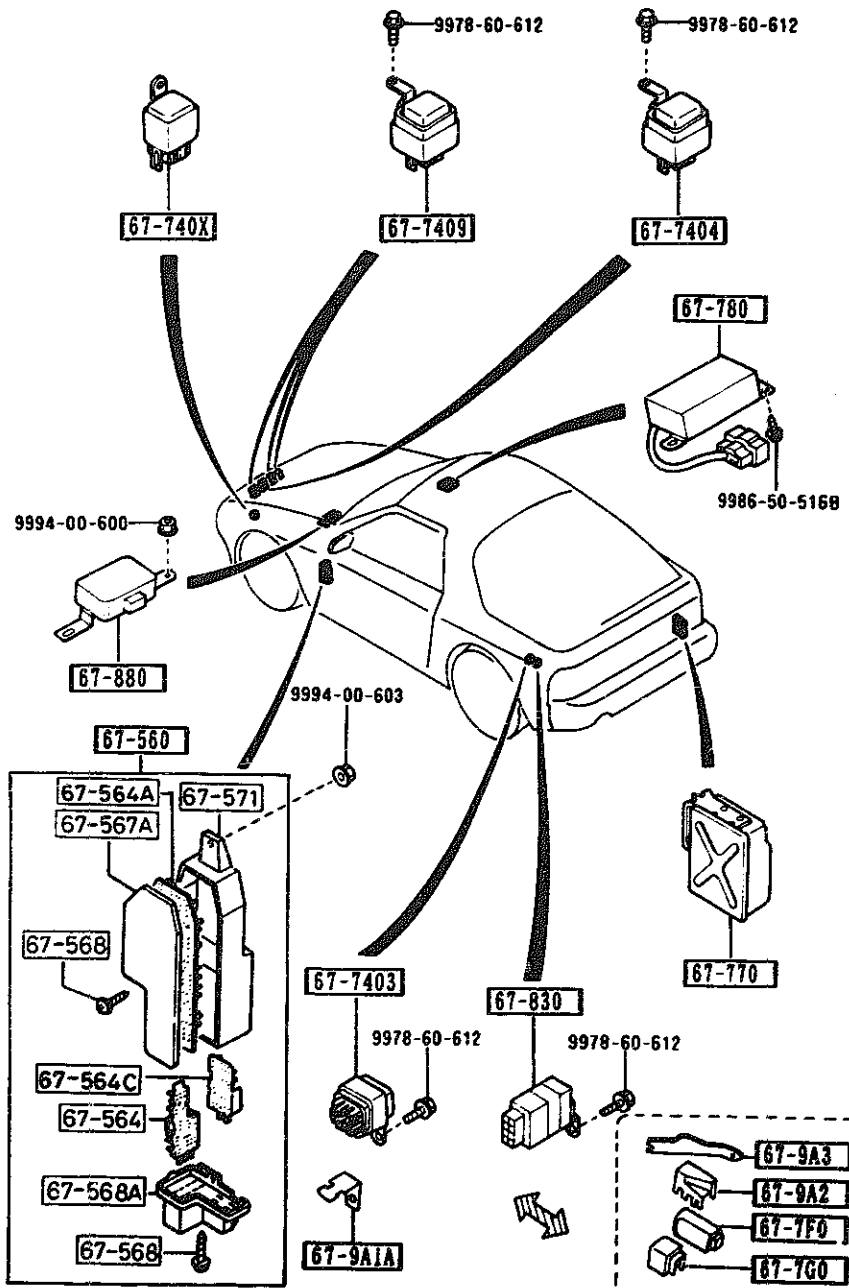

AUFA02

CAT. AUFA02-06

1992-05

4-M 5

PART NO.	QTY	MODEL/RESTRICTION	MODEL/RESTRICTION	MODEL/RESTRICTION	FROM-TO
67-560	1	UNIT,CENTRAL CONTROL			
FC01-67-560	1	(W/O AIR BAG)			
FC66-67-560A	1	(W/AIR BAG)			
67-564	1	PLATE,FLASHER-C. P. UNIT			
F801-67-564	1				
67-564A	1	BOARD,PRINT-BURGLAR ALARM			
FC01-67-564	1	(W/O AIR BAG)			
FC66-67-564	1	(W/AIR BAG)			
67-564C	1	BOARD,PRINT-DAY LIGHT UNIT			
FC15-67-564	1	NON USA.			
67-567A	1	COVER,MAIN-C. P. UNIT			
FC01-67-567	1				
67-568	2	SCREW,TAPPING			
F801-67-569	2				
67-568A	1	COVER,SUB-C. P. UNIT			
FC01-67-568	1				
67-571	1	CASE,CONTROL UNIT			
FC01-67-566	1				
67-7F0	1	UNIT,DIAGNOSIS-AIR BAG			-9A01
NA01-67-7F0	1	(W/AIR BAG)			9A01-
NA01-67-7F0A	1	(W/AIR BAG)			
67-7G0	1	UNIT,BACK UP POWER-A .BAG			-0302
NA01-67-7G0	1				0302-
AN(NA01-67-7G0A)	1				
NA01-67-7G0A	1	(W/AIR BAG)			
67-740X	1	RELAY & COVER,NORMAL CLOSE			
B311-67-740	1				
67-7403	1	RELAY,N.O.			
HR80-67-740	1	(REAR DEFOGGER RELAY)			
9A01 FC3MMW-803554 0302 FC3MMW-806493					

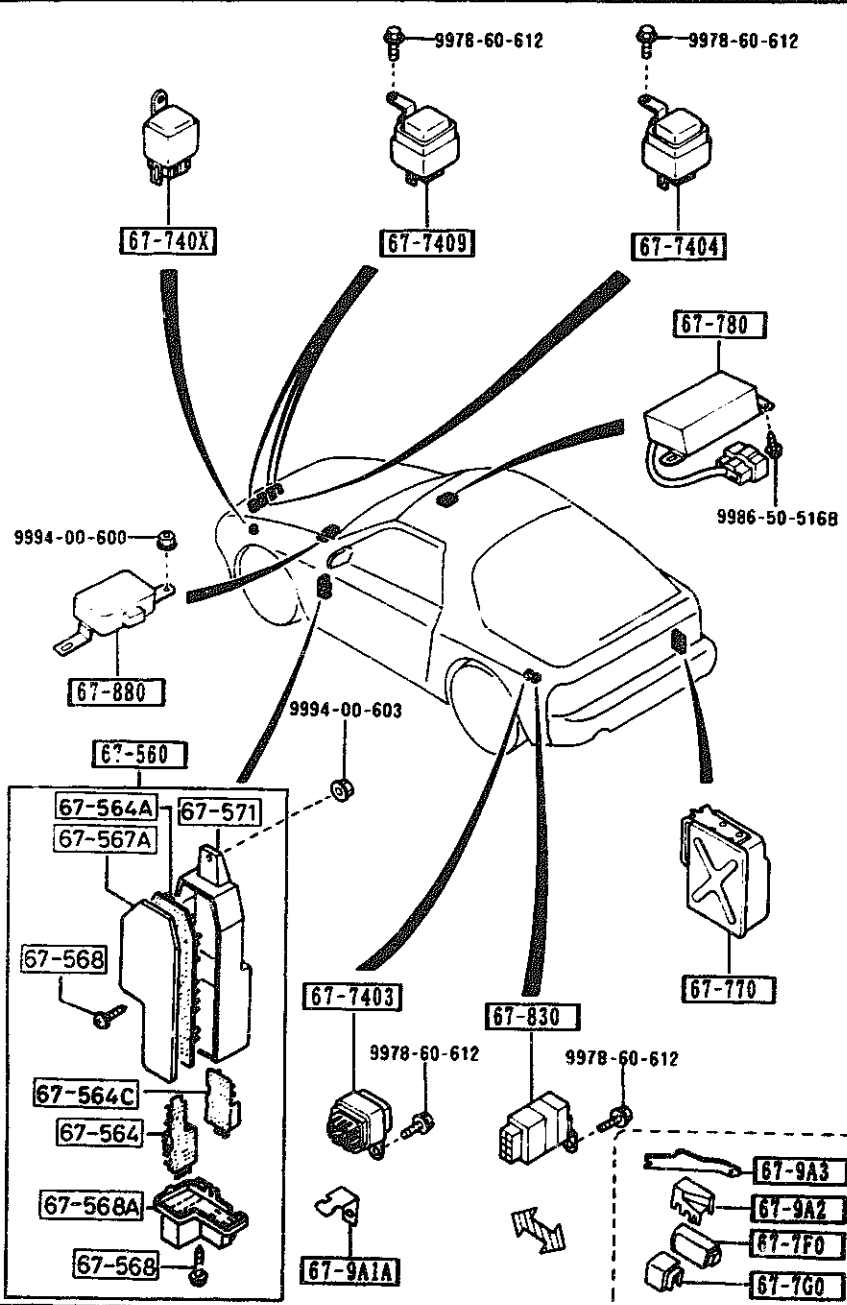

PART NO.	QTY	MODEL/RESTRICTION	MODEL/RESTRICTION	MODEL/RESTRICTION	FROM-TO
CONT'D		((CPE)>(W/O A.A.SUSP)>>(W/O A.LOCK BRAKE))			
HR80-67-740	1	(REAR DEFOGGER RELAY)			-9501
H440-67-740	1	(REAR DEFOGGER RELAY)			9501-
67-7404		RELAY, TRANSFER			
H432-67-740	1				
67-7409		RELAY 'A', NORMAL OPEN -30A			
H430-67-740	1	GTU, GTUS, (W/O POWER WIND.)			
67-770		CONT. BOX, ADJ. DUMPER			
FC04-67-770A	1	(A.A.SUSP)			
67-780		BOX, CON-AUTO SHOLDER BELTS			
FC01-67-780A	1	(CPE)			
67-830		UNIT, DOOR LOCK & TIMER			
FB01-67-830	1	((CPE)>(W/O A.A.SUSP)>>(A.LOCK BRAKE))			-9501
FC33-67-830	1	((CPE)>(A.A.SUSP)>>(W/O A.LOCK BRAKE))			9501-
67-880		BOX, CONTROL-E.C.P.S. SYS.			
FC01-67-880A	1	'89-GXL, GTUS, TURBO (W/P.S.-VELOCITY SENSOR)			

9501 FCSMNM-707092

SECTION NAME INDEX (BODY) 2/2

LD.NO	SEC.NO	SECTION NAME	LD.NO	SEC.NO	SECTION NAME	LD.NO	SEC.NO	SECTION NAME
4-C03	6100	HEATER	4-E08	6703	WIRING HARNESSSES(DOOR,FLOOR/CEILING)			
4-E03	6110	HEATER UNIT COMPONENTS	4-G08	6704	WIRING HARNESS CLAMPS			
4-F03	6115	HEATER CONTROLS COMPONENTS	4-J08	6720	WINDSHIELD WASHER (1.5L & 2.5L)			
4-G03	6120	HEATER BLOWER COMPONENTS	4-L08	6720 A	WINDSHIELD WASHER (5.7L)			
4-I03	6130	AIR CONDITIONER	4-N08	6730	WINDSHIELD WIPERS			
4-J03	6230	LIFT GATE MECHANISMS (COUPE)	4-C09	6740	WIPER MOTOR COMPONENTS(FRONT)			
4-M03	6300	WINDOW GLASSES (COUPE)	4-D09	6750	WINDOW WIPER & WASHER (REAR)			
4-N03	6300A	WINDOW GLASSES (CONVERTIBLE)	4-G09	6760	WINDOW WIPER MOTOR COMPONENTS (REAR)			
4-C04	6330	SUNROOF (COUPE)	4-H09	6800	CEILING TRIMS (COUPE)			
4-G04	6330A	SUNROOF (CONVERTIBLE)	4-J09	6800A	CEILING TRIMS (CONVERTIBLE)			
4-M04	6600	SWITCHES & RELAYS (ENGINE)	4-K09	6810	ROLLEBAR (CONVERTIBLE)			
4-G05	6610	DASHBOARD SWITCHES	4-N09	6820	PILLAR TRIMS (COUPE)			
4-H05	6611	COMBINATION SWITCH	4-F10	6820A	PILLAR TRIMS (CONVERTIBLE)			
4-I05	6612	CLUSTER SWITCH	4-G10	6840	TRIMS & SCUFF PLATES (COUPE)			
4-L05	6615	POWER WINDOW SWITCHES	4-L10	6840A	TRIMS & SCUFF PLATES (CONVERTIBLE)			
4-M05	6630	RELAYS & UNIT (BODY)	4-N10	6845	STRAGE BOX (COUPE)			
4-D06	6635	DOOR SWITCH & HORNS			(GXL,TURBO)			
4-E06	6640	AUTO CRUISE CONTROL SYSTEM	4-D11	6860	FLOOR MATS & PADS (COUPE)			
4-F06	6680	AUDIO SYSTEMS (RADIO & TAPE DECK) (COUPE)	4-K11	6860A	FLOOR MATS & PADS (CONVERTIBLE)			
4-K06	6680 A	AUDIO SYSTEMS (RADIO & TAPE DECK) (CONVERTIBLE)	4-D12	6900	SERVICE TOOLS			
4-M06	6682	AUDIO SYSTEMS (ANTENNA & SPEAKER) (COUPE)	4-H12	6900A	VISORS,ASSIST HANDLES & MIRRORS (CONVERTIBLE)			
4-D07	6682 A	AUDIO SYSTEMS (ANTENNA & SPEAKER) (CONVERTIBLE)	4-K12	6930	CAUTION PLATES & LABELS			
4-G07	6684	AUDIO SYSTEMS(NOISE SUPPRESSOR & EARTH CORD)	4-N12	7250	QUARTER WINDOW & TRIMS			
4-H07	6700	WIRING HARNESSSES(FRONT & REAR)	4-E13	7800	SPOILERS & RELATED PARTS			
4-N07	6701	WIRING HARNESSSES(ENGINE & T/MISSION)	4-C14	7900	ACCESSORIES			
4-D08	6702	WIRING HARNESSSES(DASHBOARD)						

CATLOG-NO= AUFA02-06

DATE. 1992-05

4-B 6

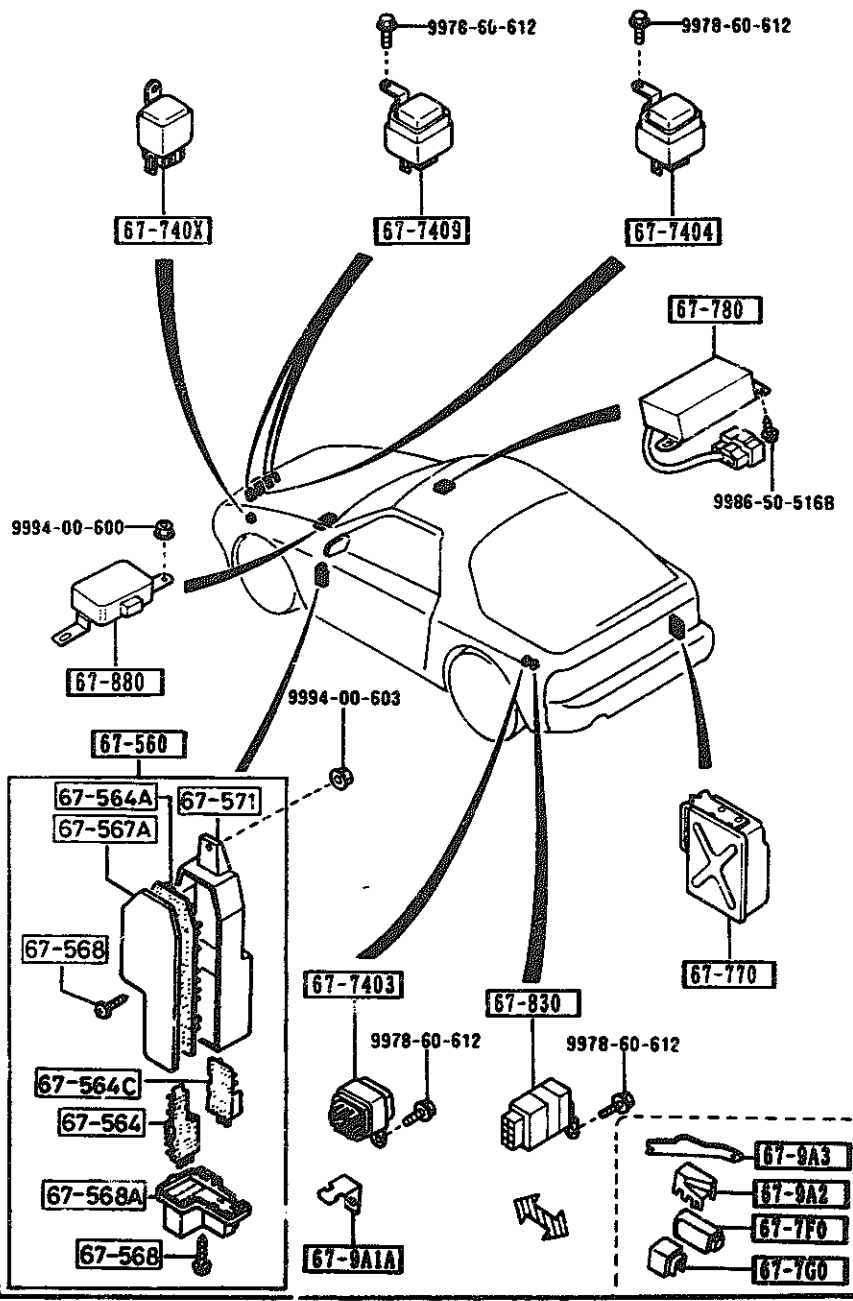

PART NO.	QTY	MODEL/RESTRICTION	MODEL/RESTRICTION	MODEL/RESTRICTION	FROM-TO
67-9A1A		BRACKET, RELAY			
FC35-67-9A1	1	((CPE))>(A.A.SUSP)>(W/O A.LOCK BRAKE)>(CONVERTIBLE)>((CPE))>(W/O A.A.SUSP)>(A.LOCK BRAKE)			9501-
67-9A2		COVER, RELAY			
FC66-67-9A2	1	(W/AIR BAG)			
67-9A3		LABEL, CAUTION-RELAY			
FC66-67-9A3	1	(W/AIR BAG)			
9501 FC3NNH-707092					

4-C 6

6635 DOOR SWITCH & HORNS

6635 -1 * DOOR SWITCH & HORNS

FROM-TO

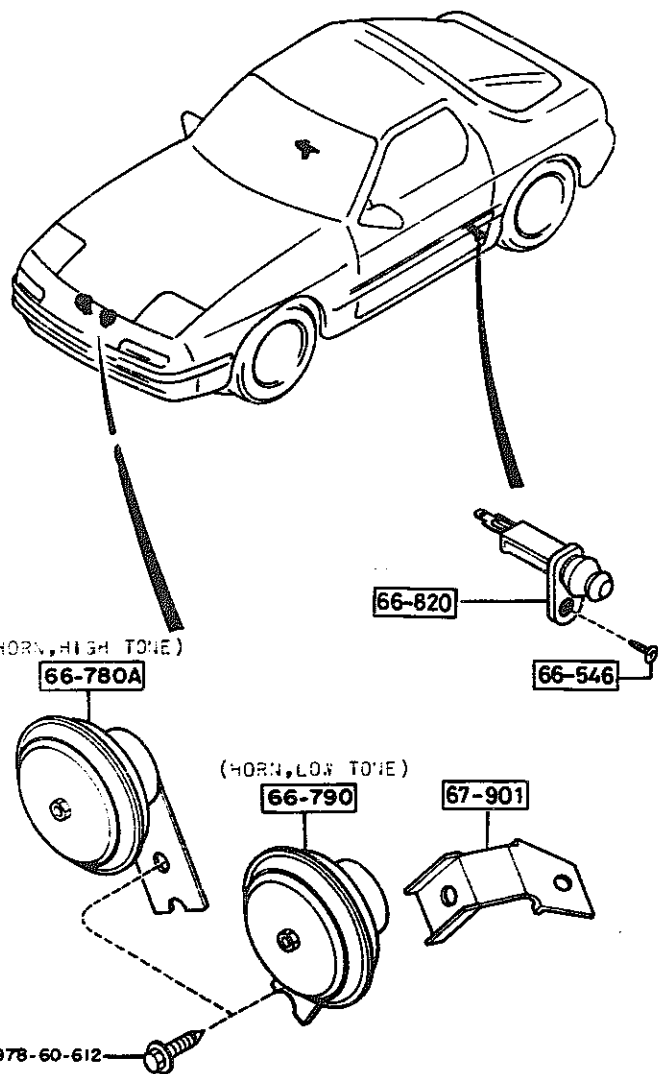

PART NO.	QTY	MODEL/RESTRICTION	MODEL/RESTRICTION	MODEL/RESTRICTION	FROM-TO
66-546		SCREW, DOOR SWITCH			
LAC1-66-546	2				
66-780A		HORN, HIGH TONE			
FB03-66-780	1				
66-790		HORN, LOW TONE			
FB01-66-790	1				
66-820		SWITCH, DOOR			
FB02-66-540	2				
67-901		BRACKET, HORN			
FB05-66-792	1				

-0201

0201-

1992-05

AUFA02

CAT. AUFA02-06

1992-05

4-D 6

6640 AUTO CRUISE CONTROL SYSTEM

FROM-TO

(W/O TURBO)

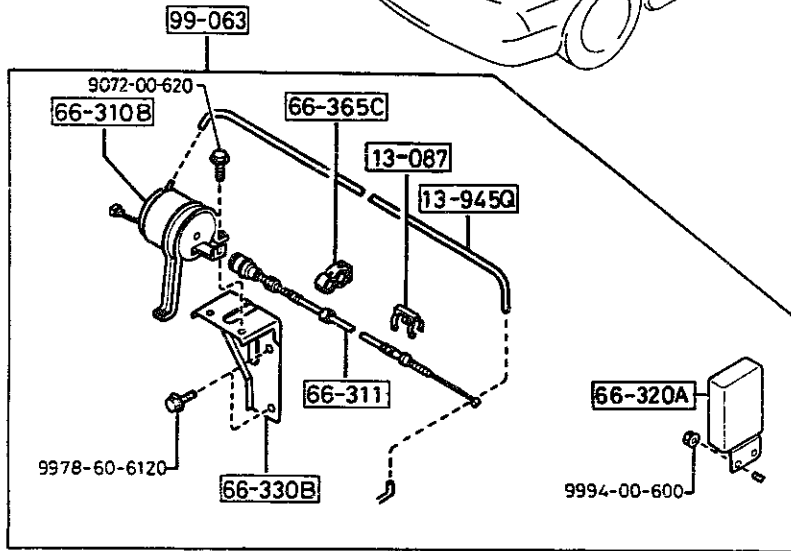

(TURBO)

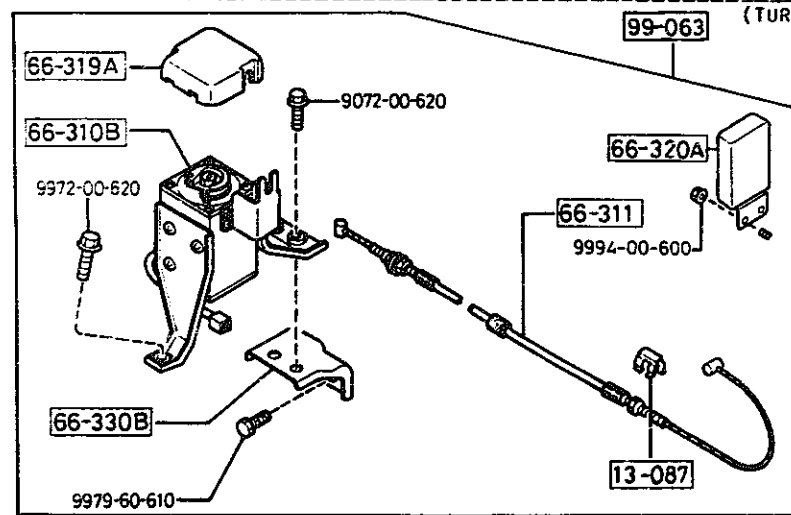

PART NO.	QTY	MODEL/RESTRICTION	MODEL/RESTRICTION	MODEL/RESTRICTION	FROM-TO
13-087		SPRING			
8871-13-087A	1				
13-945Q		PIPE			
FC01-66-361	1	(W/O TURBO)			
66-310B		ACTUATOR, A.C.C.			
FB01-66-310A	1	(W/O TURBO)			
F046-66-310B	1	(TURBO)			
66-311		WIRE, A.C.C.			
FB44-66-311A	1	(TURBO)			
FC01-66-311	1	(W/O TURBO)			
66-319A		COVER, ACTUATOR			
B107-66-319	1	(TURBO)			
66-320A		UNIT, A.C. CONTROL			
FC01-66-320A	1	(W/O TURBO)			
FC17-66-320A	1	(TURBO)			
66-330B		BRACKET, A.C.C. BOX			
FB01-66-330	1	CALIF, (W/O SUBU ZERO SYSTEM)			
FB02-66-330	1	FED, (W/SUBU ZERO SYSTEM)			
66-365C		CLIP			
UB40-66-365	2	(W/O TURBO)			
99-063		A.C.C. SET			
8AF3-66-340	1	(W/O TURBO)			
8AF4-66-340	1	(TURBO)			

CAT. AUFA02-06

1992-05

(AM/FM,W/O EQU.W/O C.D.)

(THIS ILLUSTRATION CONSISTS OF 3 PAGES)

(AM/FM/CASSET COMB.W/EQU.W/O C.D.)

(THIS ILLUSTRATION CONSISTS OF 3 PAGES)

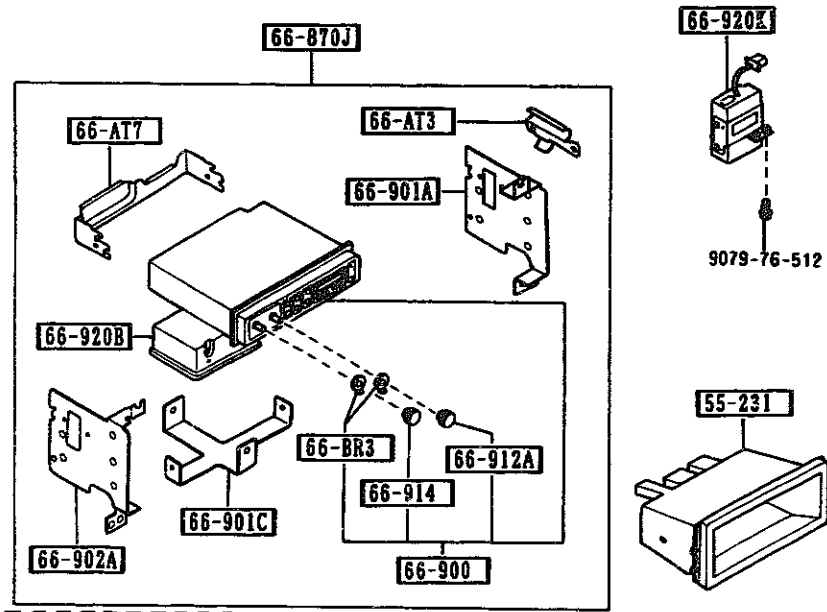

(AM/FM/CASSET COMB.W/O EQU.&C.D.)

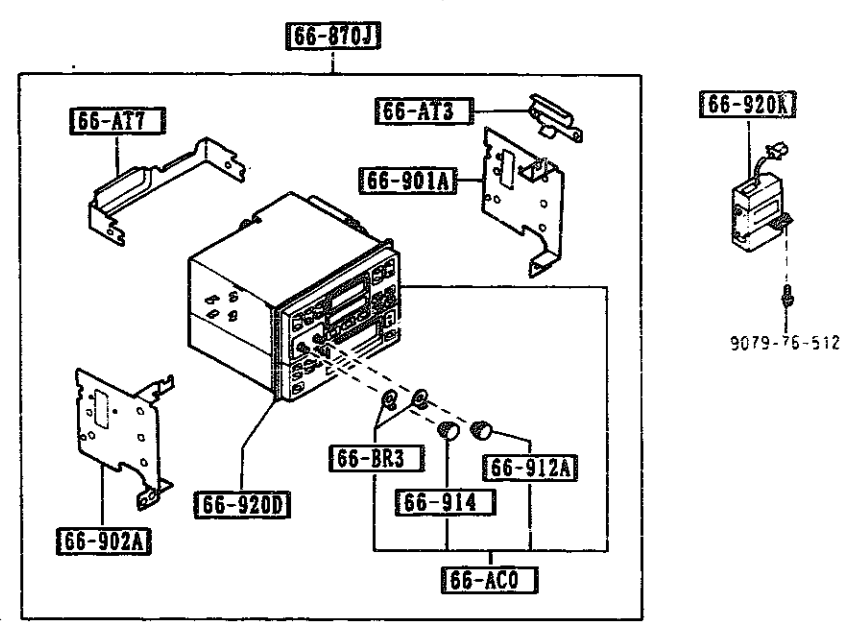

(AM/FM/CASSET COMB.W/EQU.W/C.D.)

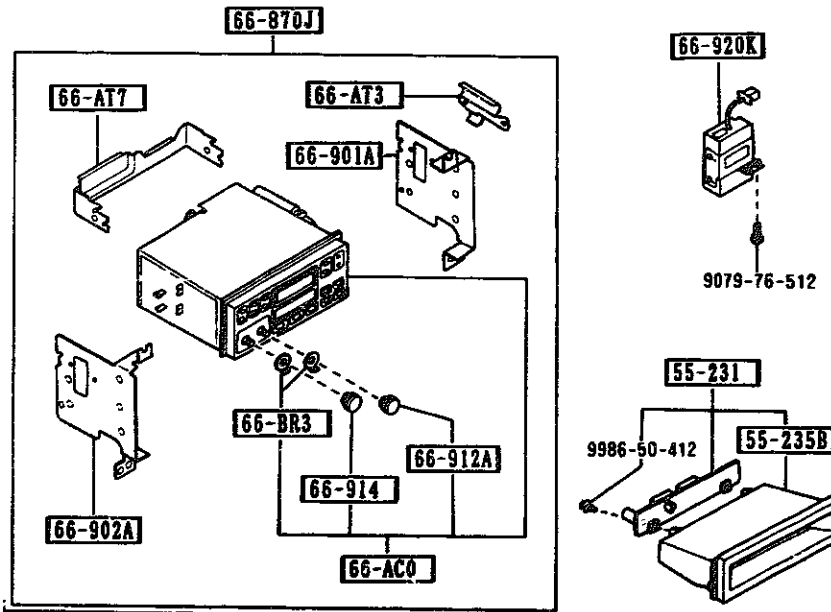

(CONT'D)

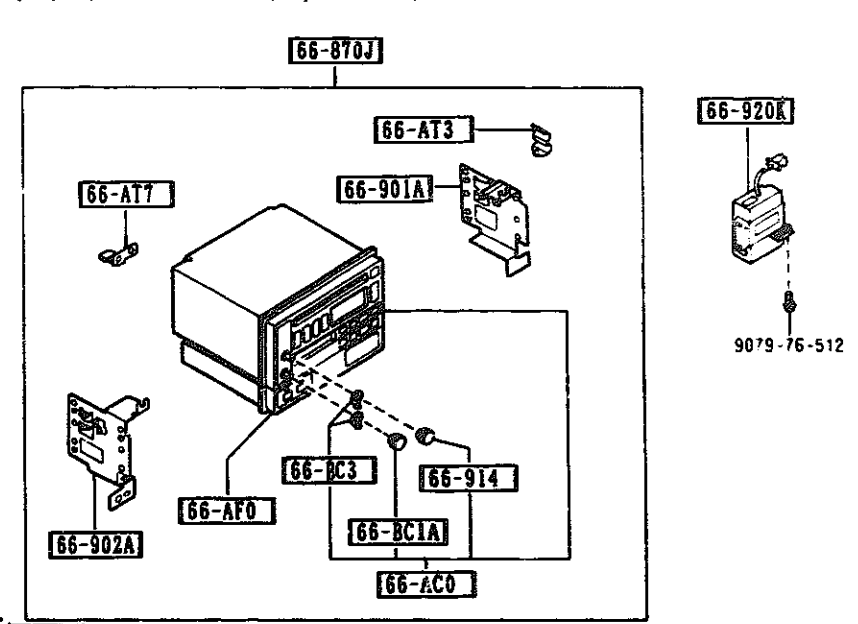

(CONT'D)

FROM-TO

1992-05

AUFA02

AUFA02

(THIS ILLUSTRATION CONSISTS OF 3 PAGES)



(AM/FM, W/O EQU, W/O C.D.)



(AM/FM/CASSET COMB. W/O EQU. & C.D.)

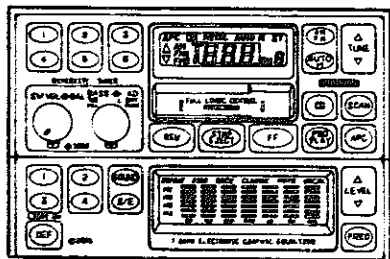

(AM/FM/CASSET COMB. W/EQU. W/O C.D.)

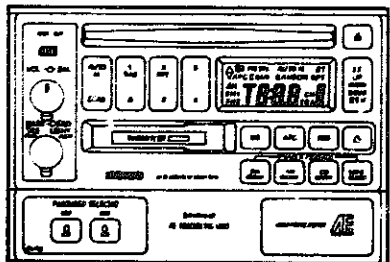

(AM/FM/CASSET COMB. W/EQU. W/C.D.)

(AM/FM, W/O EQU. W/O C.D.)

(THIS ILLUSTRATION CONSISTS OF 3 PAGES)

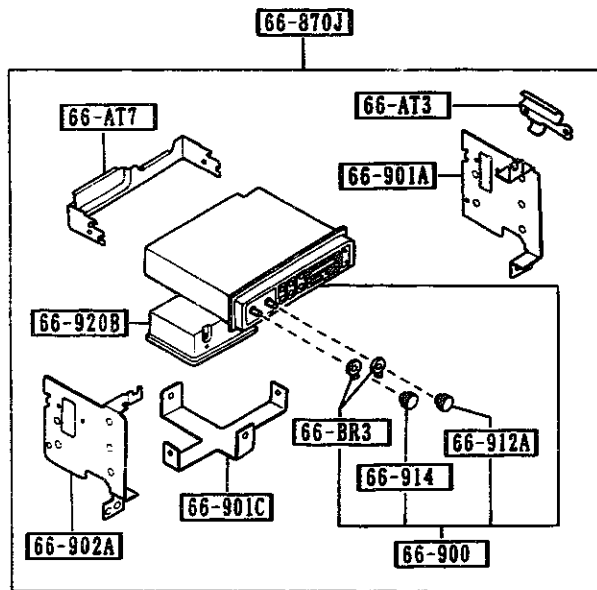

66-920K



9079-76-512

55-231

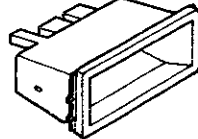

(AM/FM/CASSET COMB. W/O EQU. & C.D.)

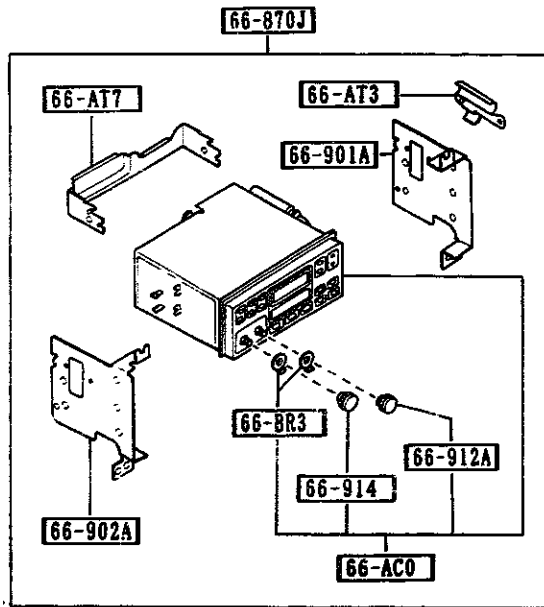

66-920K



9079-76-512

55-231

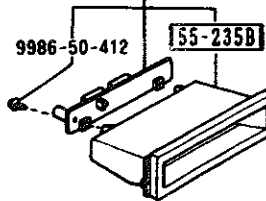

PART NO.	QTY	MODEL/RESTRICTION	MODEL/RESTRICTION	MODEL/RESTRICTION	FROM-TO
55-231		ORNAMENT, STEREO			
FC03-55-23Y	1	GTU, (AM/FM/DECK, W/O EQU. W/O C.DISK)			
FC04-55-235	1	GTUS, (AM/FM, W/O DECK, W/O EQU. W/O C.D)			
55-235B		ORNAMENT, STEREO-UPPER			
FC03-55-235	1	GTU, (AM/FM/DECK, W/O EQU. W/O C.DISK)			
66-AC0		TUNER & DECK, COMB.			
FC04-66-AC0	1	GXL-OPT, TURBO-OPT, (W/DECK, W/C.DISK)			
FC03-66-AC0 A (FC03-66-AC0A)	1				-9801
FC07-66-AC0A	1	GTU, GXL, TURBO, (W/DECK, W/O C.DISK)			9801-
66-AF0		CONTROLLER, AE SYSTEM -DISC			
FC04-66-AF0	1	GXL-OPT, TURBO-OPT, (W/COMPACT DISC)			
66-AT3		BRACKET(R), ANTENNA			
FB03-66-AT3	1	GTU, GTUS, GXL, TURBO, (W/O COMPACT DISC)			
FC32-66-AT3	1	GXL-OPT, TURBO-OPT, (W/COMPACT DISC)			
66-AT7		BRACKET(RR), AUDIO			
FC01-66-AT7	1	GTU, GTUS, GXL, TURBO, (W/O COMPACT DISC)			
FC04-66-AT7	1	GXL-OPT, TURBO-OPT, (W/COMPACT DISC)			
66-BC1A		KNOB, TONE-TUNER & DECK			
LA05-66-BC3	1	GXL-OPT, TURBO-OPT, (W/COMPACT DISC)			
66-BC3		KNOB, BALANCE-TUNER & DACK			
LA05-66-BC2	2	GXL-OPT, TURBO-OPT, (W/COMPACT DISC)			
9801 FC3***N-800894					

-9801

9801-

1992-05

1992-05

AUFA02

(CONT'D)

CAT. AUFA02-06

6680 AUDIO SYSTEMS (RADIO & TAPE DECK)
(COUPE)

(2/3)

(AM/FM/CASSET COMB.W/EQU.W/O C.D.) (THIS ILLUSTRATION CONSISTS OF 3 PAGES)

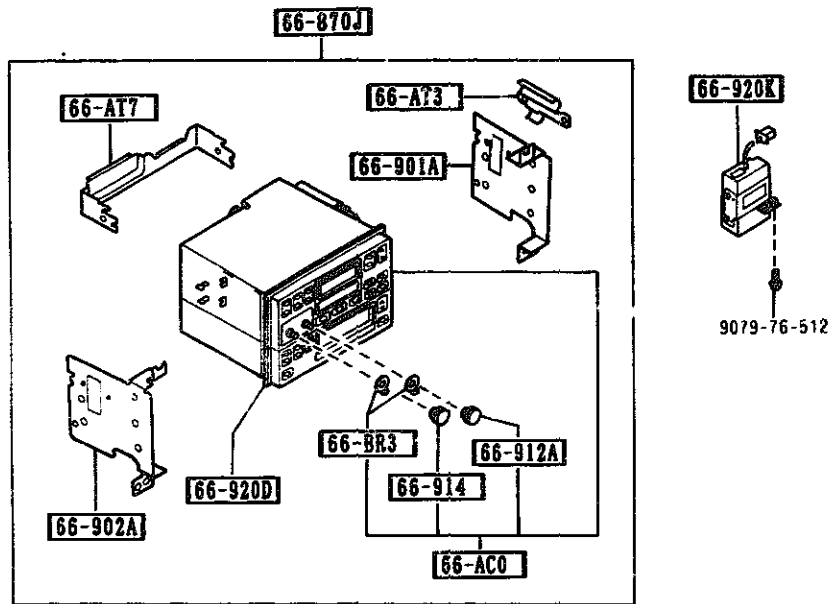

(AM/FM/CASSET COMB.W/EQU.W/C.D.)

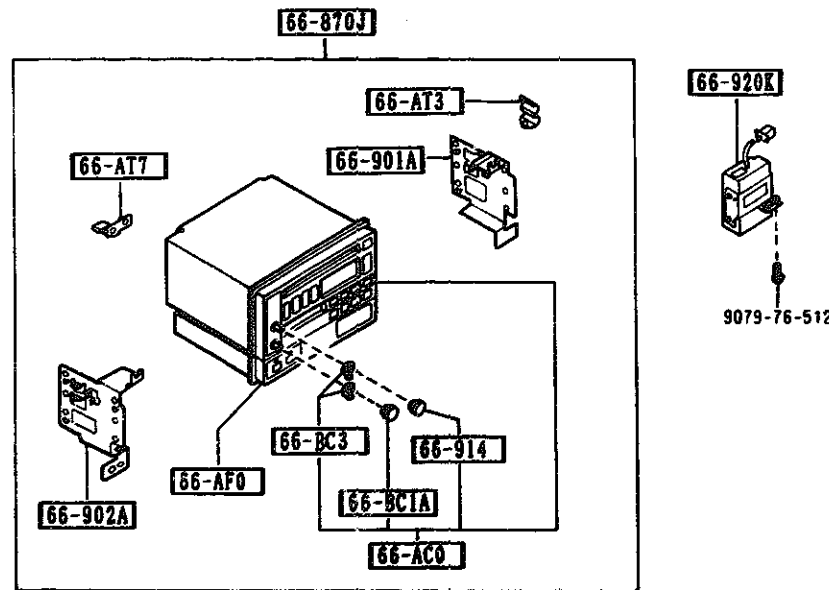

(CONT'D)

6680 -2 AUDIO SYSTEMS (RADIO & TAPE DECK)
(COUPE)

PART NO.	QTY	MODEL/RESTRICTION	MODEL/RESTRICTION	MODEL/RESTRICTION	FROM-TO
66-BR3		KN3B, BALANCE-TUNER			
FC01-66-BR3	2	GTU, GTUS, GXL, TURBO, (W/O COMPACT DISC)			
66-870J		AUDIO SET			
FC04-66-9WD	1	GXL-OPT, TURBO-OPT, (AM/FM/DECK.W/EQU.W/ C.DISK)			
FC02-66-9CD A (FC02-66-9CDA)	1				-9801
FC01-66-9S0 A (FC01-66-9S0A)	1				-9801
FC03-66-9WD A (FC03-66-9WDA)	1				-9801
FC02-66-9C0A	1	GTU, (AM/FM/DECK.W/O EQU. W/O C.DISK)			9801-
FC01-66-9S0A	1	GTUS, (AM/FM.W/O DECK.W/O EQU.W/O C.D)			9801-
FC03-66-9WDA	1	GXL, TURBO, (AM/FM/DECK.W/EQU.W/ O C.DISK)			9801-
66-900		TUNER			
FC01-66-AR0 A (FC01-66-AR0A)	1				-9801
FC01-66-ARDA	1	GTUS, (AM/FM.W/O DECK.W/O EQU.W/O C.D)			9801-
66-901A		BRACKET(R), TUNER			
FC01-66-AT1	1	GTU, GTUS, GXL, TURBO, (W/O COMPACT DISC)			
FC32-66-AT1	1	GXL-OPT, TURBO-OPT, (W/COMPACT DISC)			
66-901C		BRACKET, AMP			
FC01-66-AT4	1	GTUS, (AM/FM.W/C DECK.W/O EQU.W/O C.D)			
66-902A		BRACKET(L), TUNER			
FC01-66-AT2	1	GTU, GTUS, GXL, TURBO, (W/O COMPACT DISC)			
9801 FCSMXX-800894					

CAT. AUFA02-06

1992-05

(THIS ILLUSTRATION CONSISTS OF 3 PAGES)

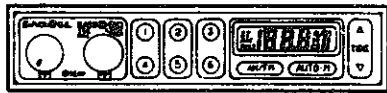

(AM/FM, W/O EQU. W/O C.D.)

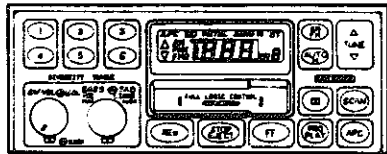

(AM/FM/CASSET COMB. W/O EQU. & C.D.)

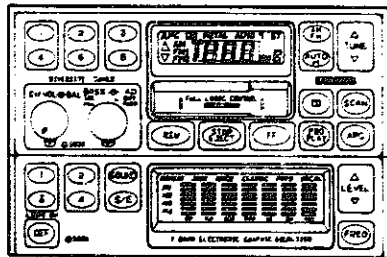

(AM/FM/CASSET COMB. W/EQU. W/O C.D.)

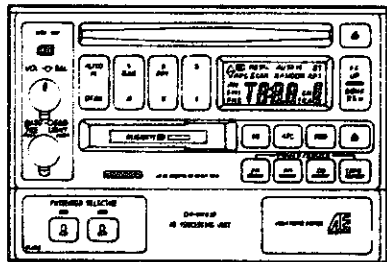

(AM/FM/CASSET COMB. W/EQU. W/C.D.)

PART NO.	QTY	MODEL/RESTRICTION	MODEL/RESTRICTION	MODEL/RESTRICTION	FROM-TO
CONT'D FC32-66-AT2	1	GXL-OPT, TURBO-OPT, (W/COMPACT DISC)			
		66-912A			
		66-912A	KNOB, TONE-TUNER		
FC01-66-BR2	1	GTU, GTUS, GXL, TURB O, (W/O COMPACT DISC)			
		66-914			
		66-914	KNOB, VOLUME-TUNER		
FC04-66-BC1	1	GXL-OPT, TURBO-OPT, (W/COMPACT DISC)			
FC01-66-BR1	1	GTU, GTUS, GXL, TURB O, (W/O COMPACT DISC)			
		66-920B			
		66-920B	AMP, POWER-AUDIO		
FC01-66-920	1	GTUS, (AM/FM, W/O DECK, W/O EQU. W/O C.D)			
		66-920D			
		66-920D	EQUALIZER, GRAPHIC		
FC03-66-AE0	1	GXL, TURBO, (AM/FM/DECK, W/EQU. W/ O C.DISC)			
		66-920K			
		66-920K	AMP, WOOFER-AUDIO		
FC04-66-920	1	GXL-OPT, TURBO-OPT, (W/COMPACT DISC)			
FC02-66-920 A (FC02-66-920A)	1				-9822
FC02-66-920A	1	GTU, GTUS, GXL, TURB O, (W/O COMPACT DISC)			9822-
9822 FC3MM-801600					

FROM-TO

1992-05

AUFA02

CAT. AUFA02-06

1992-05

6680 A AUDIO SYSTEMS (RADIO & TAPE DECK)
(CONVERTIBLE)

6680 A-1 AUDIO SYSTEMS (RADIO & TAPE DECK)
(CONVERTIBLE)

FROM-TO

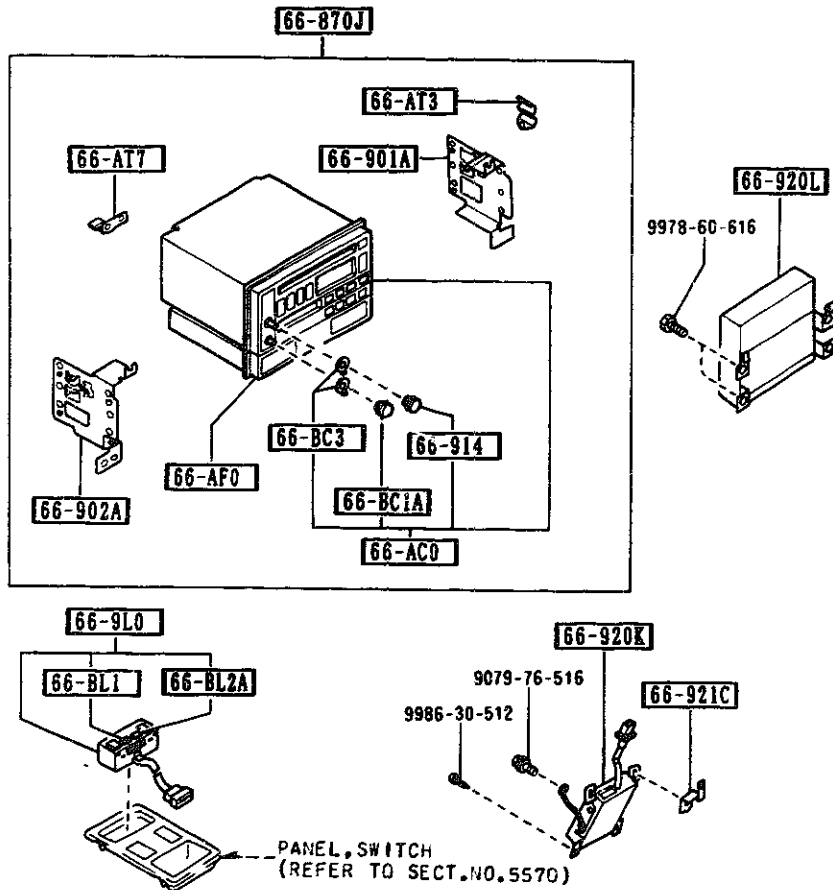

PART NO.	QTY	MODEL/RESTRICTION	MODEL/RESTRICTION	MODEL/RESTRICTION	FROM-TO
66-AC0		TUNER & DECK, COMB.			
FC04-66-AC0	1				
66-AF0		CONTROLLER, AE SYSTEM -DISC			
FC32-66-AF0	1	(W/O AIR BAG)			
FC66-66-AF0	1	(W/AIR BAG)			
66-AT3		BRACKET(R), ANTENNA			
FC32-66-AT3	1				
66-AT7		BRACKET(RR), AUDIO			
FC04-66-AT7	1				
66-BC1A		KNOB, TONE-TUNER & DECK			
LA05-66-BC3	1				
66-BC3		KNOB, BALANCE-TUNER & DACK			
LA05-66-BC2	2				
66-BL1		KNOB, VOL.-REMOTE CONTROL			
F055-66-BL1	1				
66-BL2A		KNOB, SURROUND-REMOTE CONTROL			
F055-66-BL2	1				
66-870J		AUDIO SET			
FC32-66-9W0	1	(W/O AIR BAG)			
FC66-66-9W0	1	(W/AIR BAG)			
66-9L0		CONTROL, REMOTE-AUDIO			
F055-66-9L0A	1				
66-901A		BRACKET(R), TUNER			
FC32-66-AT1	1				
66-902A		BRACKET(L), TUNER			
FC32-66-AT2	1				
66-914		KNOB, VOLUME-TUNER			
FC04-66-BC1	1				

1992-05

AUFA02

CAT. AUFA02-06

1992-05

4-K 6

6680 A AUDIO SYSTEMS (RADIO & TAPE DECK)
(CONVERTIBLE)

6680 A-2 * AUDIO SYSTEMS (RADIO & TAPE DECK)
(CONVERTIBLE)

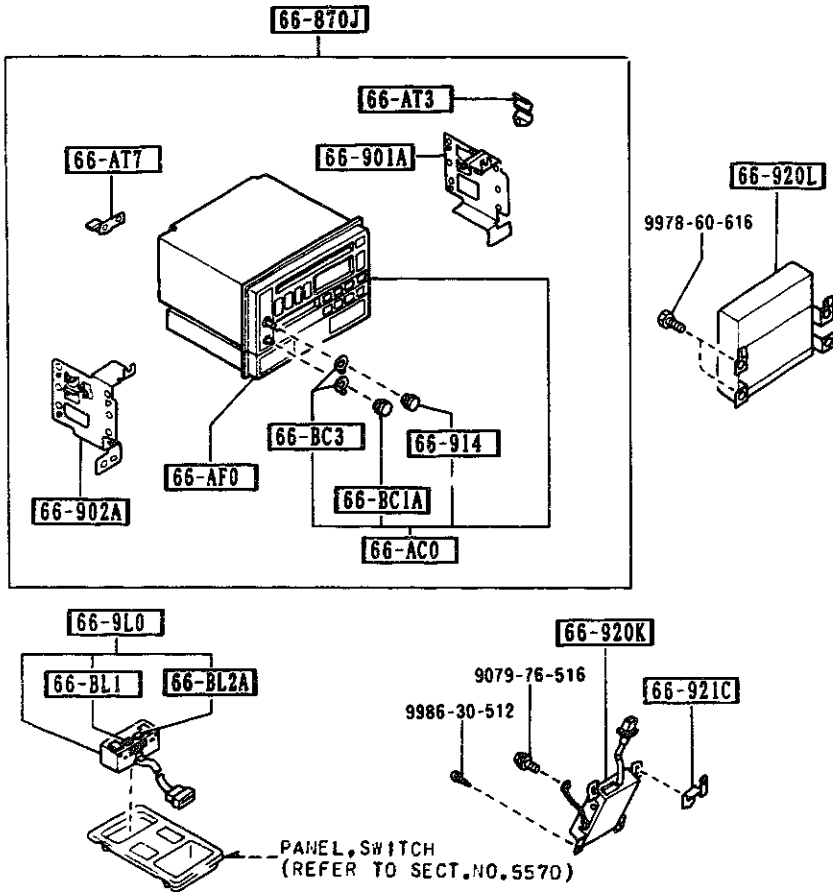

PART NO.	QTY	MODEL/RESTRICTION	MODEL/RESTRICTION	MODEL/RESTRICTION	FROM-TO
66-920K		AMP, WOODFER-AUDIO			
FC14-66-920	1	(W/O AIR BAG)			
FC66-66-920	1	(W/AIR BAG)			
66-920L		AMP, PILLOW-AUDIO			
FC32-66-920	1				
66-921C		BRACKET, AMP-AE SYSTEM			
FB76-66-921	1	(W/O AIR BAG)			

POM-TO

1992-05

AUFA02

CAT. AUFA02-06

1992-05

FFGM-10

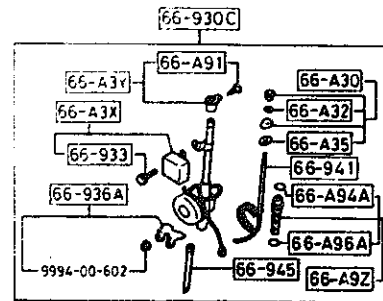
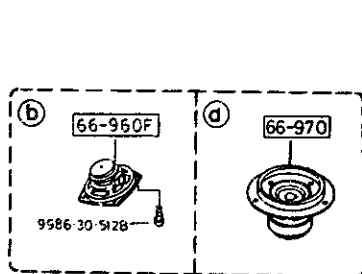
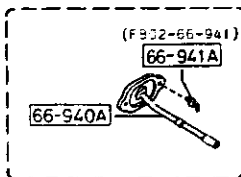
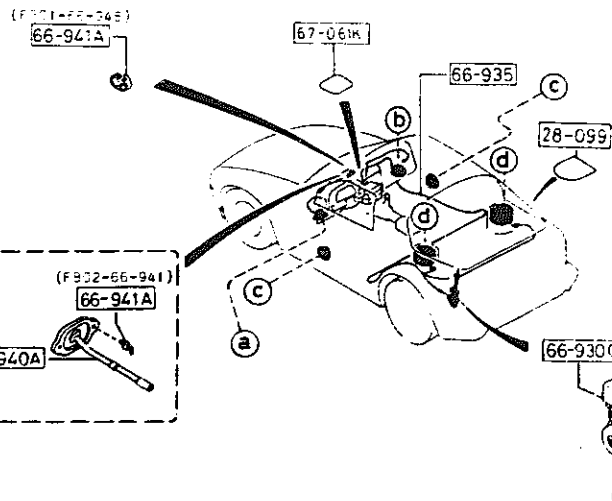
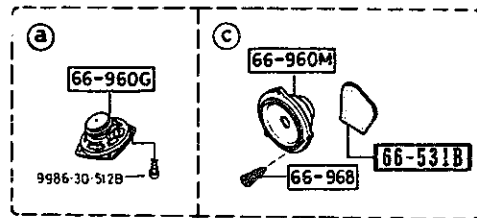

PART NO.	QTY	MODEL/RESTRICTION	MODEL/RESTRICTION	MODEL/RESTRICTION	FROM-TO
28-099		PAD, REAR SUSPENSION			
FB01-28-099	2				
66-A3X		RELAY, MOTOR-ANTENNA			
FB01-66-A3X	1				-0401
HE02-66-A3X	1				0401-
66-A3Y		PLATE, EARTH-MOTOR AN TENNA			
FB01-66-A3Y	1				
66-A30		NUT, MOUNTING-ANTENNA			
FB01-66-A30	1				
66-A32		RING, 'O'-MOUNTING AN TENNA			
FB01-66-A32	1				
66-A35		PAD, MOUNTING-ANTENNA			
FB01-66-A35	1				
66-A9Z		INSULATOR, ROD-ANTENN A			
HE02-66-A9Z	1				
66-A91		SCREW, EARTH PLATE-AN TENNA			
FB01-66-A91	1				
66-A94A		RING, 'O'-ANTENNA			
HE02-66-A94	1				
66-A96A		RING, 'O'-ANTENNA			
HE02-66-A96	1				
66-531B		PAD			
FC01-66-9B6	2				
66-930C		ANTENNA, MOTOR-RADIO			
FB01-66-930A AN(FB01-66-930B)	1				-0401
FB01-66-930B	1				0401-
66-933		SCREW, ANTENNA			
FB01-66-A92	1				

0401 FC3***-806597

-9A01

AD01-

-0302

302-

1992-05

AUFA02

CAT. AUFA02-06

1992-05

4-M 6

FPGM-TG

-9501

501-

-9501

501-

1992-05

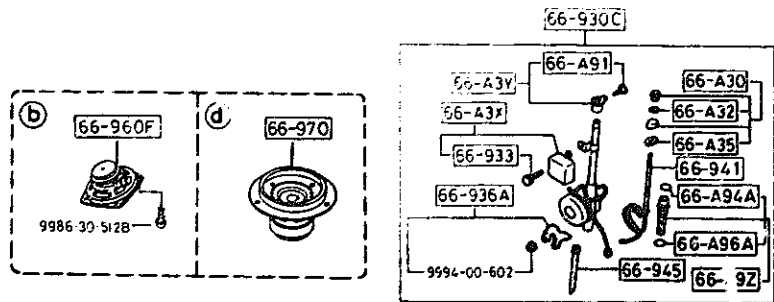
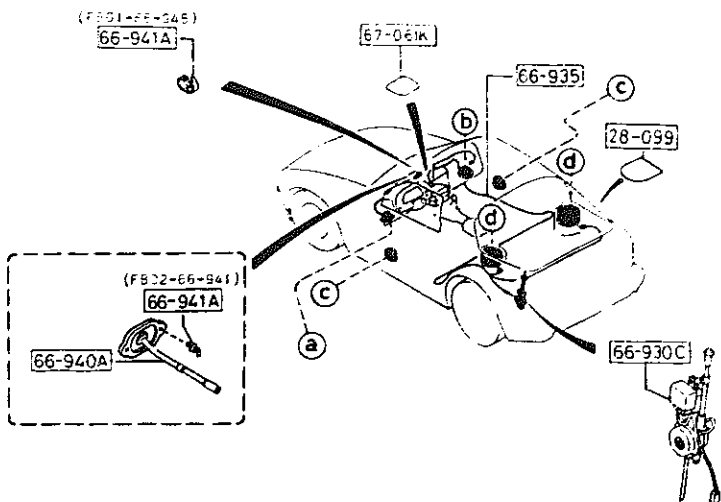
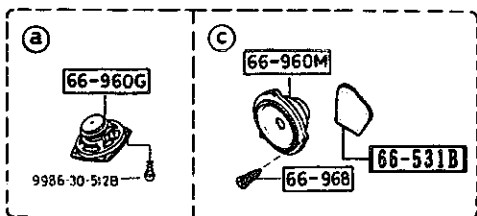

PART NO.	QTY	MODEL/RESTRICTION	MODEL/RESTRICTION	MODEL/RESTRICTION	FROM-TG
66-935		FEEDER-ANTENNA			
FC01-66-940B	1				
66-936A		BRKT.MOTOR-ANTENA			
FB01-66-A9X	1				
66-940A		FEEDER & COVER			
FB02-66-940B	1				
66-941		POLE,ANTENNA			
FB01-66-A90	1				
66-941A		CLIP			
FB02-66-941	2				
FB01-66-945	1				
66-945		PIPE			
FB01-66-A9Y	1				
66-9		SPEAKER(R),LOUD-FRT			
FC02-66-940A	1	GTU, GTUS, GXL, TURB D. (W/O COMPACT DISC)			
FC03-66-960A	1	GXL-OPT, TURBO-OPT, (W/COMPACT DISC)			
66-960G		SPEAKER(L),LOUD-FRONT			
FC01-66-960	1	GTU, GTUS, GXL, TURB D. (W/O COMPACT DISC)			
FC04-66-960	1	GXL-OPT, TURBO-OPT, (W/COMPACT DISC)			
66-960M		SPEAKER,DOOR			
FC07-66-960	2	GTUS, GTU. (AM/FM,W/O DECK,W/O EQU,W/O C.D) (AM/FM/DECK,W/O EQU, W/O C.DISC)			
FC08-66-960	2	GXL-OPT, TURBO-OPT, (AM/FM/DECK,W/EQU,W/ C.DISC)			
FC12-66-960	2	GXL, TURBO. (AM/FM/DECK,W/EQU,W/ D C.DISC)			

SECTION NAME INDEX (BODY) 2/2

LO.NO	SEC.NO	SECTION NAME	LO.NO	SEC.NO	SECTION NAME	LO.NO	SEC.NO	SECTION NAME
4-C03	6100	HEATER	4-E08	6703	WIRING HARNESSSES(DOOR,FLOOR/CEILING)			
4-E03	6110	HEATER UNIT COMPONENTS	4-G08	6704	WIRING HARNESS CLAMPS			
4-F03	6115	HEATER CONTROLS COMPONENTS	4-J08	6720	WINDSHIELD WASHER (1.5L & 2.5L)			
4-G03	6120	HEATER BLOWER COMPONENTS	4-L08	6720 A	WINDSHIELD WASHER (5.7L)			
4-I03	6130	AIR CONDITIONER	4-N08	6730	WINDSHIELD WIPERS			
4-J03	6230	LIFT GATE MECHANISMS (COUPE)	4-C09	6740	WIPER MOTOR COMPONENTS(FRONT)			
4-M03	6300	WINDOW GLASSES (COUPE)	4-D09	6750	WINDOW WIPER & WASHER (REAR)			
4-N03	6300A	WINDOW GLASSES (CONVERTIBLE)	4-G09	6760	WINDOW WIPER MOTOR COMPONENTS (REAR)			
4-C04	6330	SUNROOF (COUPE)	4-H09	6800	CEILING TRIMS (COUPE)			
4-G04	6330A	SUNROOF (CONVERTIBLE)	4-J09	6800A	CEILING TRIMS (CONVERTIBLE)			
4-M04	6600	SWITCHES & RELAYS (ENGINE)	4-K09	6810	ROLLEBAR (CONVERTIBLE)			
4-G05	6610	DASHBOARD SWITCHES	4-N09	6820	PILLAR TRIMS (COUPE)			
4-H05	6611	COMBINATION SWITCH	4-F10	6820A	PILLAR TRIMS (CONVERTIBLE)			
4-I05	6612	CLUSTER SWITCH	4-G10	6840	TRIMS & SCUFF PLATES (COUPE)			
4-L05	6615	POWER WINDOW SWITCHES	4-L10	6840A	TRIMS & SCUFF PLATES (CONVERTIBLE)			
4-M05	6630	RELAYS & UNIT (BODY)	4-N10	6845	STRAGE BOX (COUPE)			
4-D06	6635	DOOR SWITCH & HORNS			(GXL.TURBO)			
4-E06	6640	AUTO CRUISE CONTROL SYSTEM	4-D11	6860	FLOOR MATS & PADS (COUPE)			
4-F06	6680	AUDIO SYSTEMS (RADIO & TAPE DECK) (COUPE)	4-K11	6860A	FLOOR MATS & PADS (CONVERTIBLE)			
4-K06	6680 A	AUDIO SYSTEMS (RADIO & TAPE DECK) (CONVERTIBLE)	4-C12	6870	SERVICE TOOLS			
4-M06	6682	AUDIO SYSTEMS (ANTENNA & SPEAKER) (COUPE)	4-D12	6900	VISORS,ASSIST HANDLES & MIRRORS (COUPE)			
4-D07	6682 A	AUDIO SYSTEMS (ANTENNA & SPEAKER) (CONVERTIBLE)	4-H12	6900A	VISORS,ASSIST HANDLES & MIRRORS (CONVERTIBLE)			
4-G07	6684	AUDIO SYSTEMS(NOISE SUPPRESSOR & EARTH CORD)	4-K12	6930	CAUTION PLATES & LABELS			
4-H07	6700	WIRING HARNESSSES(FRONT & REAR)	4-L12	7250	QUARTER WINDOW & TRIMS			
4-N07	6701	WIRING HARNESSSES(ENGINE & T/MISSION)	4-L13	7800	SPOILERS & RELATED PARTS			
4-D08	6702	WIRING HARNESSSES(DASHBOARD)	4-C14	7900	ACCESSORIES			

CATLOG-NO= AUFA02-06

DATE. 1992-05

4-B 7

FROM-TO

9501-

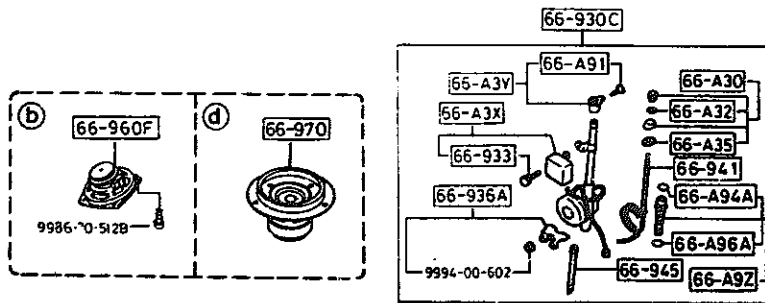
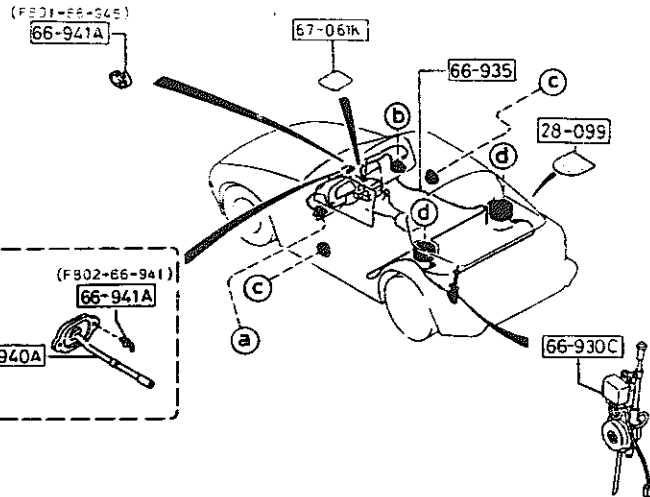
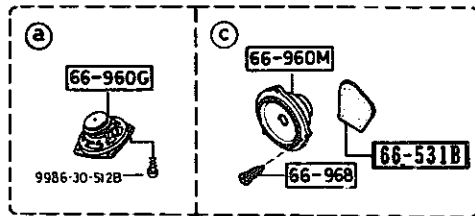

PART NO.	QTY	MODEL/RESTRICTION	MODEL/RESTRICTION	MODEL/RESTRICTION	FROM-TO
66-968		SCREW, LOUD SPEAKER-D			
FC02-66-968	6				
66-970		SPEAKER, LOUD-REAR			
FC09-66-960	2	GTU, GTUS, GXL, TURBO, (W/O COMPACT DISC)			
FC10-66-960	2	GXL-OPT, TURBO-OPT, (W/COMPACT DISC)			
67-061K		PAD, PROTECTOR			
G001-67-061	1				

1992-05

AUFA02

CAT. AUFA02-06

1992-05

4-C 7

6682 A AUDIO SYSTEMS (ANTENNA & SPEAKER)
(CONVERTIBLE)

6682 A-1 AUDIO SYSTEMS (ANTENNA & SPEAKER)
(CONVERTIBLE)

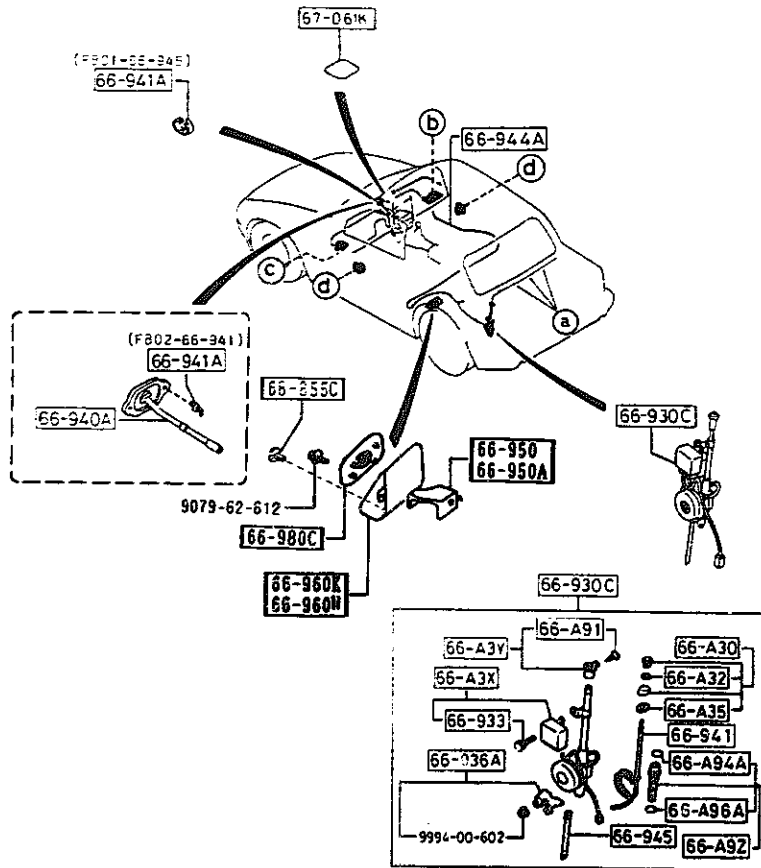
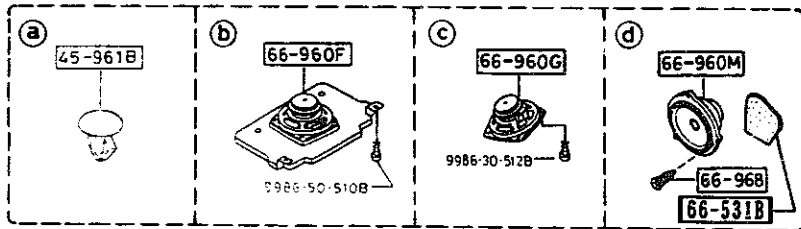

PART NO.	QTY	MODEL/RESTRICTION	MODEL/RESTRICTION	MODEL/RESTRICTION	FROM-TO
45-961B		CAP			
H002-45-961	3				
66-A3X		RELAY, MOTOR-ANTENNA			
HE02-66-A3X	1				
66-A3Y		PLATE, EARTH-MOTOR ANTENNA			
FB67-66-A3Y	1				
66-A30		NUT, MOUNTING-ANTENNA			
FB67-66-A30	1				
66-A32		RING, 'O'-MOUNTING ANTENNA			
FB01-66-A32	1				
66-A35		PAD, MOUNTING-ANTENNA			
FB67-66-A35	1				
66-A92		INSULATOR, ROD-ANTENNA			
HE02-66-A92	1				
66-A91		SCREW, EARTH PLATE-ANTENNA			
FB01-66-A91	1				
66-A94A		RING, 'O'-ANTENNA			
HE02-66-A94	1				
66-A96A		RING, 'O'-ANTENNA			
HE02-66-A96	1				
66-531B		PAD			
FC01-66-9B6	2				
66-930C		ANTENNA, MOTOR-RADIO			
FB67-66-930	1				
66-933		SCREW, ANTENNA			
FB01-66-A92	1				
66-936A		BRKT, MOTOR-ANTENNA			
FB01-66-A9X	1				

FROM-TO

1992-05

AUFA02

CAT. AUFA02-06

1992-05

4-D 7

6682 A AUDIO SYSTEMS (ANTENNA & SPEAKER)
(CONVERTIBLE)

6682 A-2 AUDIO SYSTEMS (ANTENNA & SPEAKER)
(CONVERTIBLE)

FROM-TO

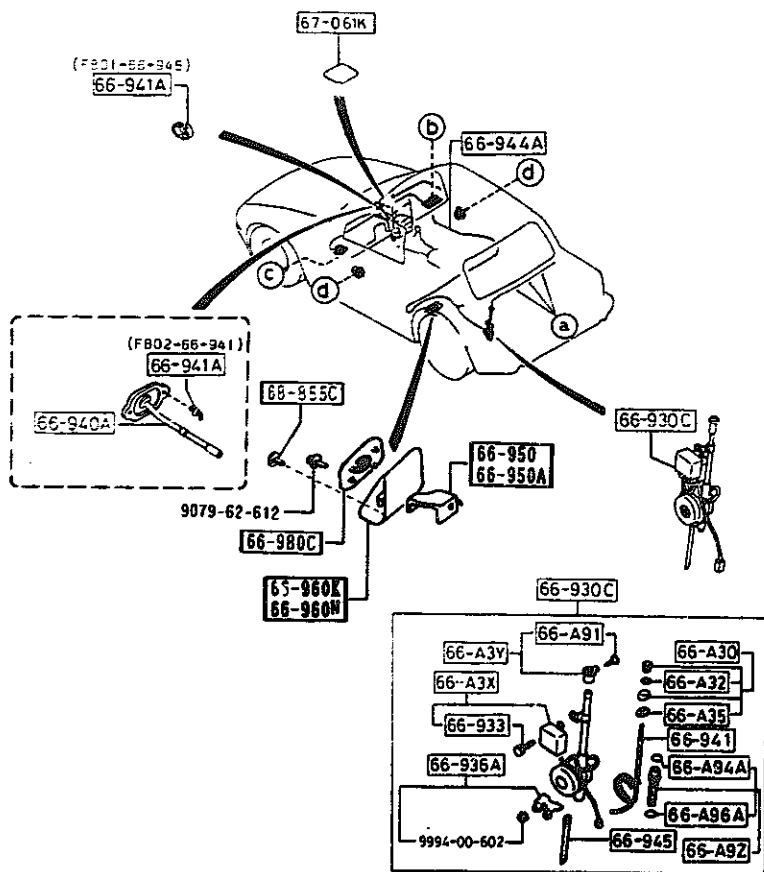
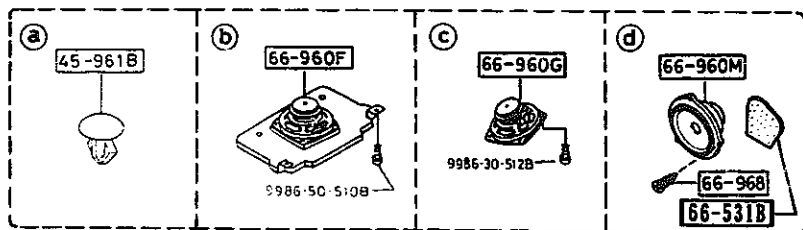

PART NO.	QTY	MODEL/RESTRICTION	MODEL/RESTRICTION	MODEL/RESTRICTION	FROM-TO
66-940A		FEEDER & COVER			
FB02-66-940B	1				
66-941		POLE, ANTENNA			
FB01-66-A90	1				
66-941A		CLIP			
FB02-66-941	2				
FB01-66-945	1				
66-944A		FEEDER, ANTENNA			
F868-66-940B	1				
66-945		PIPE			
FB01-66-A9Y	1				
66-950		BRACKET(R), SPEAKER			
FC66-66-98X	1	(W/AIR BAG)			
66-950A		BRACKET(L), SPEAKER			
FC67-66-98X	1	(W/AIR BAG)			
66-960F		SPEAKER(R), LOUD-FRT			
FC06-66-960	1	(W/O AIR BAG)			
66-960G		SPEAKER(L), LOUD-FRON			
FC04-66-960	1	(W/O AIR BAG)			
66-960K		SPEAKER(R), LOUD-RR			
*FC66-66-960A	1	(W/AIR BAG)			
66-960M		SPEAKER, DOOR			
FC08-66-960	2	(W/O AIR BAG)			
FC33-66-960	2	(W/AIR BAG)			
66-960N		SPEAKER(L), REAR			
*FC67-66-960A	1	(W/AIR BAG)			
66-968		SCREW, LOUD SPEAKER-D			
FC02-66-968	6	DOOR			

1992-05

AUFA02

CAT. AUFA02-06

1992-05

6682 A AUDIO SYSTEMS (ANTENNA & SPEAKER)
(CONVERTIBLE)

6682 A-3 * AUDIO SYSTEMS (ANTENNA & SPEAKER)
(CONVERTIBLE)

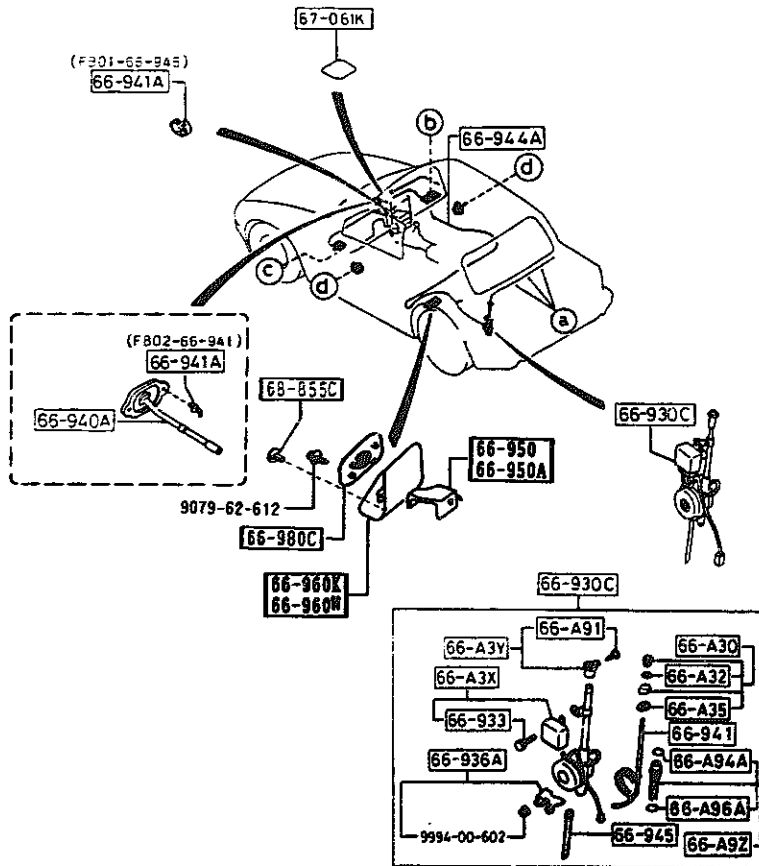
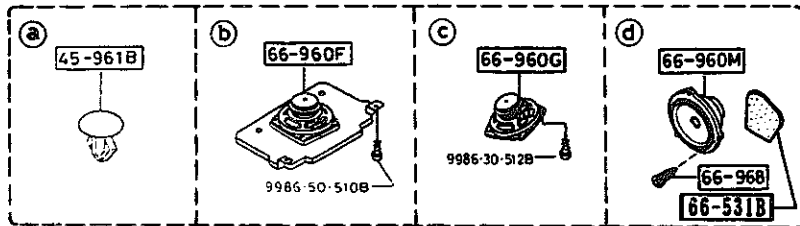

PART NO.	QTY	MODEL/RESTRICTION	MODEL/RESTRICTION	MODEL/RESTRICTION	FROM-TO
66-980C		GRILLE, SPEAKER			
*FC66-66-980A	2	(W/AIR BAG)			
* 02		FD8 BLACK			
* 48		FD9 BLUE			
67-061K		PAD, PROTECTOR			
G001-67-061	1				
68-855C		FASTENER			
*G043-68-865B	2	(W/AIR BAG)			
* 00		FE0 FE1 FD8 BLACK			
* 48		FD9 BLUE			

6684 AUDIO SYSTEMS(NOISE SUPPRESSOR & EARTH CORD)

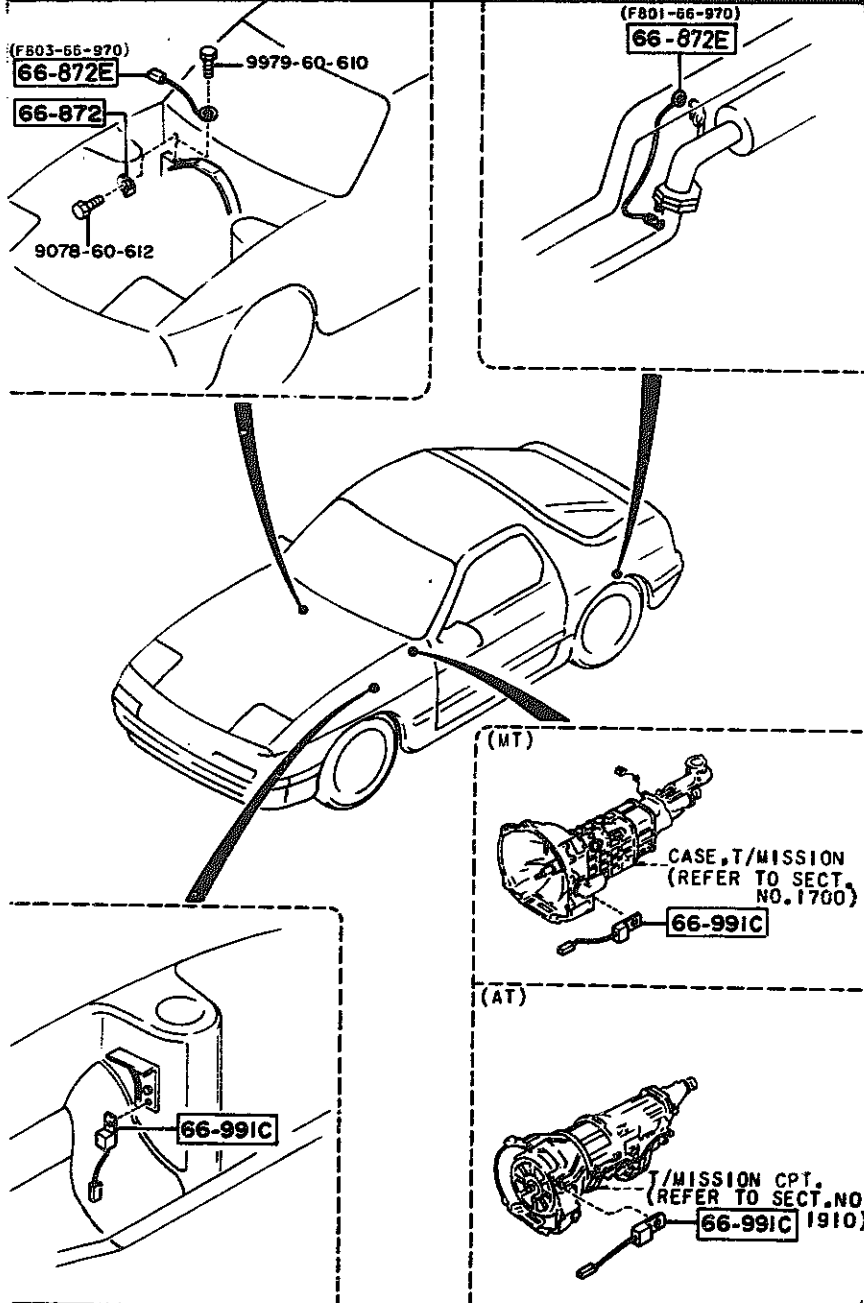

PART NO.	QTY	MODEL/RESTRICTION	MODEL/RESTRICTION	MODEL/RESTRICTION	FROM-TO
66-872		TAB, EARTH			
FB01-66-994A	1				
66-872E		CORD, EARTH			
FB01-66-970	1	T/M CASE - DASH.			
FB03-66-970	1	EX. PIPE - BODY			
66-991C		CONDENSER			
FB01-66-991B	2				

AUFA02

CAT. AUFA02-06

1992-05

(THIS ILLUSTRATION CONSISTS OF 2 PAGES)

(THIS ILLUSTRATION CONSISTS OF 2 PAGES)

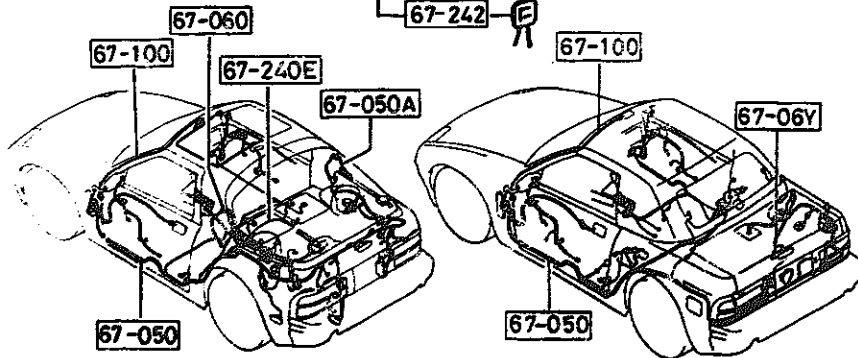
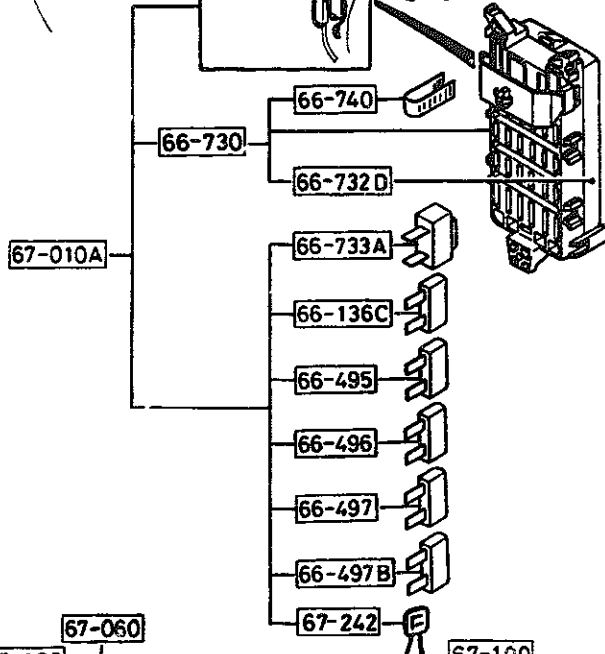
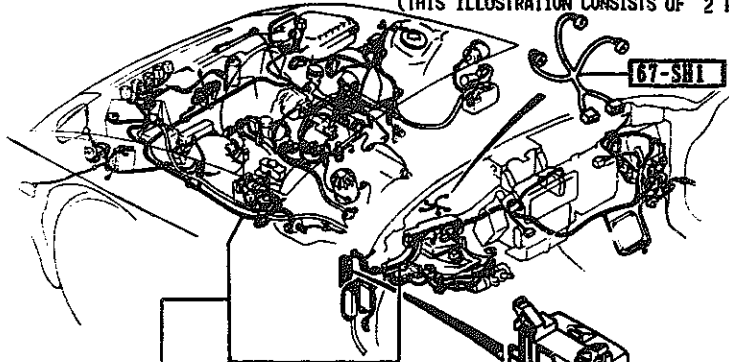

BODY	T/MISSION	A. A SUSP	DIFF	A LOCK BRAKE	AIR BAG	PARTS NUMBER
COPE	MT	-	NOR	※	※	FC01-67-010
			LS	-	-	※
		X		※	※	※
			AT	-	※	※
	AT	X		※	※	※
		CONVERTIBLE	MT	※	※	※
※	※			※	X	FC66-67-010
AT	※		※	※	-	FC47-67-010
	※		※	※	X	FC67-67-010

-9801

9801-

1992-05

AUFA02

(CONT'D)

AUFA02

4-H-7

6700 WIRING HARNESSES(FRONT & REAR)

(1/2)

FROM-TO

(THIS ILLUSTRATION CONSISTS OF 2 PAGES)

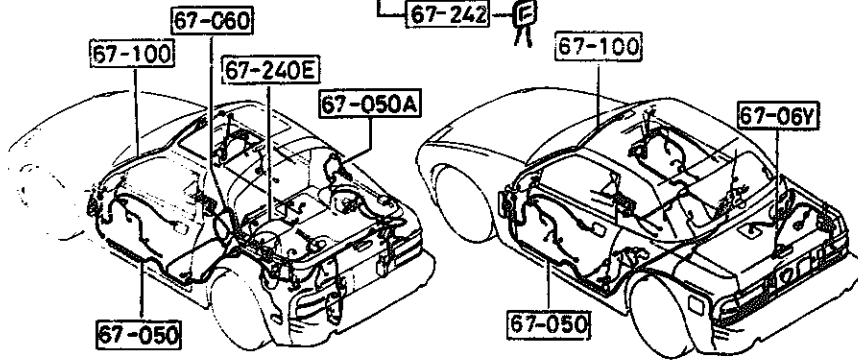
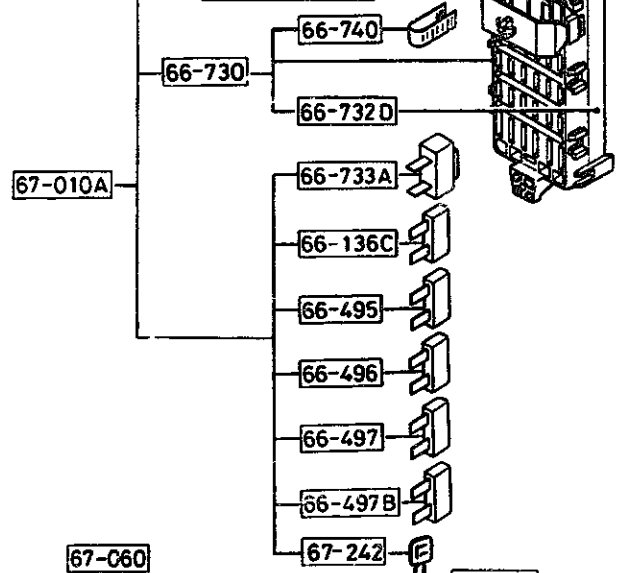
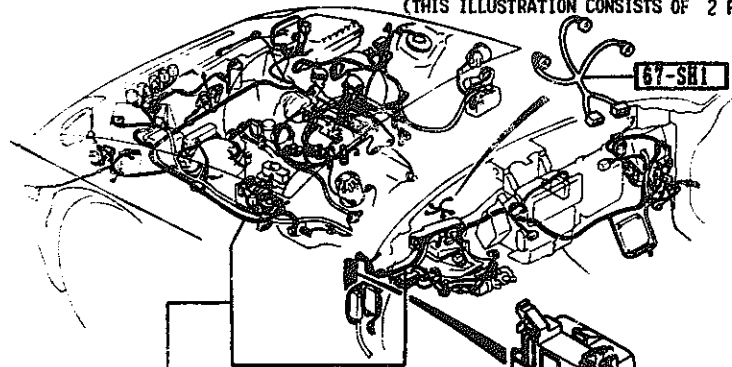

6700 -1 WIRING HARNESSES(FRONT & REAR)

PART NO.	QTY	MODEL/RESTRICTION	MODEL/RESTRICTION	MODEL/RESTRICTION	FROM-TO
66-136C		FUSE(7.5A)			
99705-1107	1				
66-495		FUSE(10A)			
99705-1110	7				
66-496		FUSE(15A)			
99705-1115	9				
66-497		FUSE(20A)			
99705-1120	3				
66-497B		FUSE(30A)			
99705-1130	2				
66-730		BLOCK,FUSE			
FC01-66-730	1	(W/O AIR BAG)			
FC66-66-730A	1	(W/AIR BAG)			
66-732D		COVER,FUSE BLOCK			
FC01-66-731	1	FURUKAWA (W/O AIR BAG)			
FC66-66-731	1	(W/AIR BAG)			
66-733A		BREAKER			
H001-66-733	2				
66-740		HOLDER,FUSE			
H001-66-739	1				
67-SH1		CORD,SHORT			
FC01-67-SH0C A (FC01-67-SH0D)	1				-9501
FC07-67-SH0C A (FC07-67-SH0D)	1				-9501
FC01-67-SH0D	1	(MT)			9501-
FC07-67-SH0D	1	(AT)			9501-
67-010A		HARNES,FRONT			
FC01-67-010C	1	(REFER TO THE CHART IN THE ILLUSTRATION)			-9501
9501 FC3MMN-707092					

-9801
-9801
-9801

9801-

9801-

9801-

-9801

9801-

-9501

-9501

9501-

9501-

-9501

1992-05

AUFA02

(CONT'D)

CAT. AUFA02-06

1992-05

6700 WIRING HARNESSSES(FRONT & REAR)

(1/2)

(THIS ILLUSTRATION CONSISTS OF 2 PAGES)

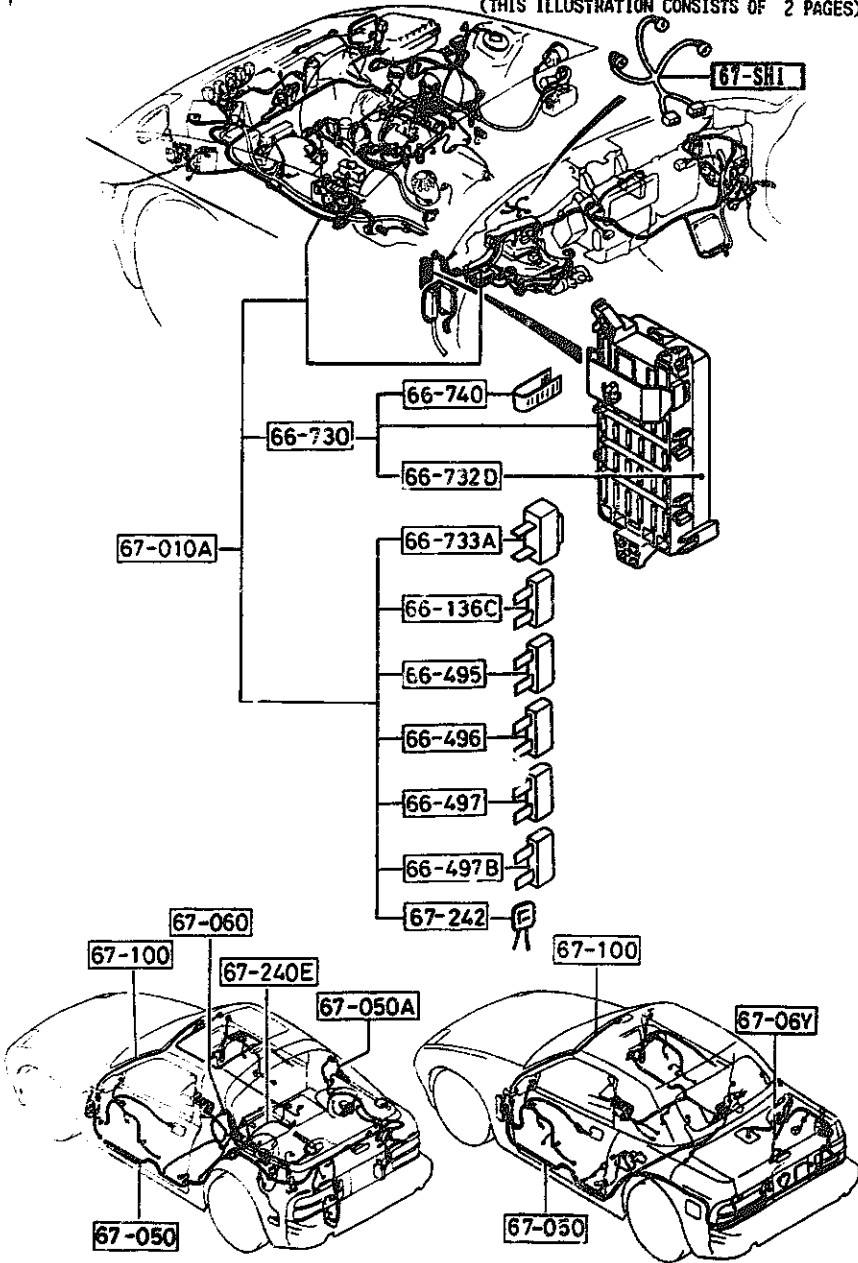

6700 -2 WIRING HARNESSSES(FRONT & REAR)

PART NO.	QTY	MODEL/RESTRICTION	MODEL/RESTRICTION	MODEL/RESTRICTION	FROM-TO
CONT'D FC02-67-010C	1	(REFER TO THE CHART IN THE ILLUSTRATION)			-9501
FC04-67-010C	1	(REFER TO THE CHART IN THE ILLUSTRATION)			-9501
FC07-67-010C	1	(REFER TO THE CHART IN THE ILLUSTRATION)			-9501
FC09-67-010C	1	(REFER TO THE CHART IN THE ILLUSTRATION)			-9501
FC18-67-010C	1	(REFER TO THE CHART IN THE ILLUSTRATION)			-9501
FC33-67-010C	1	(REFER TO THE CHART IN THE ILLUSTRATION)			-9501
FC47-67-010C	1	(REFER TO THE CHART IN THE ILLUSTRATION)			-9501
FC66-67-010D AN(FC66-67-010E)	1				-9C01
FC67-67-010D AN(FC67-67-010E)	1				-9C01
FC04-67-010D	1	(REFER TO THE CHART IN THE ILLUSTRATION)			9501-9701
FC09-67-010D	1	(REFER TO THE CHART IN THE ILLUSTRATION)			9501-9701
FC33-67-010D	1	(REFER TO THE CHART IN THE ILLUSTRATION)			9501-9701
FC47-67-010D	1	(REFER TO THE CHART IN THE ILLUSTRATION)			9501-9701
FC01-67-010D A (FC01-67-010E)	1				9501-9901
FC02-67-010D A (FC02-67-010E)	1				9501-9901
FC07-67-010D A (FC07-67-010E)	1				9501-9901
FC18-67-010D A (FC18-67-010E)	1				9501-9901
FC04-67-010E A (FC04-67-010F)	1				9701-9901
FC09-67-010E A (FC09-67-010F)	1				9701-9901

9501 FC3MNN-707092
 9701 FC3MNN-709151
 9901 FC3MNN-802200
 9C01 FC3MNN-804800

CAT. AUFA02-06

1992-05

AUFA02

(CONT'D)

4-J 7

FROM-TO

-9822

9822-

1992-05

(THIS ILLUSTRATION CONSISTS OF 2 PAGES)

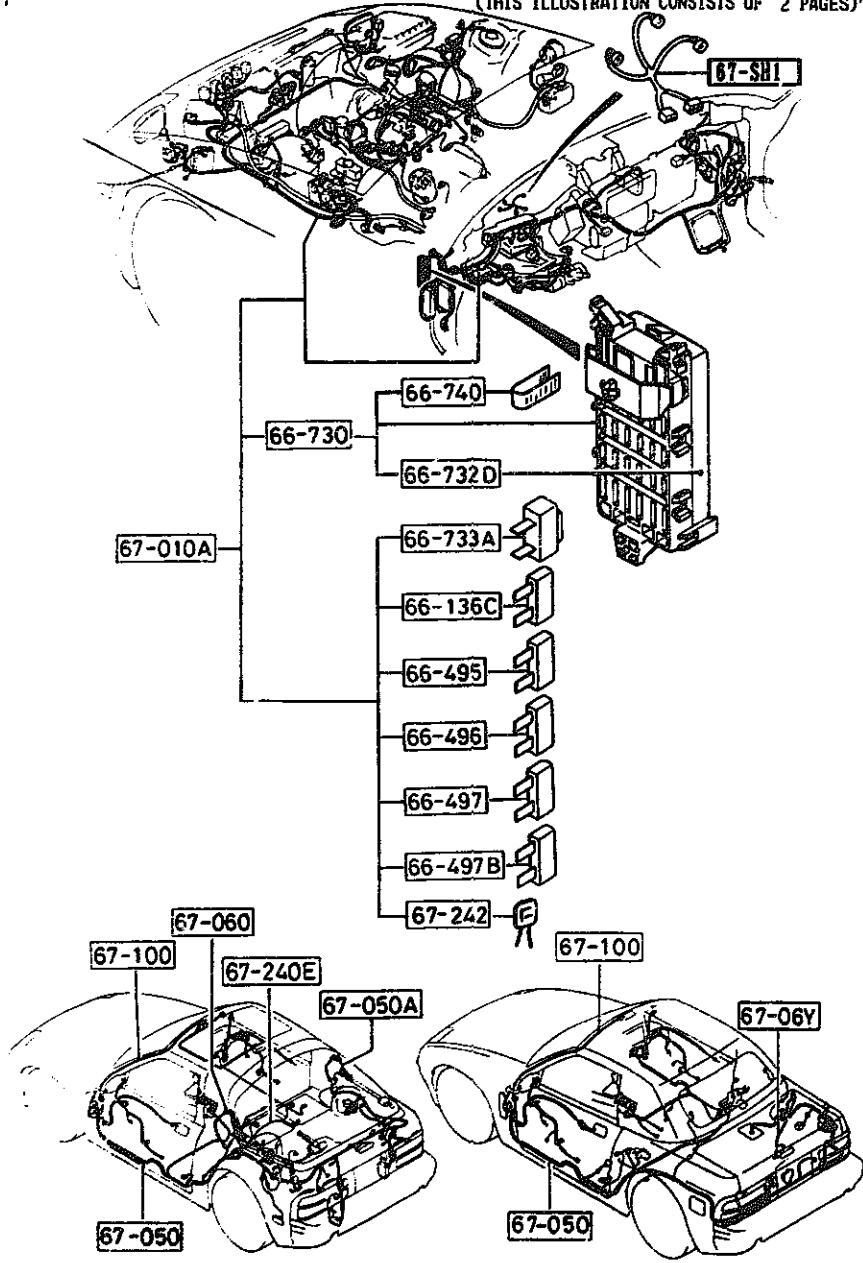

PART NO.	QTY	MODEL/RESTRICTION	MODEL/RESTRICTION	MODEL/RESTRICTION	FROM-TO
CONT'D					
FC33-67-010E A (FC33-67-010F)	1				9701-9901
FC47-67-010E A (FC47-67-010F)	1				9701-9901
FC01-67-010E AN(FC01-67-010F)	1				9901-9801
FC02-67-010E AN(FC02-67-010F)	1				9901-9801
FC04-67-010F AN(FC04-67-010G)	1				9901-9801
FC07-67-010E AN(FC07-67-010F)	1				9901-9801
FC09-67-010F AN(FC09-67-010G)	1				9901-9801
FC18-67-010E AN(FC18-67-010F)	1				9901-9801
FC33-67-010F AN(FC33-67-010G)	1				9901-9801
FC47-67-010F AN(FC47-67-010G)	1				9901-9801
FC01-67-010F	1	(REFER TO THE CHART IN THE ILLUSTRATION)			9801-
FC02-67-010F	1	(REFER TO THE CHART IN THE ILLUSTRATION)			9801-
FC04-67-010G	1	(REFER TO THE CHART IN THE ILLUSTRATION)			9801-
FC07-67-010F	1	(REFER TO THE CHART IN THE ILLUSTRATION)			9801-
FC09-67-010G	1	(REFER TO THE CHART IN THE ILLUSTRATION)			9801-
FC18-67-010F	1	(REFER TO THE CHART IN THE ILLUSTRATION)			9801-
FC33-67-010G	1	(REFER TO THE CHART IN THE ILLUSTRATION)			9801-
FC47-67-010G	1	(REFER TO THE CHART IN THE ILLUSTRATION)			9801-
FC66-67-010E	1	(REFER TO THE CHART IN THE ILLUSTRATION)			9C01-
FC67-67-010E	1	(REFER TO THE CHART IN THE ILLUSTRATION)			9C01-
9701	FC3MM-709151				
9901	FC3MM-802200				
9801	FC3MM-804224				
9C01	FC3MM-804800				

(THIS ILLUSTRATION CONSISTS OF 2 PAGES)

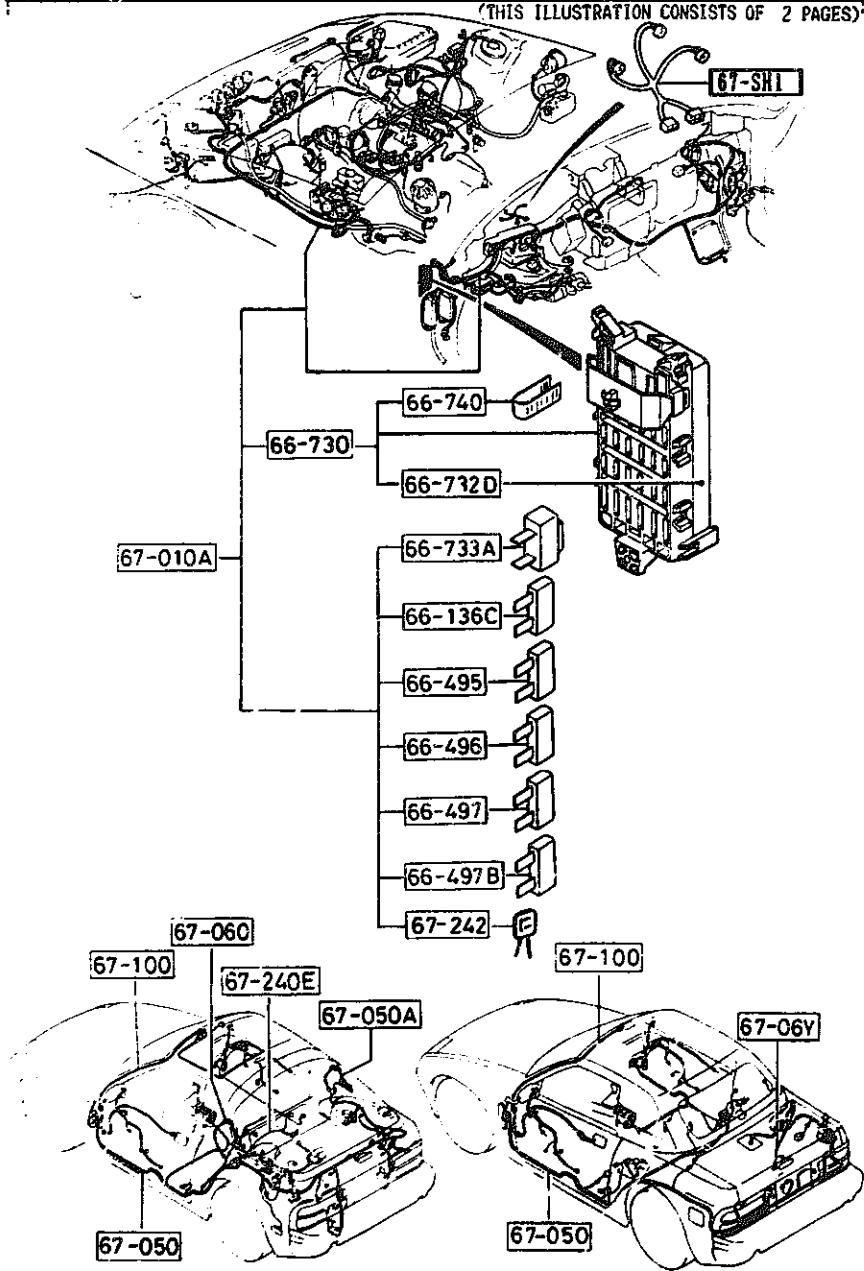

PART NO.	QTY	MODEL/RESTRICTION	MODEL/RESTRICTION	MODEL/RESTRICTION	FROM-TO
CONT'D					
67-050		HARNESS, REAR			
FC66-67-050B	1	((CONVERTIBLE))<W/AIR BAG)			
FC01-67-050D A (FC01-67-050F)	1				-9501
FC04-67-050D A (FC04-67-050F)	1				-9501
FC18-67-050D A (FC18-67-050F)	1				-9501
FC33-67-050D A (FC33-67-050E)	1				-9501
FC01-67-050F	1	((CPE))<W/O A.A. SUSP)<W/O A.LOCK BRAKE)			9501-
FC04-67-050F	1	((CPE))<A.A. SUSP)			9501-
FC18-67-050F	1	((CPE))<W/O A.A. SUSP)<A.LOCK BRAKE)			9501-
FC33-67-050E	1	((CONVERTIBLE))<W/O AIR BAG)			9501-
67-050A		HARNESS NO.1, REAR			
FB02-67-060B	1	(CPE)			
67-06Y		HARNESS NO.3, REAR			
F055-67-06YA A (F055-67-06YB)	1				-9324
F055-67-06YB	1	(CONVERTIBLE)			9324-
67-060		HARNESS NO.2, REAR			
FB01-67-060B	1	(CPE)			
67-100		HARNESS, INT. LAMP			
FC01-67-100C	1	((CPE))<W/O SUN-RF)			
FC03-67-100C	1	((CPE))<SUNROOF)			
FC33-67-100	1	(CONVERTIBLE)			
67-240E		WIRING, STORAGE			
FB01-67-240A	1	GTU, GTUS, GXL, TURBO, (W/STORAGE BOX) (CPE)			

9324 FC33-705162
9501 FC33-707092

6700 WIRING HARNESSSES(FRONT & REAR)

(1/2)

6700 -5 * WIRING HARNESSSES(FRONT & REAR)

(THIS ILLUSTRATION CONSISTS OF 2 PAGES)

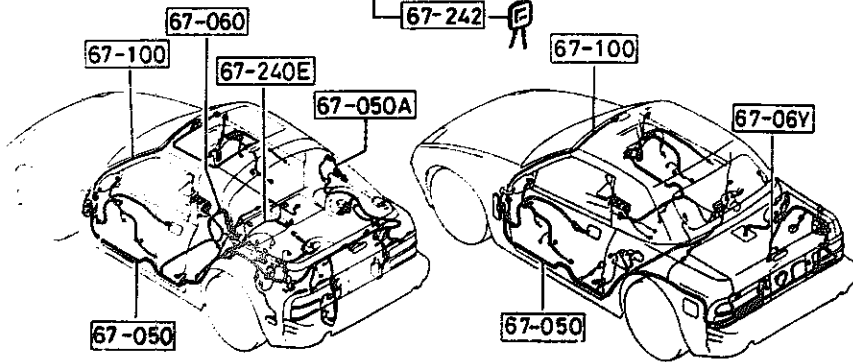
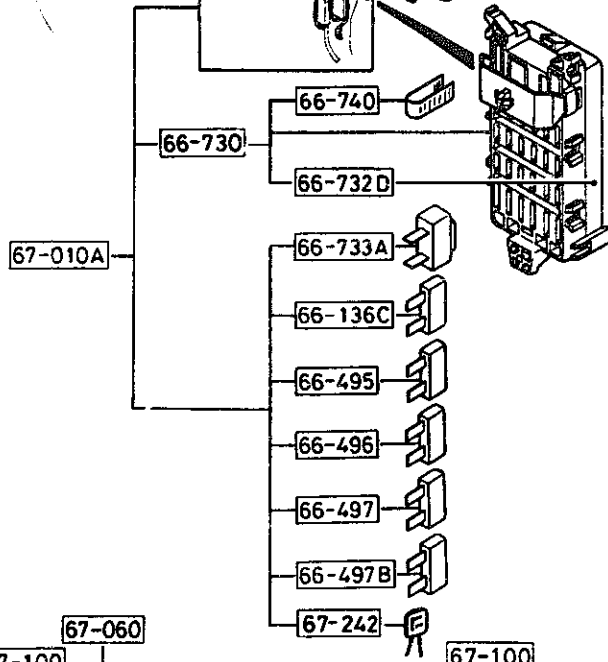
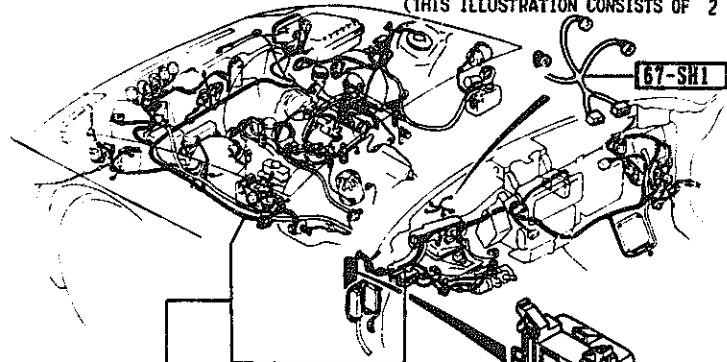

PART NO.	QTY	MODEL/RESTRICTION	MODEL/RESTRICTION	MODEL/RESTRICTION	FROM-TO
67-242		RECTIFIER			
8871-67-242	1	(W/D RUNNING LAMP) (CONVERTIBLE)			

FROM-TO

-0401

0401-

-0401

0401-

1992-05

AUFA02

(CONT'D)

CAT. AUFA02-06

1992-05

4-M 7

SECTION NAME INDEX (BODY) 2/2

LO.NO	SEC.NO	SECTION NAME	LO.NO	SEC.NO	SECTION NAME	LO.NO	SEC.NO	SECTION NAME
4-C03	6100	HEATER	4-E08	6703	WIRING HARNESSSES(DOOR,FLOOR/CEILING)			
4-E03	6110	HEATER UNIT COMPONENTS	4-G08	6704	WIRING HARNESS CLAMPS			
4-F03	6115	HEATER CONTRCLS COMPONENTS	4-J08	6720	WINDSHIELD WASHER (1.5L & 2.5L)			
4-G03	6120	HEATER BLOWER COMPONENTS	4-L08	6720 A	WINDSHIELD WASHER (5.7L)			
4-I03	6130	AIR CONDITIONER	4-N08	6730	WINDSHIELD WIPERS			
4-J03	6230	LIFT GATE MECHANISMS (COUPE)	4-C09	6740	WIPER MOTOR COMPONENTS(FRONT)			
4-M03	6300	WINDOW GLASSES (COUPE)	4-D09	6750	WINDOW WIPER & WASHER (REAR)			
4-N03	6300A	WINDOW GLASSES (CONVERTIBLE)	4-G09	6760	WINDOW WIPER MOTOR COMPONENTS (REAR)			
4-C04	6330	SUNROOF (COUPE)	4-H09	6800	CEILING TRIMS (COUPE)			
4-G04	6330A	SUNROOF (CONVERTIBLE)	4-J09	6800A	CEILING TRIMS (CONVERTIBLE)			
4-M04	6600	SWITCHES & RELAYS (ENGINE)	4-K09	6810	ROLLEBAR (CONVERTIBLE)			
4-G05	6610	DASHBOARD SWITCHES	4-N09	6820	PILLAR TRIMS (COUPE)			
4-H05	6611	COMBINATION SWITCH	4-F10	6820A	PILLAR TRIMS (CONVERTIBLE)			
4-I05	6612	CLUSTER SWITCH	4-G10	6840	TRIMS & SCUFF PLATES (COUPE)			
4-L05	6615	POWER WINDOW SWITCHES	4-L10	6840A	TRIMS & SCUFF PLATES (CONVERTIBLE)			
4-M05	6630	RELAYS & UNIT (BODY)	4-N10	6845	STRAGE BOX (COUPE)			
4-D06	6635	DOOR SWITCH & HORNS			(GXL,TURBO)			
4-E06	6640	AUTO CRUISE CONTROL SYSTEM	4-D11	6860	FLOOR MATS & PADS (COUPE)			
4-F06	6680	AUDIO SYSTEMS (RADIO & TAPE DECK) (COUPE)	4-K11	6860A	FLOOR MATS & PADS (CONVERTIBLE)			
4-K06	6680 A	AUDIO SYSTEMS (RADIO & TAPE DECK) (CONVERTIBLE)	4-C12	6870	SERVICE TOOLS			
4-M06	6682	AUDIO SYSTEMS (ANTENNA & SPEAKER) (COUPE)	4-D12	6900	VISORS,ASSIST HANDLES & MIRRORS (COUPE)			
4-D07	6682 A	AUDIO SYSTEMS (ANTENNA & SPEAKER) (CONVERTIBLE)	4-H12	6900A	VISORS,ASSIST HANDLES & MIRRORS (CONVERTIBLE)			
4-G07	6684	AUDIO SYSTEMS(NOISE SUPPRESSOR & EARTH CORD)	4-K12	6930	CAUTION PLATES & LABELS			
4-H07	6700	WIRING HARNESSSES(FRONT & REAR)	4-N12	7250	QUARTER WINDOW & TRIMS			
4-N07	6701	WIRING HARNESSSES(ENGINE & TRANSMISSION)	4-E13	7800	SPOILERS & RELATED PARTS			
4-D08	6702	WIRING HARNESSSES(DASHBOARD)			ACCESSORIES			

FROM-TO

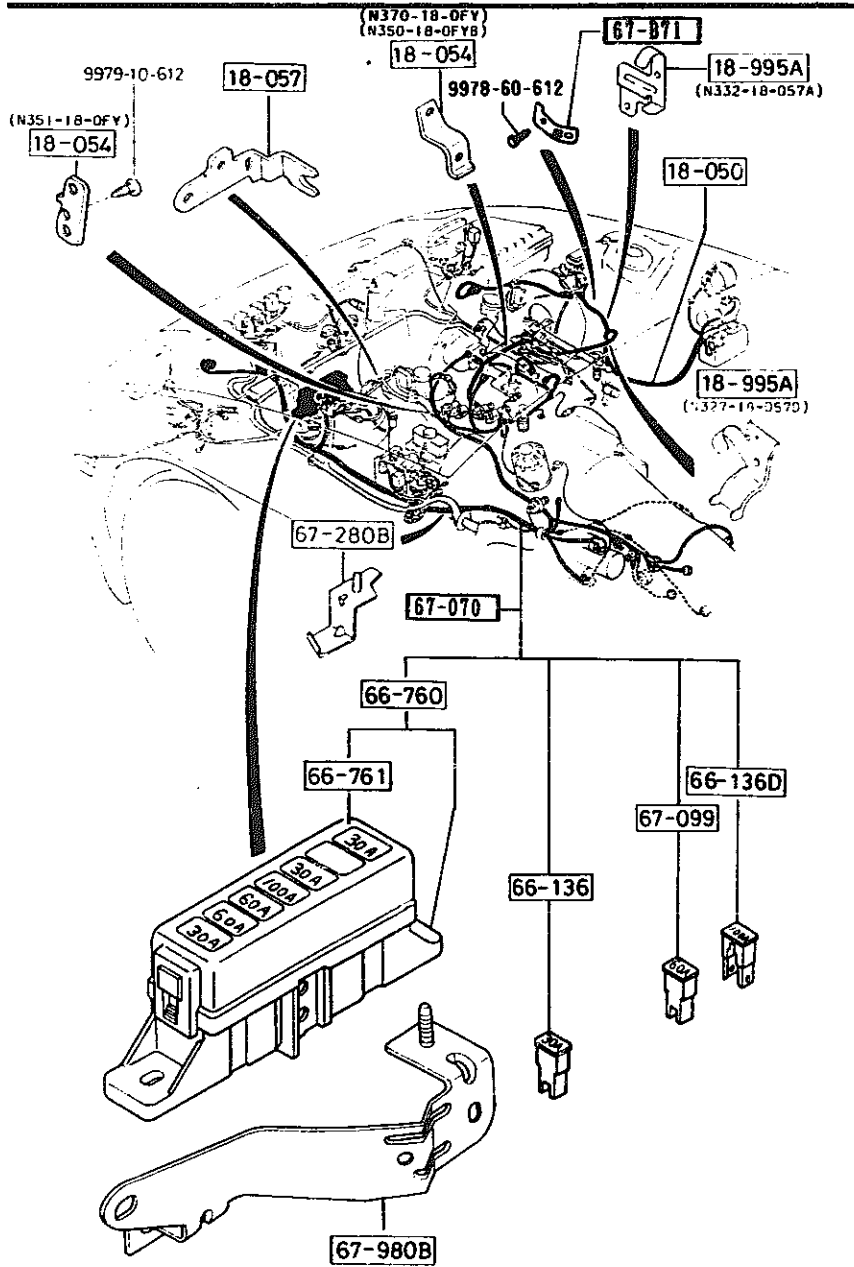

PART NO.	QTY	MODEL/RESTRICTION	MODEL/RESTRICTION	MODEL/RESTRICTION	FROM-TO
66-761		COVER,MAIN FUSE BLOK			
FC01-66-762	1	(W/O AIR BAG)			
FC66-66-762A	1	(W/AIR BAG)			
67-871		BRACKET,HARNESS			
FC66-67-871	1	(W/AIR BAG)			
67-070		HARNESS,ENGINE			
FC66-67-070A	1	((MT))>(W/O A.LOCK BR AKE)>(W/AIR BAG)			
FC67-67-070A	1	((AT))>(W/AIR BAG)			
FC01-67-070C A (FC01-67-070D)	1				-9501
FC07-67-070C A (FC07-67-070D)	1				-9501
FC17-67-070D A (FC17-67-070E)	1				-9501
FC01-67-070D AN(FC01-67-070E)	1				9501-9801
FC07-67-070D AN(FC07-67-070E)	1				9501-9801
FC17-67-070E AN(FC17-67-070F)	1				9501-9801
FC01-67-070E	1	((MT))>(W/O A.LOCK BR AKE)>(W/J AIR BAG)			9801-
FC07-67-070E	1	((AT))>(W/O AIR BAG)			9801-
FC17-67-070F	1	((MT))>(A.LOCK BRAKE) >(W/O AIR BAG)			9801-
67-099		LINK,FUSIBLE			
FB01-67-099	2	60A			
67-280B		BRACKET,BATT. CABLE			
FB01-67-280B A (FB01-67-280C)	1				-9501
FB01-67-280C	1				9501-
67-980B		BRACKET,MAIN FUSE CA SE			
FB01-67-980E	1				
9501 FC3***-707092					
9801 FC3***-804224					

1992-05

AUFA02

CAT. AUFA02-06

1992-05

FROM-TO

6702 WIRING HARNESSSES(DASHBOARD)

6702 -1 W WIRING HARNESSSES(DASHBOARD)

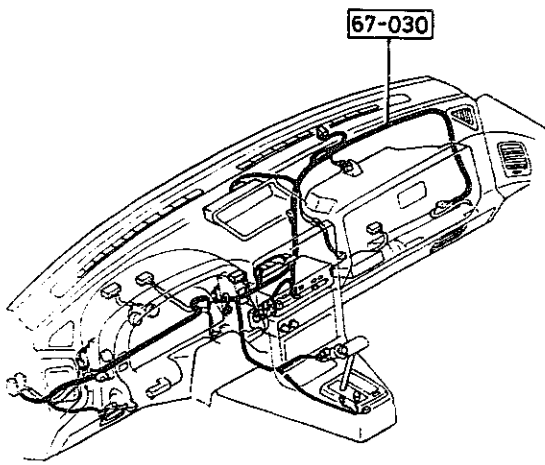

PART NO.	QTY	MODEL/RESTRICTION	MODEL/RESTRICTION	MODEL/RESTRICTION	FROM-TO
67-030		HARNES, INSTRUMENT			
FC66-67-030B	1	((CONVERTIBLE)>(MT)>(W/AIR BAG)			
FC67-67-030B	1	((CONVERTIBLE)>(AT)>(W/AIR BAG)			
FC01-67-030C	1	((CPE)>(MT)			-9501
FC07-67-030C	1	((CPE)>(AT)			-9501
FC33-67-030D	1	((CONVERTIBLE)>(MT)>(W/O AIR BAG)			-9501
FC47-67-030C	1	((CONVERTIBLE)>(AT)>(W/O AIR BAG)			-9501
FC01-67-030D	1	((CPE)>(MT)			9501-
FC07-67-030D	1	((CPE)>(AT)			9501-
FC33-67-030E	1	((CONVERTIBLE)>(MT)>(W/O AIR BAG)			9501-
FC47-67-030D	1	((CONVERTIBLE)>(AT)>(W/O AIR BAG)			9501-

9501 FC33-707092

1992-05

AUFA02

CAT. AUFA02-06

1992-05

4-D 8

6703 WIRING HARNESSES(DOOR,FLOOR/CEILING)

6703 -1 WIRING HARNESSES(DOOR,FLOOR/CEILING)

FROM-TO

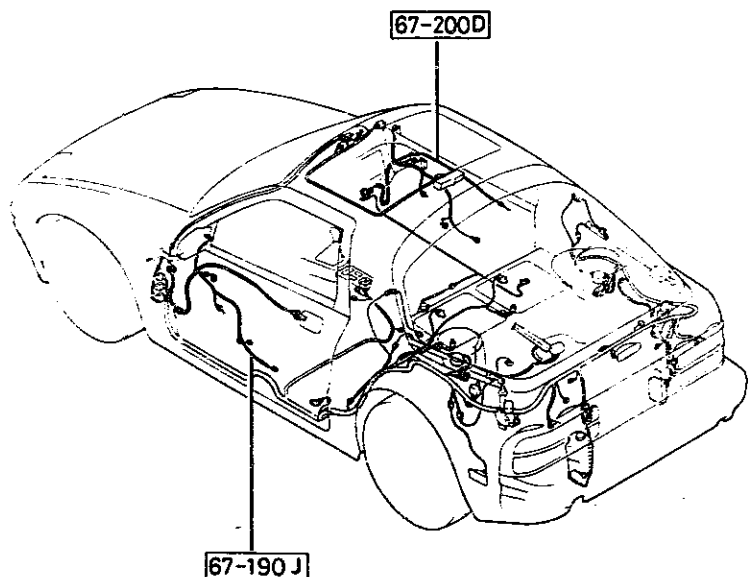

PART NO.	QTY	MODEL/RESTRICTION	MODEL/RESTRICTION	MODEL/RESTRICTION	FROM-TO
<div style="border: 1px solid black; display: inline-block; padding: 2px;">67-190J</div>					
HARNES, DOOR-DRIVER SIDE					
FC01-67-190D AN(FC01-67-190E)	1				-9324
FC02-67-190D AN(FC02-67-190E)	1				-9324
FC04-67-190D AN(FC04-67-190E)	1				-9324
FC33-67-190D AN(FC33-67-190E)	1				-9324
FC01-67-190E AN(FC01-67-190F)	1				9324-9501
FC02-67-190E AN(FC02-67-190F)	1				9324-9501
FC04-67-190E AN(FC04-67-190F)	1				9324-9501
FC33-67-190E AN(FC33-67-190F)	1				9324-9501
FC01-67-190F	1	((CPE))>(W/D TURBO)>(NOR.DIFF)			9501-
FC02-67-190F	1	((CPE))>(L.S.DIFF)			9501-
FC04-67-190F	1	((CPE))>(TURBO)			9501-
FC33-67-190F	1	(CONVERTIBLE)			9501-
<div style="border: 1px solid black; display: inline-block; padding: 2px;">67-200D</div>					
HARNES, DOOR-PASSENGER SIDE					
FC01-67-200D AN(FC01-67-200E)	1				-9324
FC02-67-200D AN(FC02-67-200E)	1				-9324
FC04-67-200D AN(FC04-67-200E)	1				-9324
FC33-67-200D AN(FC33-67-200E)	1				-9324
FC01-67-200E AN(FC01-67-200F)	1				9324-9501
FC02-67-200E AN(FC02-67-200F)	1				9324-9501
FC04-67-200E AN(FC04-67-200F)	1				9324-9501
FC33-67-200E AN(FC33-67-200F)	1				9324-9501
FC01-67-200F	1	((CPE))>(W/D TURBO)>(NOR.DIFF)			9501-
FC02-67-200F	1	((CPE))>(L.S.DIFF)			9501-
FC04-67-200F	1	((CPE))>(TURBO)			9501-
9324 FC3MM-705162 9501 FC3MM-707092					

1992-05

AUFA02

CAT. AUFA02-06

1992-05

6703 WIRING HARNESES(DOOR,FLOOR/CEILING)

6703 -2 * WIRING HARNESES(DOOR,FLOOR/CEILING)

FROM-TO

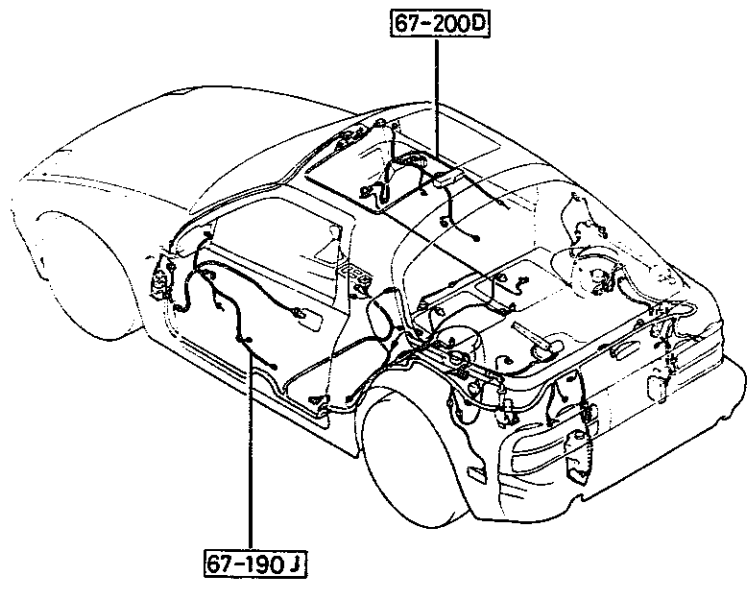

PART NO.	QTY	MODEL/RESTRICTION	MODEL/RESTRICTION	MODEL/RESTRICTION	FROM-TO
CONT'D FC33-67-200F	1	(CONVERTIBLE)			9501-
9501 FC3MM-707092					

1992-05

AUFA02

CAT. AUFA02-06

1992-05

4-E-8

(THIS ILLUSTRATION CONSISTS OF 2 PAGES)

(THIS ILLUSTRATION CONSISTS OF 2 PAGES)

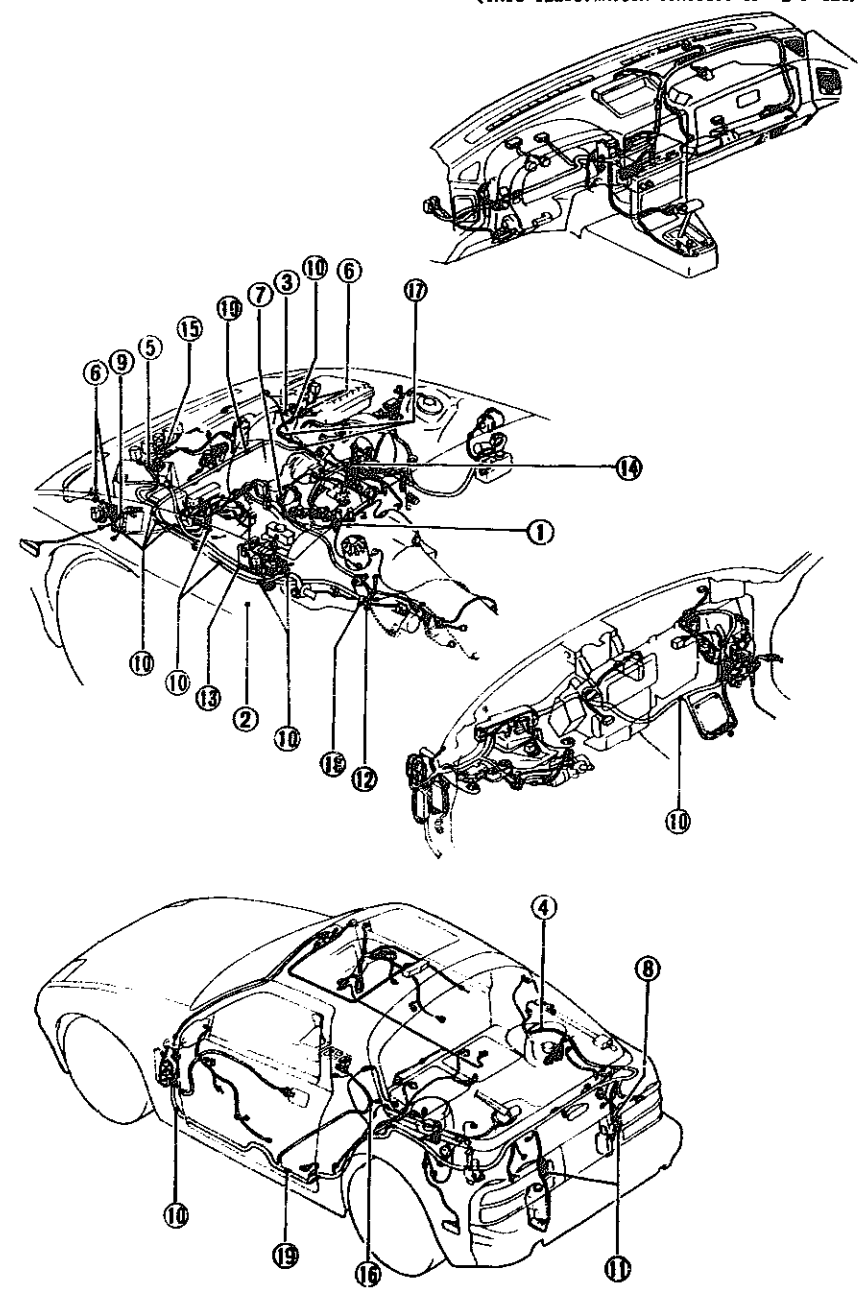

① 18-141E (N319-18-14Y)	② 45-961B 	③ 66-941A 	④ 66-941C 	⑤ 67-012A
⑥ 67-014A 	⑦ 67-019 	⑧ 67-031B 	⑨ 67-051E (U842-67-051)	⑩ 67-051E (#029-67-051A)
⑪ 67-052J 	⑫ 67-072A (FC31-67-072A)	⑬ 67-073 	⑭ 67-073B 	⑮ 67-254 (S113-67-254A)
⑯ 67-293 	⑰ 18-141E (N350-18-14Y)	⑱ 67-254 (FC04-SI-67A)	⑲ 67-072A (#029-67-072A)	⑳ 2C-451

6704 WIRING HARNESS CLAMPS

(1/2)

(THIS ILLUSTRATION CONSISTS OF 2 PAGES)

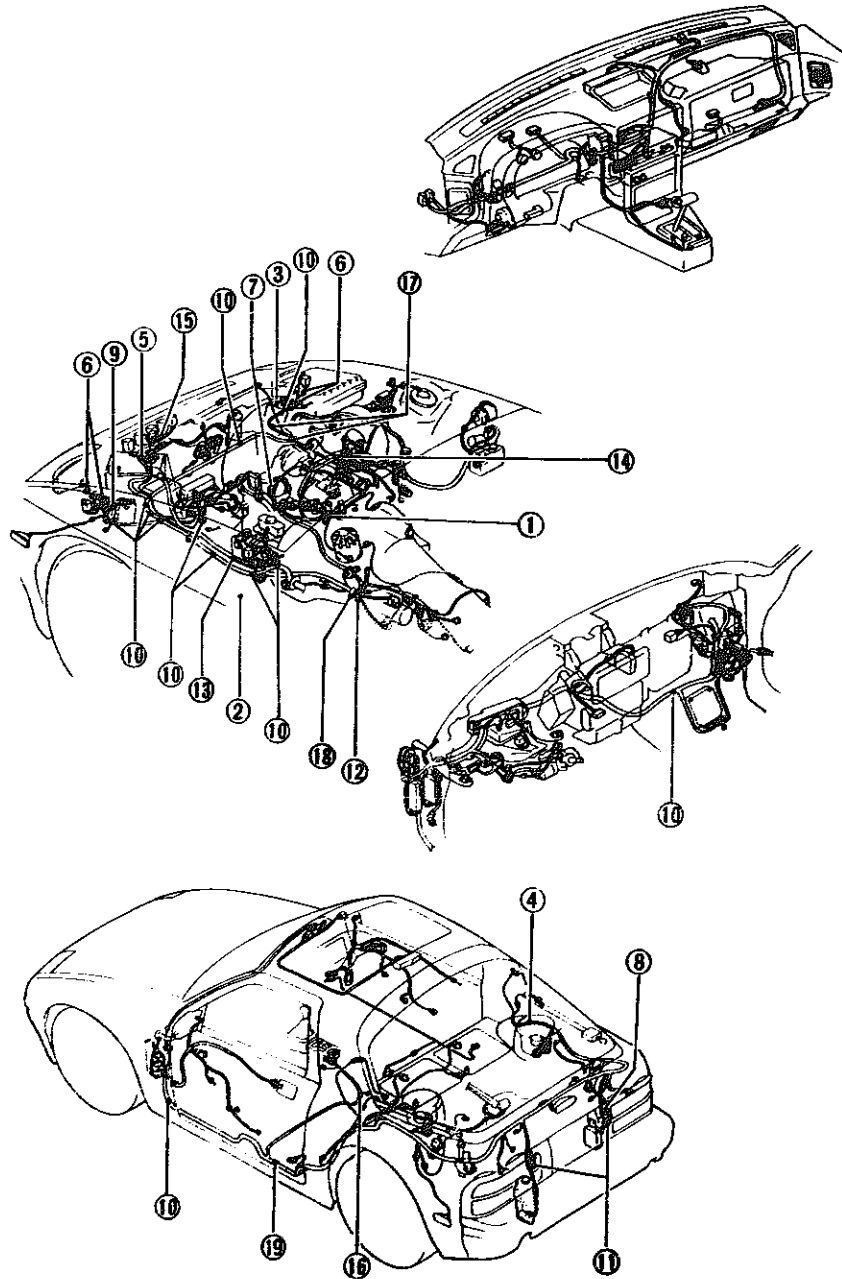

6704 -1 WIRING HARNESS CLAMPS

PART NO.	QTY	MODEL/RESTRICTION	MODEL/RESTRICTION	MODEL/RESTRICTION	FROM TO
18-141E		SUPPORTER, CORD			
N319-18-14Y	1	(TURBO)			
N350-18-14Y	1	(W/D TURBO)			
20-451		CLIP			
MB612-20-468	1	(CONVERTIBLE)			
45-961B		CAP			
H002-45-961	1				
66-941A		CLIP			
GB08-66-941	1				
66-941C		CLIP			
UB42-66-971	1	(CPE)			
67-012A		CLIP			
FB01-67-012	1				
67-014A		CLIP			
FB01-67-014	4				
67-019		CLIP			
FB02-67-019A	1				
67-031B		CLIP			
UB42-67-031	1				
67-051E		CLIP			
W029-67-051A	10	(CPE) (CONVERTIBLE)			
UB42-67-051 A (S113-67-254A)	1				-9301
W029-67-051A (UB42-67-031)	8	(CPE)			-9301
W029-67-051A	14	(CONVERTIBLE)			9301-
67-052J		CLIP			
B001-67-051	2	(CPE)			
67-072A		CLIP			
9301 FC3MNN-704194					

AUFA02

(CONT'D)

CAT. AUFA02-06

1992-05

4-H 8

(THIS ILLUSTRATION CONSISTS OF 2 PAGES)

① 18-141E (N319-18-14Y)	② 45-961B 	③ 66-941A 	④ 66-941C 	⑤ 67-012A
⑥ 67-014A 	⑦ 67-019 	⑧ 67-031B 	⑨ 67-051E (UB42-67-051)	⑩ 67-051E (8029-67-051A)
⑪ 67-052J 	⑫ 67-072A (FC01-67-072A) 	⑬ 67-073 	⑭ 67-073B 	⑮ 67-254 (S113-67-254A)
⑯ 67-293 	⑰ 18-141E (N350-18-14Y) 	⑱ 67-254 (FC04-51-674) 	⑲ 67-072A (HE20-67-072) 	⑳ 20-451

PART NO.	QTY	MODEL/RESTRICTION	MODEL/RESTRICTION	MODEL/RESTRICTION	FROM-TO
CONT'D					
FC01-67-072A	1				
*HE20-67-072	1				
67-073		CLIP			
FB01-67-073A	1				
FB01-67-073A	1				-9801
67-073B		CLIP			
H261-67-073	1				
67-254		CLIP, CABLE			
FC04-51-674	2	((CONVERTIBLE))>(W/O AIR BAG)			
S113-67-254A	2	((CONVERTIBLE))>(W/O AIR BAG) (CPE)			
67-293		CLIP, CABLE			
S083-67-253	1				
9801 FC3***-800894					

FROM-TO

-9501

-9501

9501-

9501-

-9501

6720 WINDSHIELD WASHER
(1.5L & 2.5L)

6720 -1 WINDSHIELD WASHER
(1.5L & 2.5L)

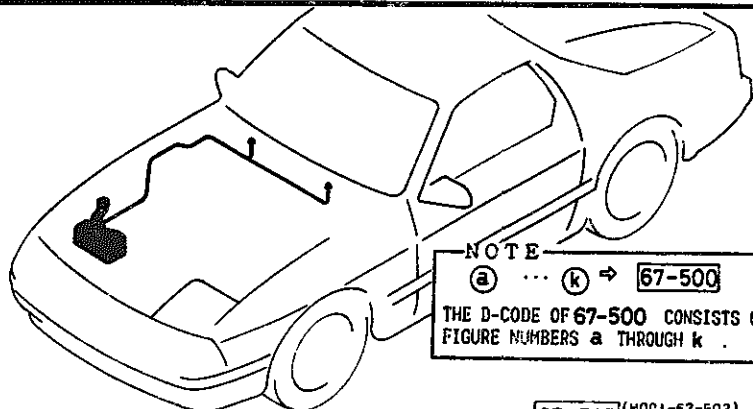

NOTE
 (a) ... (k) → 67-500
 THE D-CODE OF 67-500 CONSISTS OF
 FIGURE NUMBERS a THROUGH k

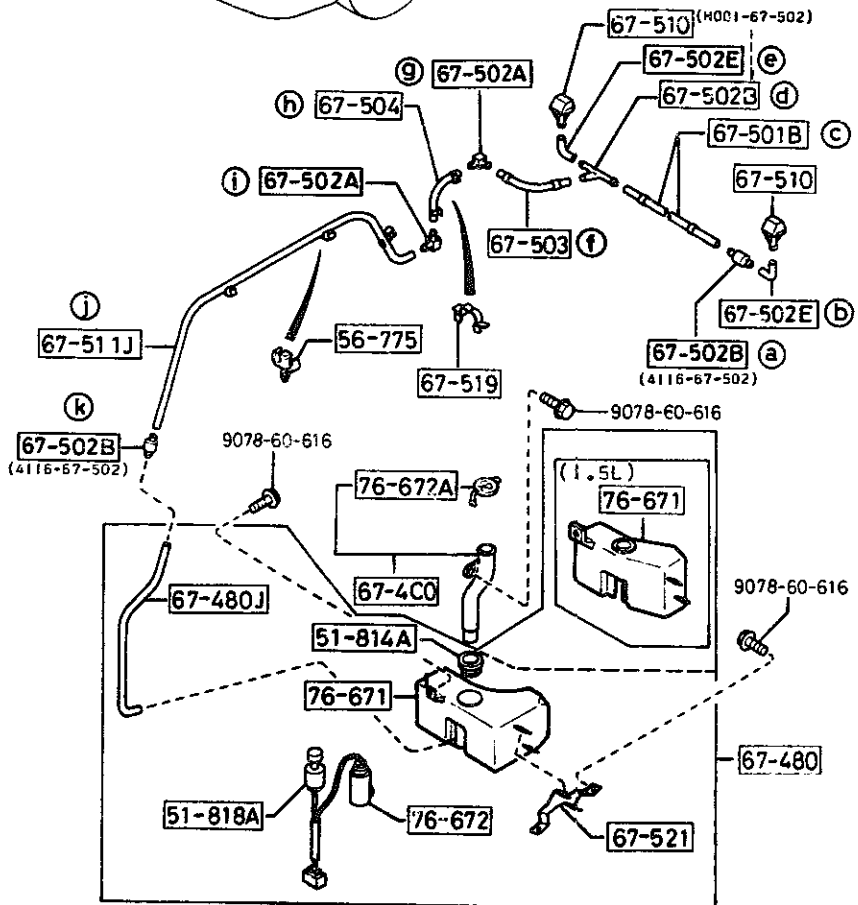

PART NO.	QTY	MODEL/RESTRICTION	MODEL/RESTRICTION	MODEL/RESTRICTION	FROM-TO
51-814A		GROMMET, WASHER TANK			
FB01-51-816	1				
51-818A		SWITCH, LEVEL-WASHER TANK			
FB01-67-488A	1				
56-775		CLIP, WIRE-BONNET			
H260-67-519A	3				
67-4C0		PIPE, FILLER-F. WASHER TANK			
FB01-67-4C0B	1				
67-480		TANK, WASHER-FRONT			
FB01-67-4T0D	1	USA, (W/WASHER TANK 1.5L)			
FB03-67-4T0D	1	NON USA,			
67-480J		PIPE, VINYL			
FB04-67-503A	1				
67-500		PIPE			
FB01-67-500C	1				
67-501B		HOSE 'A', WASHER			
FB01-67-501C	1				
67-502A		JOINT, HOSE			
H261-67-502	2				
67-502B		JOINT, HOSE			
H001-67-502	1				
4116-67-502	2				
67-502E		JOINT, ELBOW-W. TANK			
S084-67-502	2				
67-503		HOSE 'B', WASHER			
FB01-67-503B	1				
67-504		HOSE 'C', WASHER			

FROM-TO
 -9501
 -9501
 -9501
 -9501
 -9501
 -9501
 -9501
 -9C01
 -9C01
 9501-9701
 9501-9701
 9501-9701
 9501-9701
 9501-9901
 9501-9901
 9501-9901
 9501-9901
 9701-9901
 9701-9901
 1992-05

AUFA02

CAT. AUFA02-06

1992-05

6720 A WINDSHIELD WASHER
(5.7L)

6720 A-1 WINDSHIELD WASHER
(5.7L)

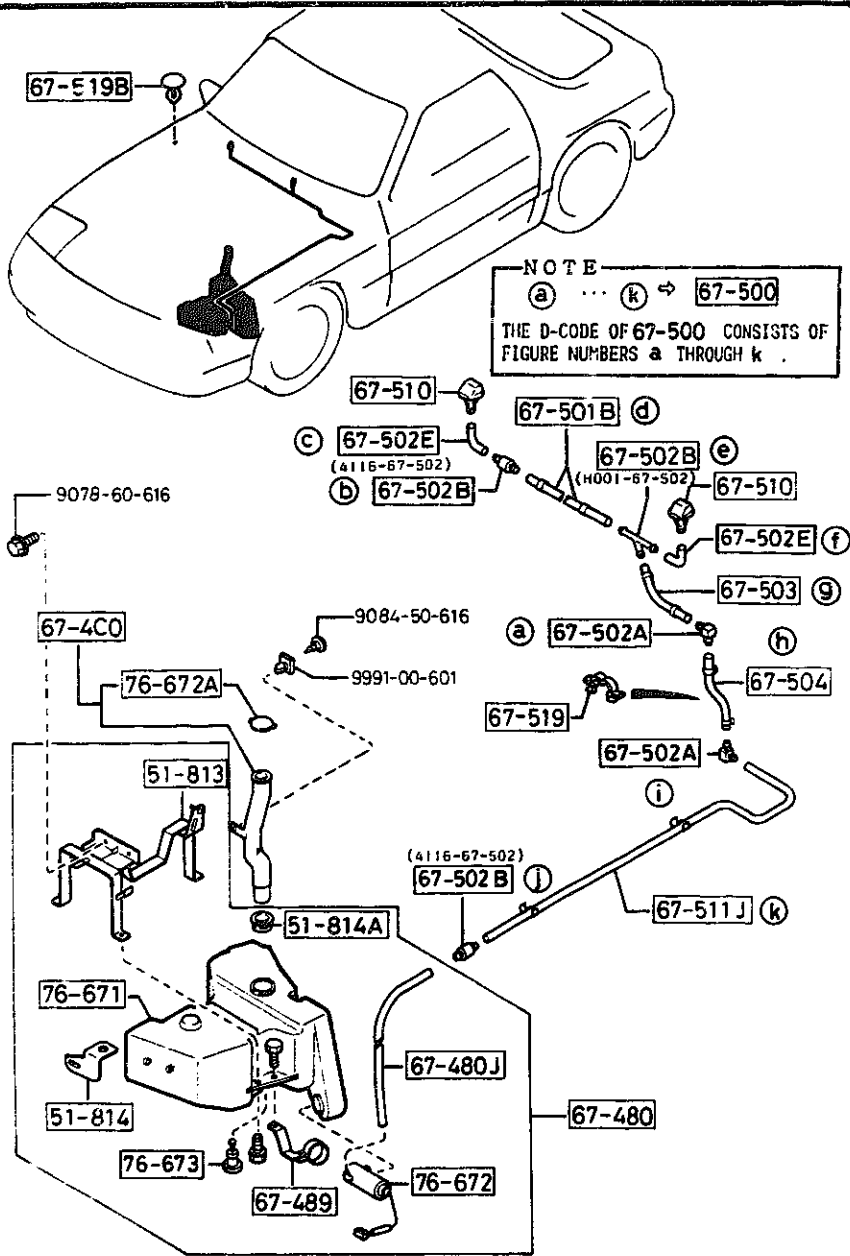

PART NO.	QTY	MODEL/RESTRICTION	MODEL/RESTRICTION	MODEL/RESTRICTION	FROM-TO
51-813		HOLDER 'A'			
FB01-51-814	1				
51-814		HOLDER 'B'			
FB01-51-819	1				
51-814A		GROMMET, WASHER TANK			
FB01-51-816	1				
67-4C0		PIPE, FILLER-F. WASHER TANK			
FB05-67-4C0B	1				
67-480		TANK, WASHER-FRONT			
FB05-67-4T0E	1				
67-480J		PIPE, VINYL			
FB05-67-501B	1				
67-489		HOLDER, PUMP-WASHER			
FB05-67-489	1				
67-500		PIPE			
FB05-67-500C	1				
67-501B		HOSE 'A', WASHER			
FB01-67-501C	1				
67-502A		JOINT, HOSE			
H261-67-502	2				
67-502B		JOINT, HOSE			
H001-67-502	1				
4116-67-502	2				
67-502E		JOINT, ELBOW-W. TANK			
S084-67-502	2				
67-503		HOSE 'B', WASHER			
FB48-67-503A	1				

6720 A WINDSHIELD WASHER
(5.7L)

6720 A-2 * WINDSHIELD WASHER
(5.7L)

FROM-TO

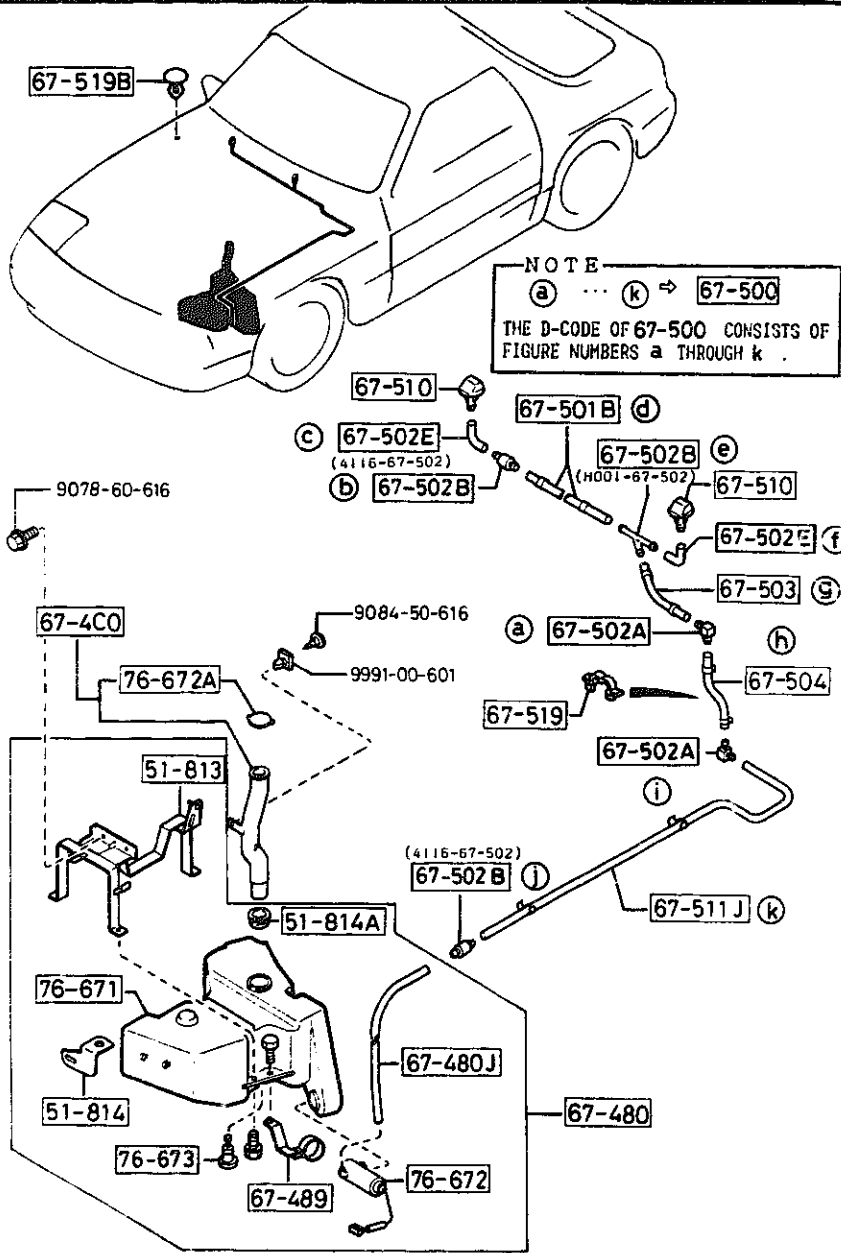

PART NO.	QTY	MODEL/RESTRICTION	MODEL/RESTRICTION	MODEL/RESTRICTION	FROM-TO
67-504		HOSE 'C', WASHER			
FB05-67-504	1				
67-510		NOZZLE, WASHER-F. WIND			
FB01-67-510	2				
67-511J		PIPE, SCREEN WASHER			
FB03-67-503A	1				
67-519		CLIP, PIPE			
FB01-67-519A	3				
67-519B		CLIP			
FB03-67-519	3				
75-671		TANK, WASHER			
FB05-67-481A	1				
76-672		PUMP, WASHER			
FB05-67-482B	1				
76-672A		CAP, TANK			
UB39-51-815	1				
76-673		SWITCH, LEVEL			
FB05-67-488	1				

1992-05

AUFA02

CAT. AUFA02-06

1992-05

FROM TO

-9701
-9701
-9C01
9701-
9701-9C01
9C01-
9C01-

-9601
9601-

-9914
9914-

1992-05

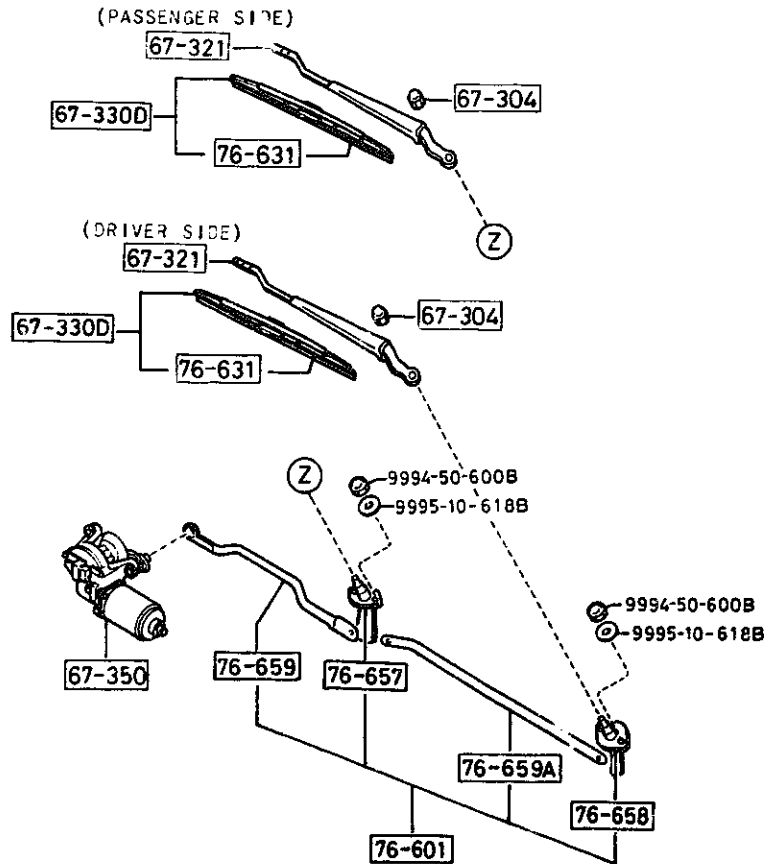
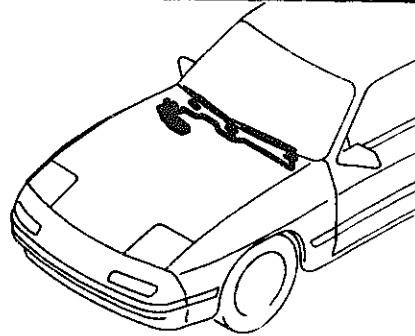

PART NO.	QTY	MODEL/RESTRICTION	MODEL/RESTRICTION	MODEL/RESTRICTION	FROM TO
67-304		NUT, WIPER ARM-FRONT			
FB01-67-304	2				
67-321		ARM, WIPER			
FB01-67-321B	1	(PASSENGER SIDE)			
FB02-67-321A	1	(DRIVER SIDE)			
67-330D		BLADE (L), WIPER-FRONT			
HE76-67-330A (HE76-57-330A)	2				-9A01
HE76-67-330A	2				9A01-
67-350		MOTOR, WIPER			
FB06-67-350	1				
76-601		LINK, WIPER			
FB01-67-360C	1	USA, (MILE/KM)			
FB06-67-360	1	NON USA,			
76-631		RUBBER, BLADE-FRONT			
HE76-67-331A (HE76-67-331A)	2				-9A01
HE76-67-331A	2				9A01-
76-657		SHAFT, DRIVE NO.1			
FB01-67-363	1	USA, (MILE/KM)			
FB06-67-363	1	NON USA,			
76-658		SHAFT, DRIVE NO.2			
FB01-67-364	1	USA, (MILE/KM)			
FB06-67-364	1	NON USA,			
76-659		ARM NO.1, LINK			
FB01-67-361	1				
76-659A		ARM NO.2, LINK			
FB01-67-362	1				

9A01 FC3MM-803554

SECTION NAME INDEX (BODY) 2/2

LD.NO	SEC.NO	SECTION NAME	LD.NO	SEC.NO	SECTION NAME	LD.NO	SEC.NO	SECTION NAME
4-C03	6100	HEATER	4-E08	6703	WIRING HARNESES(DOOR,FLOOR/CEILING)			
4-E03	6110	HEATER UNIT COMPONENTS	4-G08	6704	WIRING HARNESS CLAMPS			
4-F03	6115	HEATER CONTROLS COMPONENTS	4-J08	6720	WINDSHIELD WASHER (1.5L & 2.5L)			
4-G03	6120	HEATER BLOWER COMPONENTS	4-L08	6720 A	WINDSHIELD WASHER (5.7L)			
4-I03	6130	AIR CONDITIONER	4-N08	6730	WINDSHIELD WIPERS			
4-J03	6230	LIFT GATE MECHANISMS (COUPE)	4-C09	6740	WIPER MOTOR COMPONENTS(FRONT)			
4-M03	6300	WINDOW GLASSES (COUPE)	4-D09	6750	WINDOW WIPER & WASHER (REAR)			
4-N03	6300A	WINDOW GLASSES (CONVERTIBLE)	4-G09	6760	WINDOW WIPER MOTOR COMPONENTS (REAR)			
4-C04	6330	SUNROOF (COUPE)	4-H09	6800	CEILING TRIMS (COUPE)			
4-G04	6330A	SUNROOF (CONVERTIBLE)	4-J09	6800A	CEILING TRIMS (CONVERTIBLE)			
4-M04	6600	SWITCHES & RELAYS (ENGINE)	4-K09	6810	ROLLEBAR (CONVERTIBLE)			
4-G05	6610	DASHBOARD SWITCHES	4-N09	6820	PILLAR TRIMS (COUPE)			
4-H05	6611	COMBINATION SWITCH	4-F10	6820A	PILLAR TRIMS (CONVERTIBLE)			
4-I05	6612	CLUSTER SWITCH	4-G10	6840	TRIMS & SCUFF PLATES (COUPE)			
4-L05	6615	POWER WINDOW SWITCHES	4-L10	6840A	TRIMS & SCUFF PLATES (CONVERTIBLE)			
4-M05	6630	RELAYS & UNIT (BODY)	4-N10	6845	STRAGE BOX (COUPE)			
4-D06	6635	DOOR SWITCH & HORNS			(GXL,TURBO)			
4-E06	6640	AUTO CRUISE CONTROL SYSTEM	4-D11	6860	FLOOR MATS & PADS (COUPE)			
4-F06	6680	AUDIO SYSTEMS (RADIO & TAPE DECK) (COUPE)	4-K11	6860A	FLOOR MATS & PADS (CONVERTIBLE)			
4-K06	6680 A	AUDIO SYSTEMS (RADIO & TAPE DECK) (CONVERTIBLE)	4-C12	6870	SERVICE TOOLS			
4-M06	6682	AUDIO SYSTEMS (ANTENNA & SPEAKER) (COUPE)	4-D12	6900	VISORS,ASSIST HANDLES & MIRRORS (COUPE)			
4-D07	6682 A	AUDIO SYSTEMS (ANTENNA & SPEAKER) (CONVERTIBLE)	4-H12	6900A	VISORS,ASSIST HANDLES & MIRRORS (CONVERTIBLE)			
4-G07	6684	AUDIO SYSTEMS(NOISE SUPPRESSOR & EARTH CORD)	4-K12	6930	CAUTION PLATES & LABELS			
4-H07	6700	WIRING HARNESES(FRONT & REAR)	4-N12	7250	QUARTER WINDOW & TRIMS			
4-N07	6701	WIRING HARNESES(ENGINE & T/MISSION)	4-E13	7800	SPOILERS & RELATED PARTS			
4-D08	6702	WIRING HARNESES(DASHBOARD)	4-C14	7900	ACCESSORIES			



6740 WIPER MOTOR COMPONENTS(FRONT)

COMPONENTS OF FB06-67-350

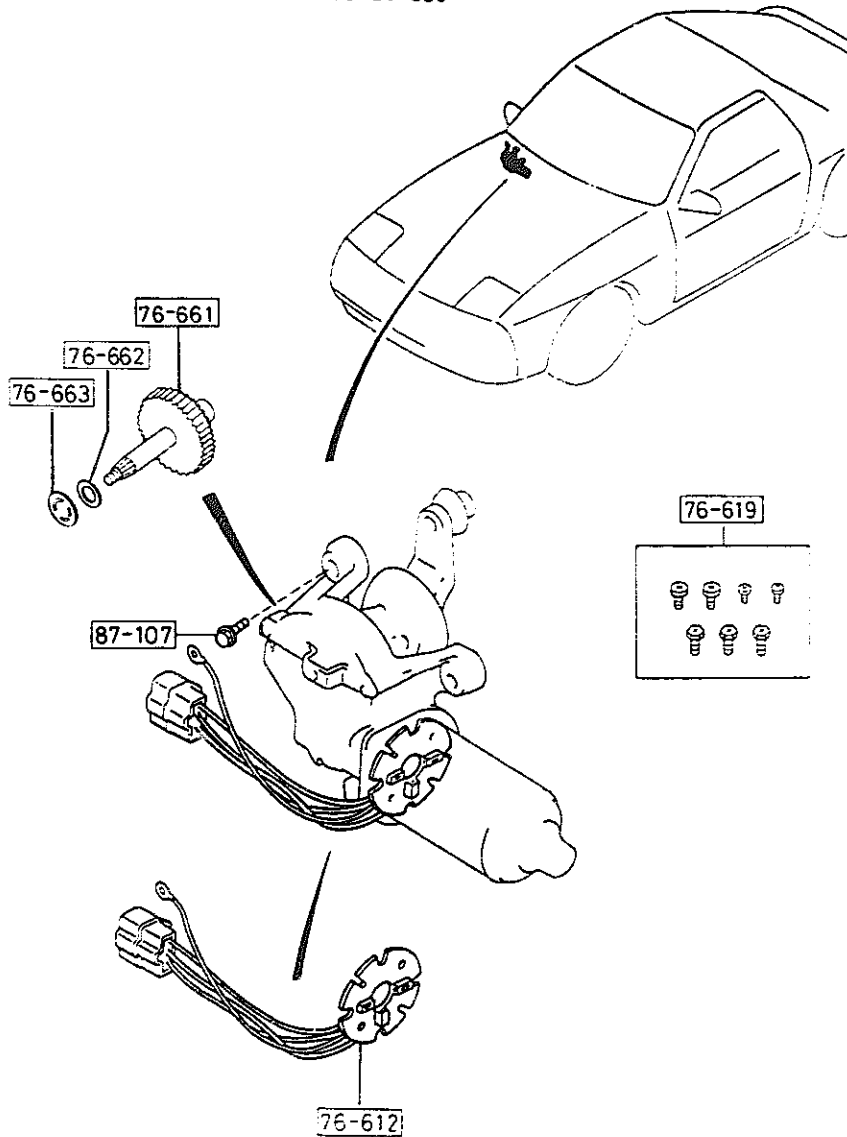

PART NO.	QTY	MODEL/RESTRICTION	MODEL/RESTRICTION	MODEL/RESTRICTION	FROM-TO
76-612		PLATE, HOLDER-BRUSH			
FB05-67-351	1				
76-619		PARTS SET			
H043-76-619A	1				
76-661		GEAR, SHAFT			
GJ83-67-354	1				
76-662		WASHER			
B094-76-662	1				
76-663		WASHER, TOOTHED			
B094-76-663	1				
87-107		SCREW			
B092-76-623	1				

FROM-TO

-9501

-9501

-9501

9501-9801

9501-9801

9501-9801

9801-

9801-

9801-

-9501

9501-

1992-05

AUFA02

CAT. AUFA02-06

1992-05

6750 WINDOW WIPER & WASHER (REAR)

6750 -1 WINDOW WIPER & WASHER (REAR)

FROM-TO
-9501
-9501
-9501
-9501
9501-
9501-
9501-
9501-

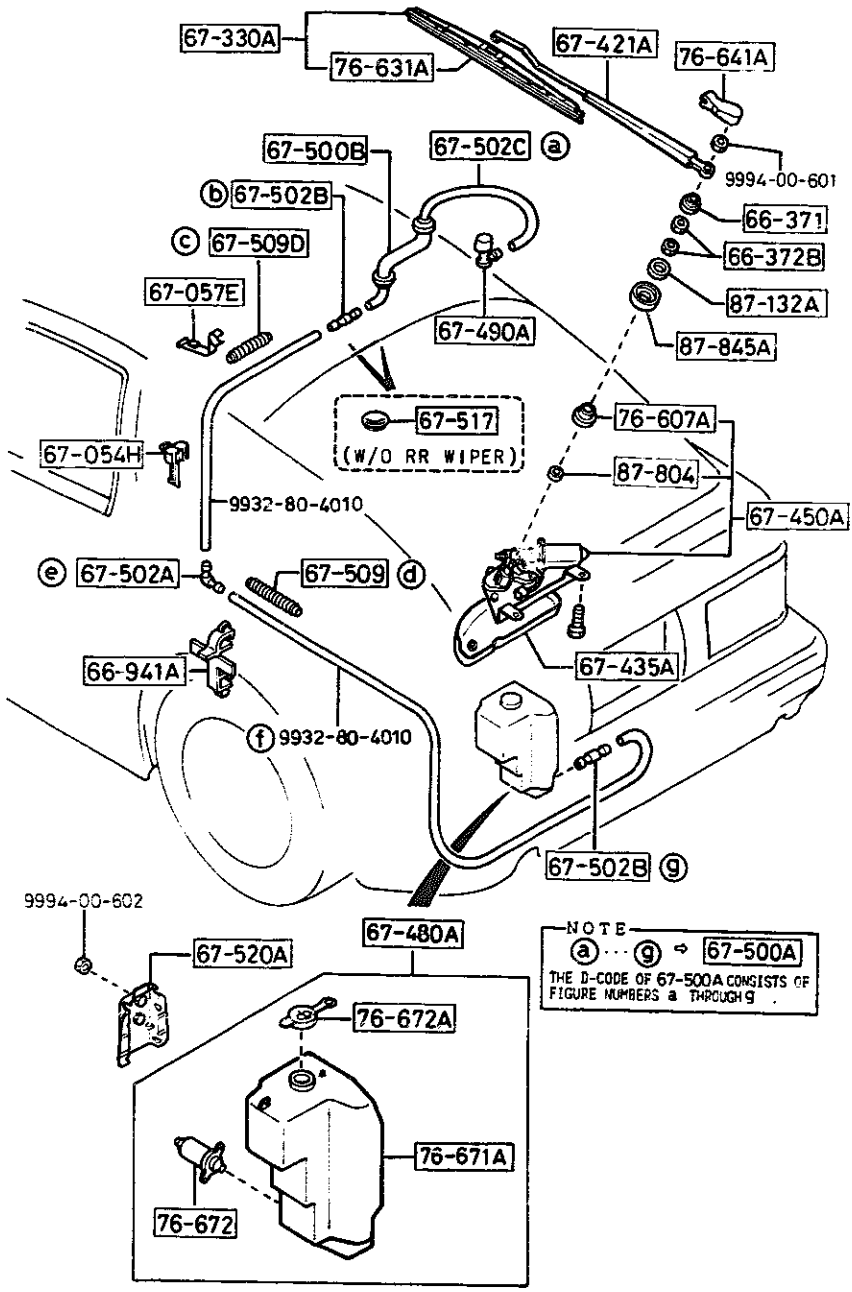

NOTE
a ... g ⇄ 67-500A
THE D-CODE OF 67-500A CONSISTS OF
FIGURE NUMBERS a THROUGH g

PART NO.	QTY	MODEL/RESTRICTION	MODEL/RESTRICTION	MODEL/RESTRICTION	FROM-TO
66-371		CAP, SEAL			
FB02-67-366A	1				
66-372B		NUT			
D001-76-605	2				
66-941A		CLIP			
GB08-66-941	1				
67-054H		CLIP, OPENER CABLE			
FB02-67-056	3				
67-057E		CLIP 'B', PIPE-REAR WASH			
FB02-67-057	2	SHER			
67-330A		BLADE, WIPER-REAR			
FB02-67-330	1				
67-421A		ARM, WIPER			
FC01-67-421	1				
67-435A		COVER, WIPER MOTOR			
FB02-67-458B	1				
67-450A		MOTOR			
FBC2-67-450A	1				
67-480A		TANK, WASHER-REAR			
FB02-67-480A	1				
67-490A		NOZZLE, WASHER-R. WIND			
FB02-67-510	1				
67-500A		PIPE, REAR WASHER-LOW			
FB02-67-500	1	ER			
67-500B		PIPE, REAR WASHER-UPP			
FB04-67-500B	1	ER			
67-502A		JOINT, HOSE			
S013-67-502	1				

FROM-TO
 -9324
 -9324
 -9324
 -9324
 9324-9501
 9324-9501
 9324-9501
 9324-9501
 9501-
 9501-
 9501-
 9501-
 -9324
 -9324
 -9324
 -9324
 9324-9501
 9324-9501
 9324-9501
 9324-9501
 9501-
 9501-
 9501-

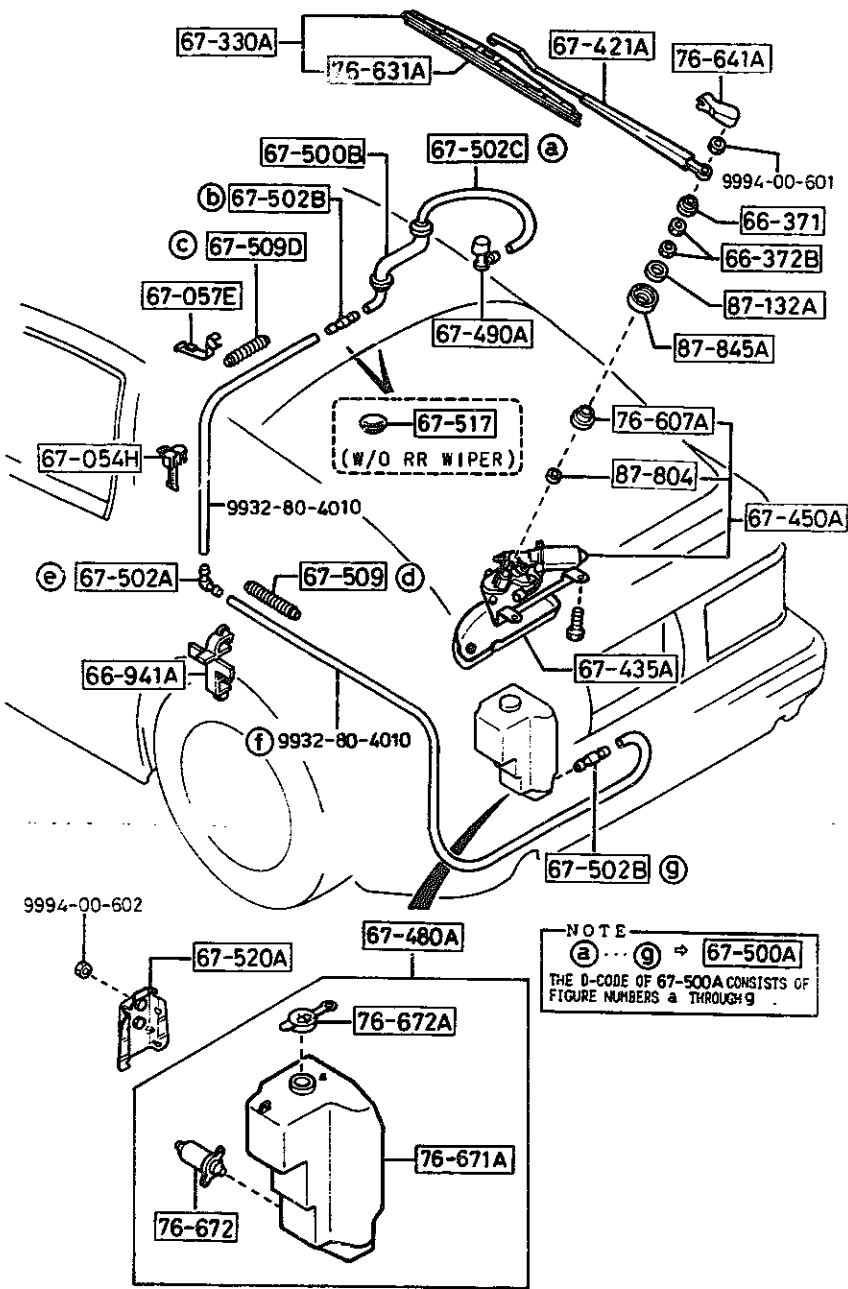

NOTE
 (a) ... (g) → 67-500A
 THE D-CODE OF 67-500A CONSISTS OF
 FIGURE NUMBERS a THROUGH g

PART NO.	QTY	MODEL/RESTRICTION	MODEL/RESTRICTION	MODEL/RESTRICTION	FROM-TO
67-502B		JOINT, HOSE			
4116-67-502	2				
67-502C		JOINT, ELBOW			
SA70-67-502	1				
67-509		TUBE, CORRUGATE			
G044-67-509	1				
67-509D		TUBE, CORRUGATE			
G033-67-509	1				
67-517		COVER, HOLE-H/FRAME&F EADER GTU, GTUS, (W/O RR WIPER)			
FB01-67-517	2				
67-520A		BRACKET			
FB02-67-520A	1				
76-607A		BUSH, INNER			
FB02-67-402A	2				
76-631A		RUBBER, BLADE-REAR			
FB02-67-331	1				
76-641A		COVER, WIPER ARM-REAR			
B093-76-641	1				
76-671A		TANK, WASHER-RR WIPER			
FB02-67-481	1				
76-672		PUMP, WASHER			
8532-76-672	1				
76-672A		CAP, TANK			
G030-76-673A	1				
87-132A		WASHER			
FB02-67-406	1				
87-804		WASHER			

6750 WINDOW WIPER & WASHER (REAR)

6750 -3 * WINDOW WIPER & WASHER (REAR)

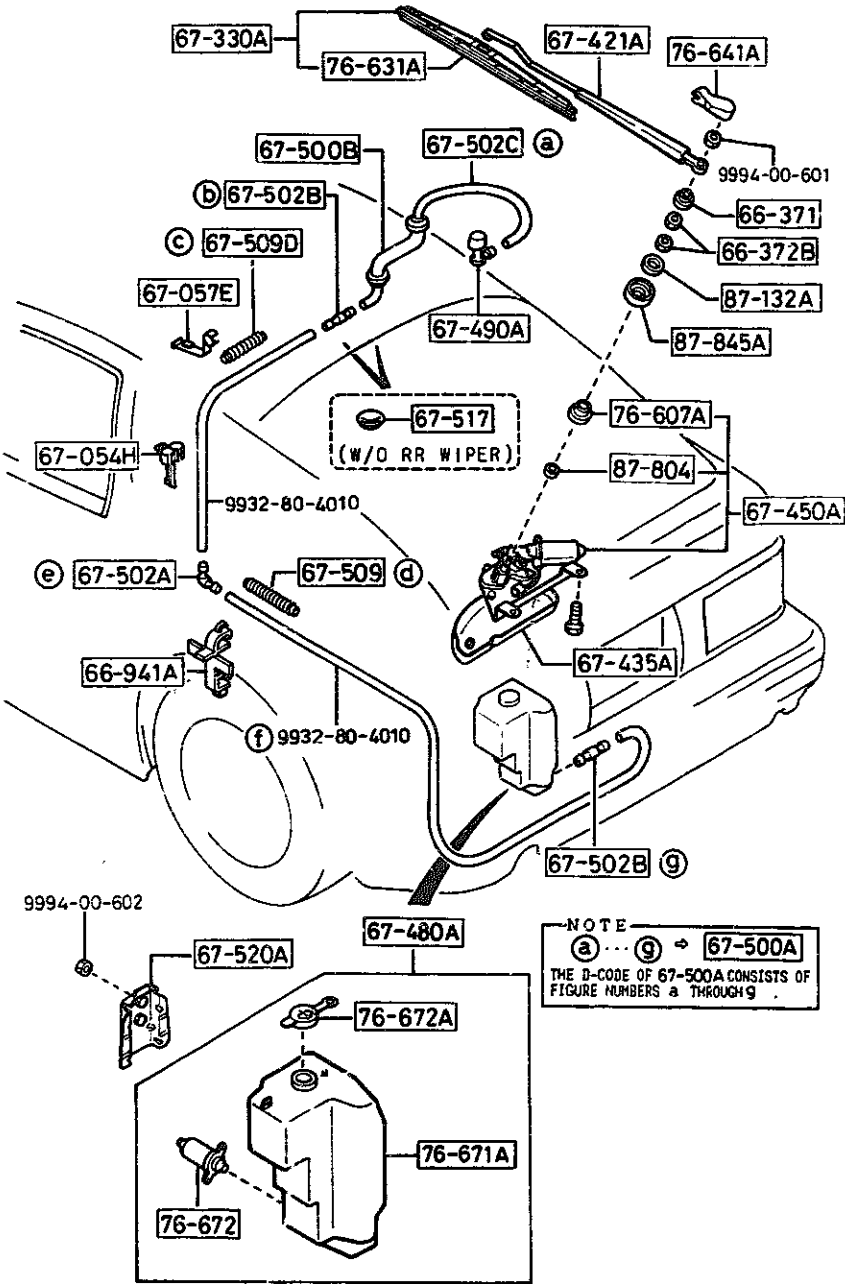

PART NO.	QTY	MODEL/RESTRICTION	MODEL/RESTRICTION	MODEL/RESTRICTION	FROM-TO
CONT'D					
FB03-67-406	1				
87-845A		GASKET			
FB02-67-408A	1				

FROM-TO
 9501-

1992-05

AUFA02

CAT. AUFA02-06

1992-05

6760 WINDOW WIPER MOTOR COMPONENTS (REAR)

COMPONENTS OF FB02-67-450A

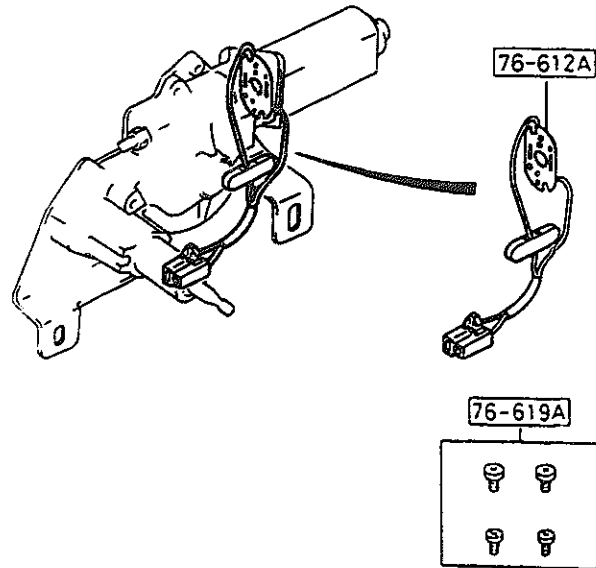
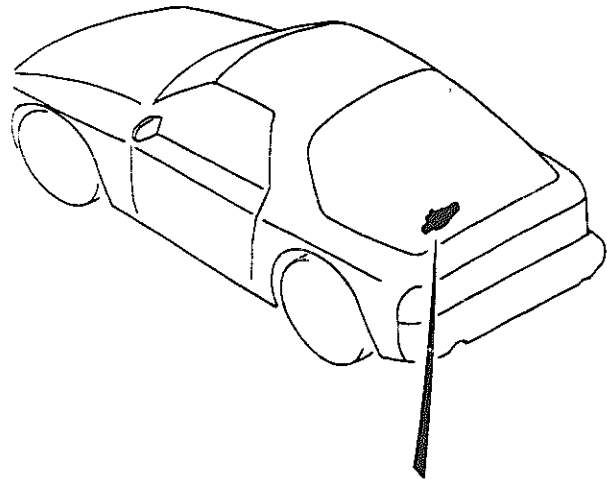

6760 -1 * WINDOW WIPER MOTOR COMPONENTS (REAR)

PART NO.	QTY	MODEL/RESTRICTION	MODEL/RESTRICTION	MODEL/RESTRICTION	FROM-TO
76-612A		PLATE, HOLDER-BRUSH			
FB02-67-451	1				
76-619A		PARTS SET			
B002-76-619A	1				

AUFA02

CAT. AUFA02-06

1992-05

469

684

68-
68-

6
C/W/R
T

68

68

68
1
68
1

AUF

6800 CEILING TRIMS (COUPE)

(SUNROOF)

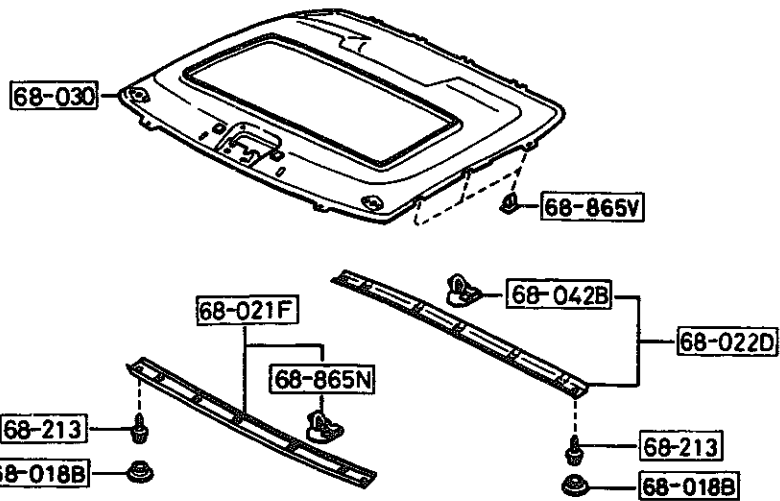

(W/O SUN-RF)

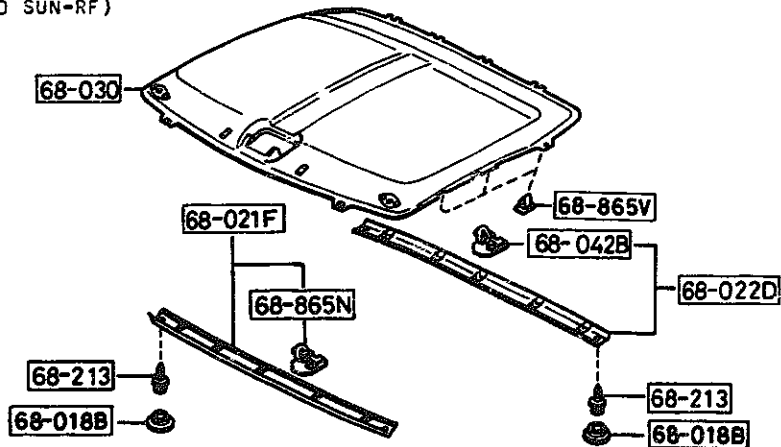

6800 -1 CEILING TRIMS (COUPE)

PART NO.	QTY	MODEL/RESTRICTION	MODEL/RESTRICTION	MODEL/RESTRICTION	FROM-TO
68-018B		CAP			
FB01-68-151	4				
02		FD8 FE1 BLACK			
19		FE0 RED			
48		FD9 BLUE			
68-021F		GARNISH, TOP-FRONT			
FB01-68-020	1				
02		FD8 FE1 BLACK			
19		FE0 RED			
48		FD9 BLUE			
68-022D		GARNISH, TOP-REAR			
FB01-68-040	1				
02		FD8 FE1 BLACK			
19		FE0 RED			
48		FD9 BLUE			
68-030		CEILING, TOP			
FC01-68-030	1	GTU, (UNWOVEN CLOTH) (W/O SUN-RF)			
02		FD8 BLACK			
19		FE0 RED			
48		FD9 BLUE			
FC02-68-030	1	GTU, (KNIT CLOTH) (W/O SUN-RF)			
02		FD8 BLACK			
19		FE0 RED			
48		FD9 BLUE			
FC03-68-030	1	GXL, TURBO, (KNIT CLOTH) (SUNROOF)			
02		FD8 BLACK			
19		FE0 RED			
48		FD9 BLUE			
FC04-68-030	1	GTU, (UNWOVEN CLOTH) (SUNROOF)			

-9301

-9301

9301-

1992-05

AUFA02

CAT. AUFA02-06

1992-05

6800 CEILING TRIMS
(COUPE)

(SUNROOF)

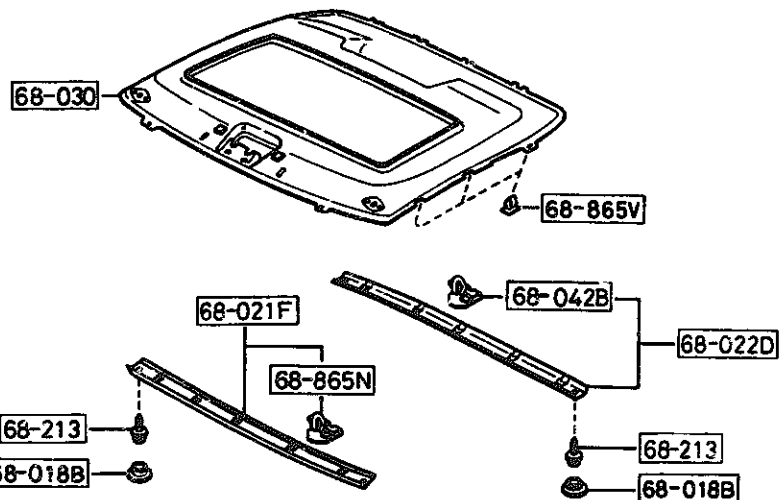

(W/O SUN-RF)

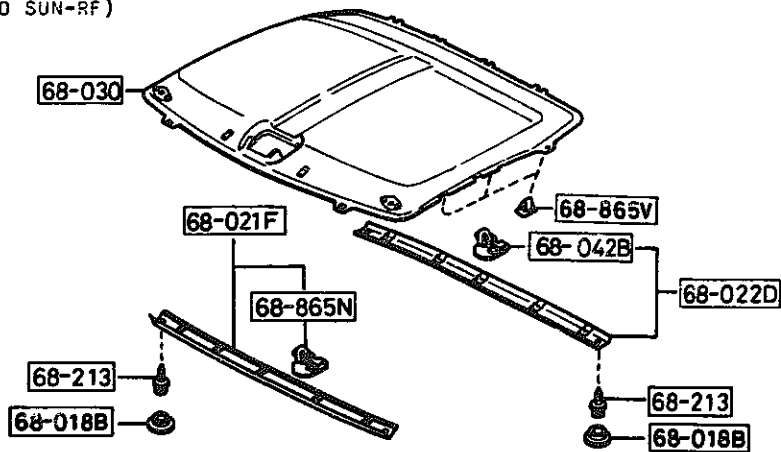

6800 -2 * CEILING TRIMS
(COUPE)

PART NO.	QTY	MODEL/RESTRICTION	MODEL/RESTRICTION	MODEL/RESTRICTION	FROM-TO
CONT'D					
02		FD8 BLACK			
19		FE0 RED			
48		FD9 BLUE			
68-042B		CLIP, GARNISH			
FB01-68-042	5				
68-213		SCREW, TAPPING			
G030-68-213B	4				
68-865N		CLIP, TRIM			
H002-68-865	5				
68-865V		FASTENER, TOP CEILING			
B102-68-012	6				

FROM-TO

-9801

1992-05

AUFA02

CAT. AUFA02-06

1992-05

6800A CEILING TRIMS
(CONVERTIBLE)

6800A -1 * CEILING TRIMS
(CONVERTIBLE)

FROM-TO

PANEL/FABRIC, ROOF
(REFER TO SECT. NO. 6330)

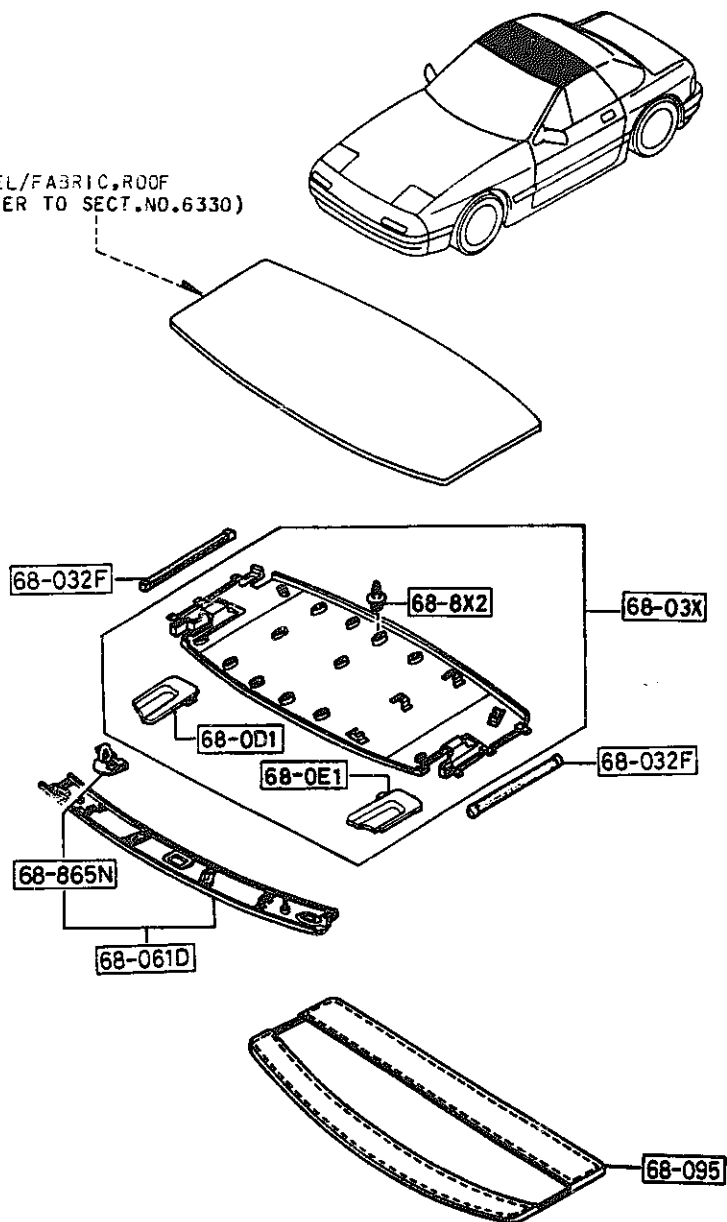

PART NO.	QTY	MODEL/RESTRICTION	MODEL/RESTRICTION	MODEL/RESTRICTION	FROM-TO
68-0D1		LID(R), TOP TRIM			
FB67-68-0D1	1				
02		FD8 FE1 BLACK			
48		FD9 BLUE			
68-0E1		LID(L), TOP TRIM			
FB67-68-0E1	1				
02		FD8 FE1 BLACK			
48		FD9 BLUE			
68-03X		TRIM, TOP			
FB67-68-03XB	1				
02		FD8 FE1 BLACK			
48		FD9 BLUE			
68-032F		WELT, SEAMING-ROOF			
FB67-68-032	2				
02		FD8 FE1 BLACK			
48		FD9 BLUE			
68-061D		TRIM, FRONT HEADER			
FB67-68-020A	1				
02		FD8 FE1 BLACK			
48		FD9 BLUE			
68-095		BAG, ROOF PANEL			
FB67-68-095A	1				
68-8X2		CLIP			
G225-68-8X2	10				
68-865N		CLIP, TRIM			
H002-68-865	2				

1992-05

AUFA02

CAT. AUFA02-06

1992-05

FROM-TO

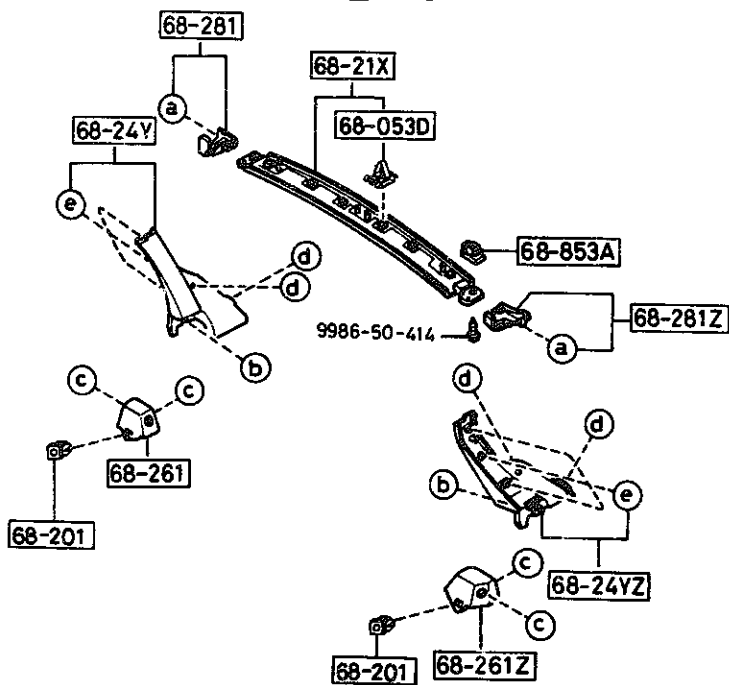
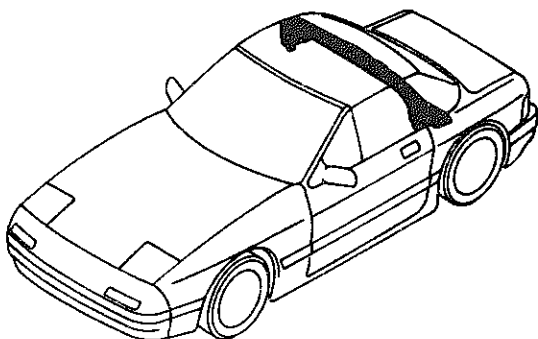

a	b	c	d	e
68-285	68-675	68-865E	68-865Q	68-865S

PART NO.	QTY	MODEL/RESTRICTION	MODEL/RESTRICTION	MODEL/RESTRICTION	FROM-TO
68-053D		CLIP,RR. PILLAR TRIM			
B100-68-279	8				
68-201		GROMMET,SCREW-QTR TRIM			
FB67-68-201	2				
68-21X		TRIM,FORMING BAR			
FB67-68-21XC	1				
02		FD8 FE1 BLACK			
48		FD9 BLUE			
68-24Y		COVER(R),LINK			
FB67-68-24YA	1				
02		FD8 FE1 BLACK			
48		FD9 BLUE			
68-24YZ		COVER(L),LINK			
FB67-68-25YA	1				
02		FD8 FE1 BLACK			
48		FD9 BLUE			
68-261		COVER(R),BELT			
FB67-68-261B	1				
02		FD8 FE1 BLACK			
48		FD9 BLUE			
68-261Z		COVER(L),BELT			
FB67-68-271B	1				
02		FD8 FE1 BLACK			
48		FD9 BLUE			
68-281		COVER(R),HINGE			
FB67-68-28XA A (FB67-68-28XB)	1				-9C01
02		FD8 BLACK			
48		FD9 BLUE			
FB67-68-28XB	1				9C01-
02		FD8 FE1 BLACK			

9C01 FC3***-804800

1992-05

AUFA02

CAT. AUFA02-06

1992-05

4-K 9

FROM TO

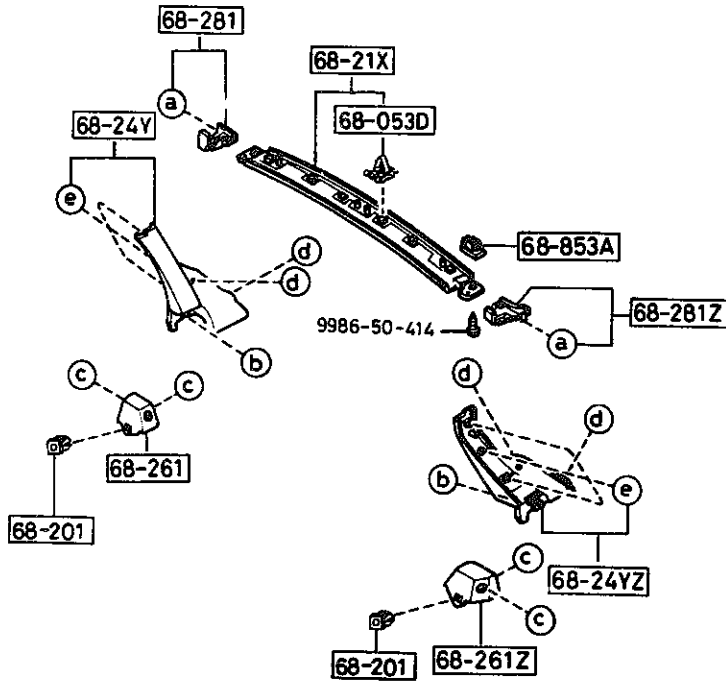
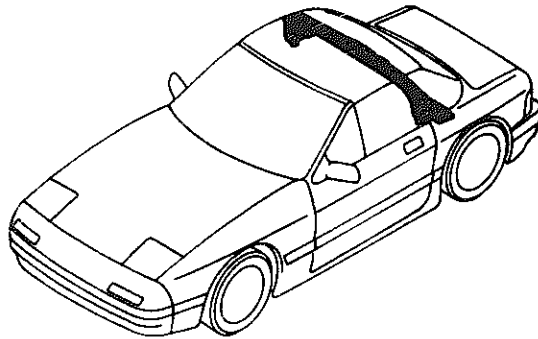

(a)	(b)	(c)	(d)	(e)
68-285	68-675	68-865E	68-865Q	68-865S

PART NO.	QTY	MODEL/RESTRICTION	MODEL/RESTRICTION	MODEL/RESTRICTION	FROM TO
CONT'D					
48		FD9 BLUE			
68-281Z		COVER(L),HINGE			
FB67-68-29XA A (FB67-68-29XB)	1				-9C01
02		FD8 BLACK			
48		FD9 BLUE			
FB67-68-29XB	1				9C01-
02		FD8 FE1 BLACK			
48		FD9 BLUE			
68-285		FASTENER,HINGE COVER			
FB67-68-285	2				
02		FD8 FE1 BLACK			
48		FD9 BLUE			
68-675		FASTENER			
B100-68-675	2				
02		FD8 FE1 BLACK			
48		FD9 BLUE			
68-853A		GROMMET,SCREW-T/SIDE TRIM			
FB02-68-853	2				
68-865E		FASTENER			
S049-68-865	4				
00		FD8 FD9 FE0 FE1 BLACK			
68-865Q		FASTENER			
GJ21-68-885A AN(GJ21-68-885B)	4				-9526
02		FD8 BLACK			
48		FD9 BLUE			
GJ21-68-885B	4				9526-
02		FD8 FE1 BLACK			
48		FD9 BLUE			
68-865S		CLIP,TRIM			

9526 FC3MM-707799
9C01 FC3MM-804800

6810 ROLLEBAR
(CONVERTIBLE)

6810 -3 * ROLLEBAR
(CONVERTIBLE)

FROM-TO

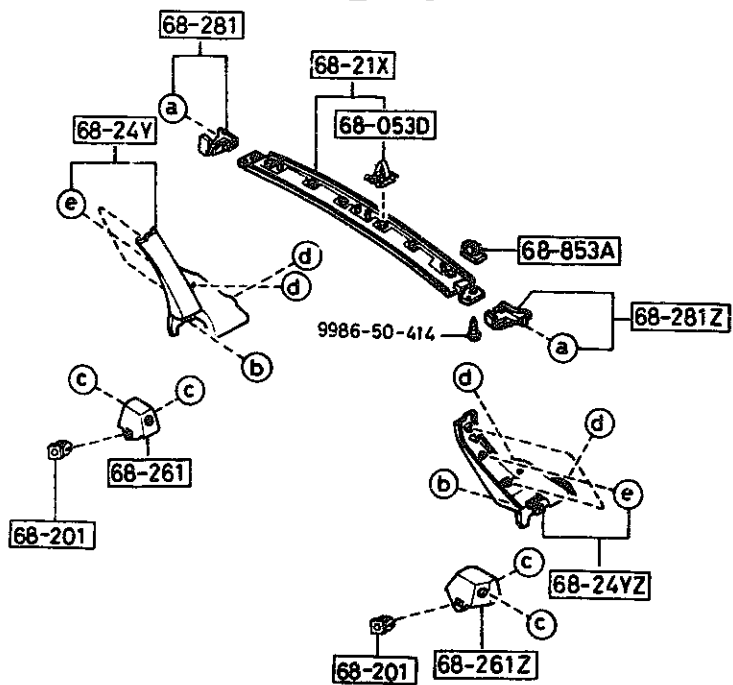
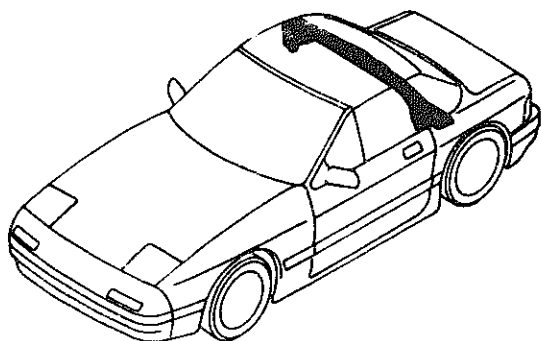

(a)	(b)	(c)	(d)	(e)
68-285	68-675	68-865E	68-865Q	68-865S

PART NO.	QTY	MODEL/RESTRICTION	MODEL/RESTRICTION	MODEL/RESTRICTION	FROM-TO
CONT'D GJ12-68-865	6				

1992-05

AUFA02

CAT. AUFA02-06

1992-05

6820 PILLAR TRIMS
(COUPE)

6820 -1 PILLAR TRIMS
(COUPE)

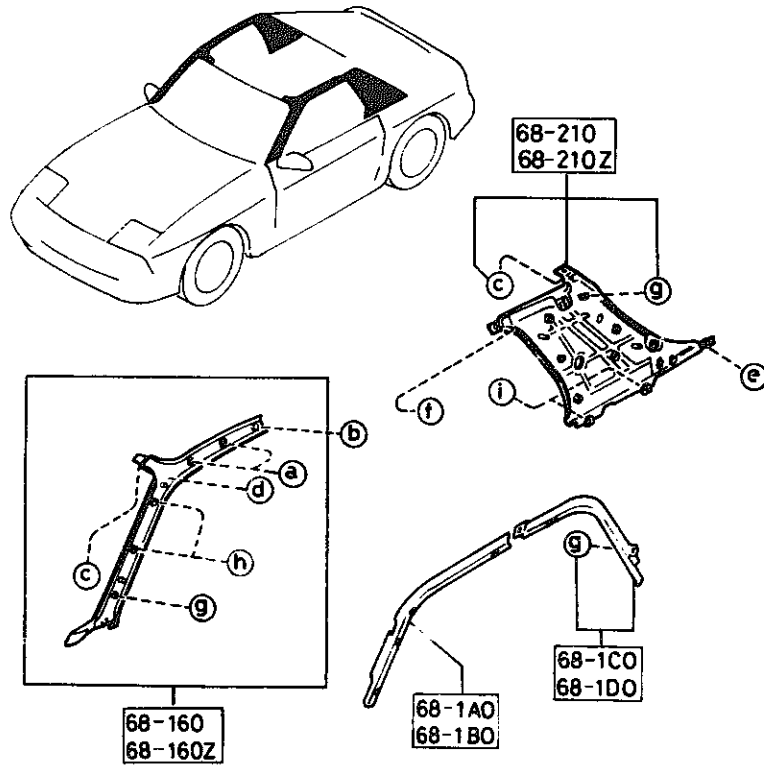

a 68-AD1 	b 68-153A 68-018B 	c 68-155 	d 68-172H 	e 68-719
f 68-853A 	g 68-865N 	h 68-865S 	i 69-885C 	

PART NO.	QTY	MODEL/RESTRICTION	MODEL/RESTRICTION	MODEL/RESTRICTION	FROM-TO
68-AD1		CLIP, SLIDE			
FC01-68-AD1 A (FC01-68-AD1A)	4				-9113
FC01-68-AD1A	4				9113-
68-018B		CAP			
FB01-68-151	2				
02		FD8 FE1 BLACK			
19		FE0 RED			
48		FD9 BLUE			
68-1A0		COVER(R), RAIL-FRT			
FC01-68-1A0B	1				
02		FD8 FE1 BLACK			
19		FE0 RED			
48		FD9 BLUE			
68-1B0		COVER(L), RAIL-FRT			
FC01-68-1B0B	1				
02		FD8 FE1 BLACK			
19		FE0 RED			
48		FD9 BLUE			
68-1C0		COVER(R), RAIL-RR			
FC01-68-1C0A	1				
02		FD8 FE1 BLACK			
19		FE0 RED			
48		FD9 BLUE			
68-1D0		COVER(L), RAIL-RR			
FC01-68-1D0A	1				
02		FD8 FE1 BLACK			
19		FE0 RED			
48		FD9 BLUE			
68-153A		SCREW, TAPPING			
UB39-68-153	2				

9113 FC3MM-700067

AUFA02

CAT. AUFA02-06

1992-05

4-N-9

SECTION NAME INDEX (BODY) 2/2

LO.NO	SEC.NO	SECTION NAME	LO.NO	SEC.NO	SECTION NAME	LO.NO	SEC.NO	SECTION NAME
4-C03	6100	HEATER	4-E08	6703	WIRING HARNESES(DOOR,FLOOR/CEILING)			
4-E03	6110	HEATER UNIT COMPONENTS	4-G08	6704	WIRING HARNESS CLAMPS			
4-F03	6115	HEATER CONTROLS COMPONENTS	4-J08	6720	WINDSHIELD WASHER (1.5L & 2.5L)			
4-G03	6120	HEATER BLOWER COMPONENTS	4-L08	6720 A	WINDSHIELD WASHER (5.7L)			
4-I03	6130	AIR CONDITIONER	4-N08	6730	WINDSHIELD WIPERS			
4-J03	6230	LIFT GATE MECHANISMS (COUPE)	4-C09	6740	WIPER MOTOR COMPONENTS(FRONT)			
4-M03	6300	WINDOW GLASSES (COUPE)	4-D09	6750	WINDOW WIPER & WASHER (REAR)			
4-N03	6300A	WINDOW GLASSES (CONVERTIBLE)	4-G09	6760	WINDOW WIPER MOTOR COMPONENTS (REAR)			
4-C04	6330	SUNROOF (COUPE)	4-H09	6800	CEILING TRIMS (COUPE)			
4-G04	6330A	SUNROOF (CONVERTIBLE)	4-J09	6800A	CEILING TRIMS (CONVERTIBLE)			
4-M04	6600	SWITCHES & RELAYS (ENGINE)	4-K09	6810	ROLLEBAR (CONVERTIBLE)			
4-G05	6610	DASHBOARD SWITCHES	4-N09	6820	PILLAR TRIMS (COUPE)			
4-H05	6611	COMBINATION SWITCH	4-F10	6820A	PILLAR TRIMS (CONVERTIBLE)			
4-I05	6612	CLUSTER SWITCH	4-G10	6840	TRIMS & SCUFF PLATES (COUPE)			
4-L05	6615	POWER WINDOW SWITCHES	4-L10	6840A	TRIMS & SCUFF PLATES (CONVERTIBLE)			
4-M05	6630	RELAYS & UNIT (BODY)	4-N10	6845	STRAGE BOX (COUPE)			
4-D06	6635	DOOR SWITCH & HORNS			(GXL,TURBO)			
4-E06	6640	AUTO CRUISE CONTROL SYSTEM	4-D11	6860	FLOOR MATS & PADS (COUPE)			
4-F06	6680	AUDIO SYSTEMS (RADIO & TAPE DECK) (COUPE)	4-K11	6860A	FLOOR MATS & PADS (CONVERTIBLE)			
4-K06	6680 A	AUDIO SYSTEMS (RADIO & TAPE DECK) (CONVERTIBLE)	4-C12	6870	SERVICE TOOLS			
4-M06	6682	AUDIO SYSTEMS (ANTENNA & SPEAKER) (COUPE)	4-D12	6900	VISORS,ASSIST HANDLES & MIRRORS (COUPE)			
4-D07	6682 A	AUDIO SYSTEMS (ANTENNA & SPEAKER) (CONVERTIBLE)	4-H12	6900A	VISORS,ASSIST HANDLES & MIRRORS (CONVERTIBLE)			
4-G07	6684	AUDIO SYSTEMS(NOISE SUPPRESSOR & EARTH CORD)	4-K12	6930	CAUTION PLATES & LABELS			
4-H07	6700	WIRING HARNESES(FRONT & REAR)	4-N12	7250	QUARTER WINDOW & TRIMS			
4-N07	6701	WIRING HARNESES(ENGINE & TRANSMISSION)	4-E13	7800	SPOILERS & RELATED PARTS			
4-D08	6702	WIRING HARNESES(DASHBOARD)	4-C14	7900	ACCESSORIES			



FROM-TO

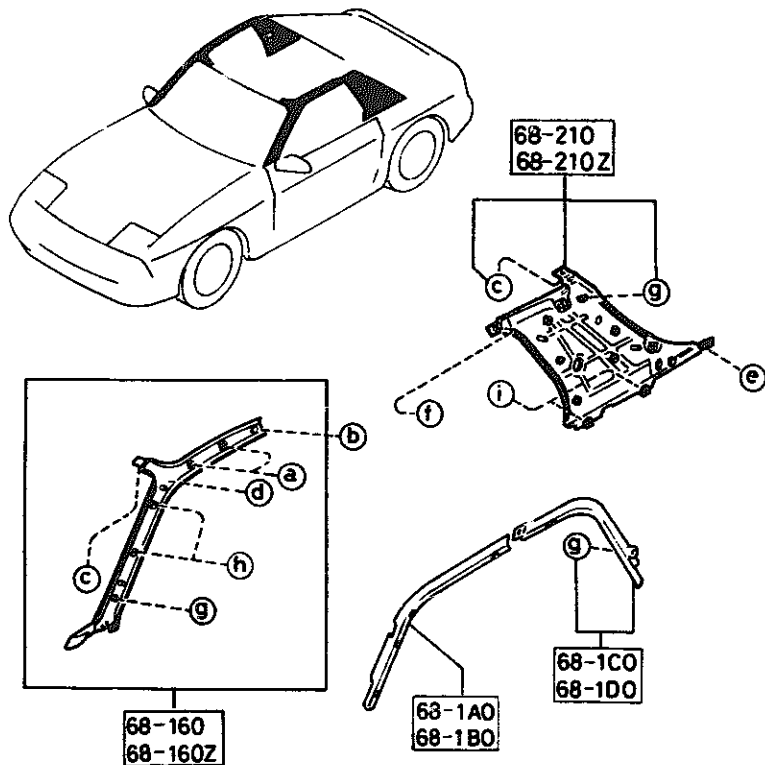

a	b	c	d	e
68-AD1 	68-153A 68-018B 	68-155 	68-172H 	68-719
f	g	h	i	
68-853A 	68-865N 	68-865S 	69-885C 	

PART NO.	QTY	MODEL/RESTRICTION	MODEL/RESTRICTION	MODEL/RESTRICTION	FROM-TO
68-155		GROMMET, SCREW			
FB01-68-155	4				
68-160		TRIM(R), 'A' PILLAR			
FC01-68-160A A (FC01-68-160C)	1				-9113
02		BLACK			
19		RED			
48		BLUE			
FC01-68-160C	1				9113-
02		FD8 FE1 BLACK			
19		FE0 RED			
48		FD9 BLUE			
68-160Z		TRIM(L), 'A' PILLAR			
FC01-68-170A A (FC01-68-170C)	1				-9113
02		BLACK			
19		RED			
48		BLUE			
FC01-68-170C	1				9113-
02		FD8 FE1 BLACK			
19		FE0 RED			
48		FD9 BLUE			
68-172H		FASTENER, CTR. P/UPP.			
B100-68-215A	2				
68-210		TRIM(R), 'B' PILLAR			
FC01-68-190 A (FC01-68-190A)	1				-9113
02		FD8 BLACK			
19		FE0 RED			
48		FD9 BLUE			
FC20-68-190 A (FC20-68-190A)	1				-9113
02		FD8 BLACK			
19		FE0 RED			

9113 FC3MMH-700067

6820 PILLAR TRIMS
(COUPE)

6820 -3 PILLAR TRIMS
(COUPE)

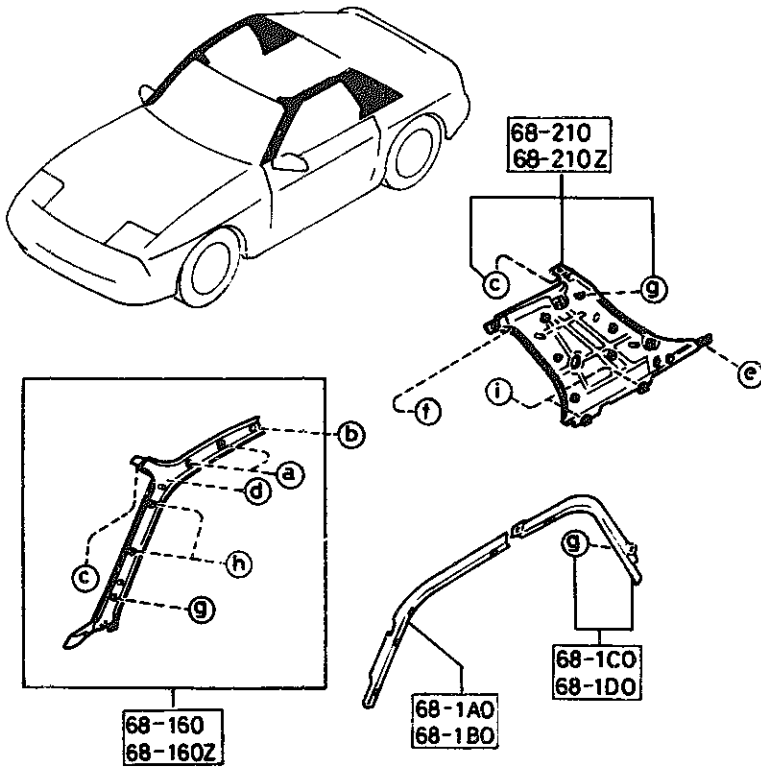

(a) 68-AD1 	(b) 68-153A 68-018B 	(c) 68-155 	(d) 68-172H 	(e) 68-719
(f) 68-853A 	(g) 68-865N 	(h) 68-865S 	(i) 69-885C 	

PART NO.	QTY	MODEL/RESTRICTION	MODEL/RESTRICTION	MODEL/RESTRICTION	FROM-TO
CONT'D					
48		FD9 BLUE			
FC01-68-190A	1	(2SEATER)			9113-
02		FD8 FE1 BLACK			
19		FE0 RED			
48		FD9 BLUE			
FC20-68-190A	1	(4SEATER)			9113-
02		FD8 FE1 BLACK			
19		FE0 RED			
48		FD9 BLUE			
		68-210Z	TRIM(L), 'B' PILLAR		
FC01-68-210	1				-9113
A (FC01-68-210A)					
02		FD8 BLACK			
19		FE0 RED			
48		FD9 BLUE			
FC20-68-210	1				-9113
A (FC20-68-210A)					
02		FD8 BLACK			
19		FE0 RED			
48		FD9 BLUE			
FC01-68-210A	1	(2SEATER)			9113-
02		FD8 FE1 BLACK			
19		FE0 RED			
48		FD9 BLUE			
FC20-68-210A	1	(4SEATER)			9113-
02		FD8 FE1 BLACK			
19		FE0 RED			
48		FD9 BLUE			
		68-719	GROMMET, SCREW		
H001-68-719B	2				
		68-853A	GROMMET, SCREW-T/SIDE TRIM		
FB01-68-853	2				
		68-865N	CLIP, TRIM		

9113 FC3NNK-70067

FPOM-10

1992-05

AUFA02

CAT. AUFA02-06

1992-05

4-D10

6820 PILLAR TRIMS
(COUPE)

6820 -4 * PILLAR TRIMS
(COUPE)

FROM-TO

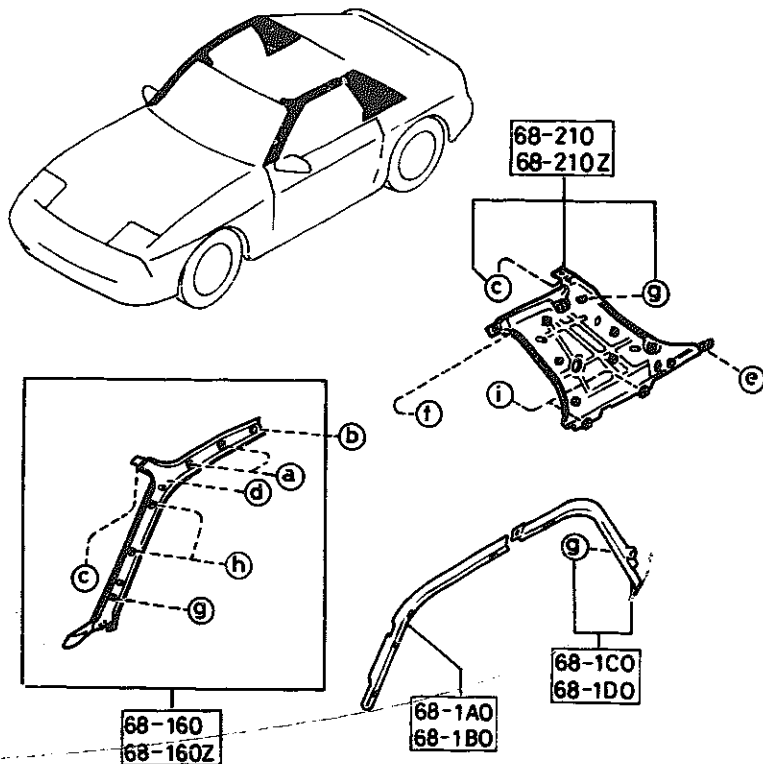

a	b	c	d	e
68-AD1 	68-153A 68-018B 	68-155 	68-172H 	68-719
f	g	h	i	
68-853A 	68-865N 	68-865S 	69-885C 	

PART NO.	QTY	MODEL/RESTRICTION	MODEL/RESTRICTION	MODEL/RESTRICTION	FROM-TO
CONT'D					
H002-68-865	18				
68-865S		CLIP, TRIM			
GJ12-68-865	4				
69-885C		FASTENER			
UB54-68-885	4				
00		FE0 FE1 FE1 BLACK			
48		FD9 BLUE			

1992-05

AUFA02

CAT. AUFA02-06

1992-05

6820A PILLAR TRIMS
(CONVERTIBLE)

6820A -1 * PILLAR TRIMS
(CONVERTIBLE)

FROM-TO

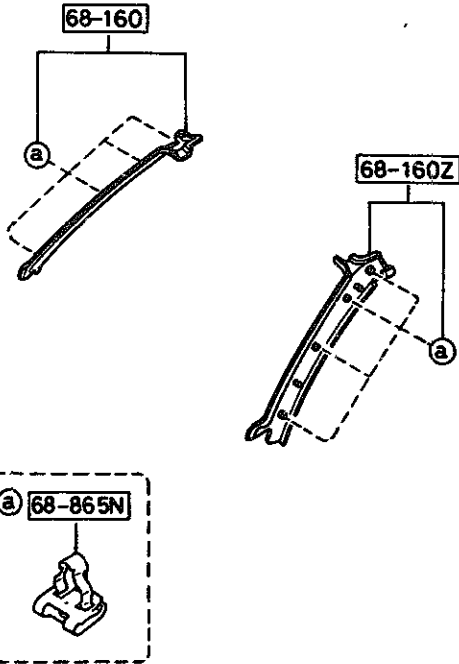
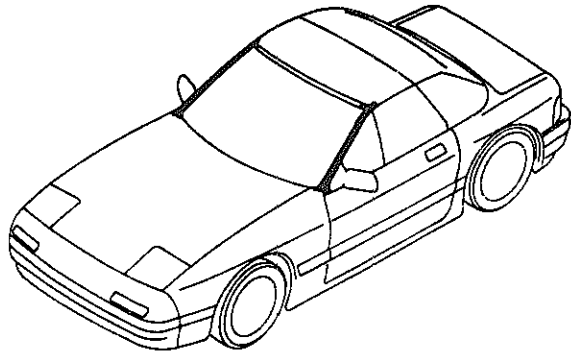

PART NO.	QTY	MODEL/RESTRICTION	MODEL/RESTRICTION	MODEL/RESTRICTION	FROM-TO
68-160		TRIM(R), 'A' PILLAR			
FB67-68-160A	1				
02		F08 FE1 BLACK			
48		FL9 BLUE			
68-160Z		TRIM(L), 'A' PILLAR			
FB67-68-170A	1				
02		F08 FE1 BLACK			
48		FD9 BLUE			
68-865N		CLIP, TRIM			
HD02-68-865	8				

1992-05

AUFA02

CAJ. AUFA02-06

1992-05

4 F10

FROM-TO

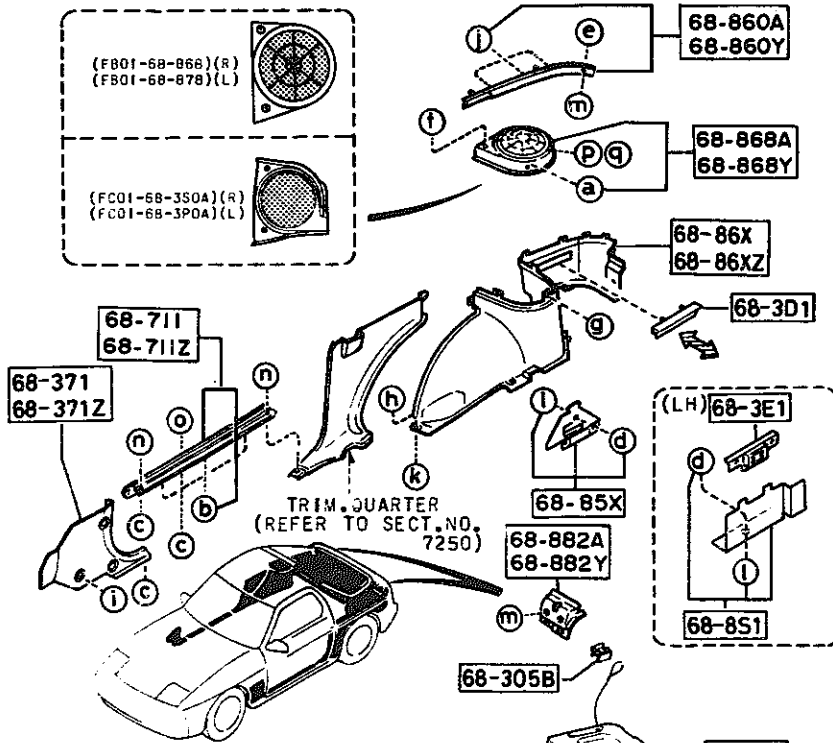

a	b	c				
68-3E3 (W/RR PACKAGE TRAY TRIM)	68-712B	68-719				
d	e	f	g	h	i	j
68-852	68-853A	68-865	68-865C	68-865D	68-865E	68-865N
k	l	m	n	o	p	q
68-866C	9957-50-600	9986-40-416B	9986-40-430B	9976-90-416B	9986-50-416B	9991-00-401

PART NO.	QTY	MODEL/RESTRICTION	MODEL/RESTRICTION	MODEL/RESTRICTION	FROM-TO
68-3D1		BRACKET(R), RR PKG			
FC01-68-3D1	1				
02		FD8 FD9 FE0 BLACK			
68-3E		BRACKET(L), RR PKG			
FC01-68-3E1	1				
02		FD8 FD9 FE0 BLACK			
68-3E3		HOLDER, HINGE-GRILLE			
FC01-68-3E3A	2				
68-305B		HANGER, STRAP			
FC01-68-301A	2				
68-320		TRAY, REAR PACKAGE			
FC01-68-310C A (FC01-68-310D)	1				-9117
02		FD8 BLACK			
19		FD0 RED			
48		FD9 BLUE			
FC20-68-310A A (FC20-68-310B)	1				-9117
02		FD8 BLACK			
19		FD0 RED			
48		FD9 BLUE			
FC01-68-310D	1 (2SEATER)				9117-
02		FD8 BLACK			
19		FE0 RED			
48		FD9 BLUE			
FC20-68-310B	1 (4SEATER)				9117-
02		FD8 BLACK			
19		FE0 RED			
48		FD9 BLUE			
68-371		TRIM(R), FRONT SIDE			
FB01-68-370	1				
02		FD8 FE1 BLACK			
19		FE0 RED			
9117 FC3XXX-700199					

1992-05

AUFA02

CAT. AUFA02-06

1992-05

4-G10

6840 TRIMS & SCUFF PLATES
(COUPE)

6840 -2 TRIMS & SCUFF PLATES
(COUPE)

FROM-TO

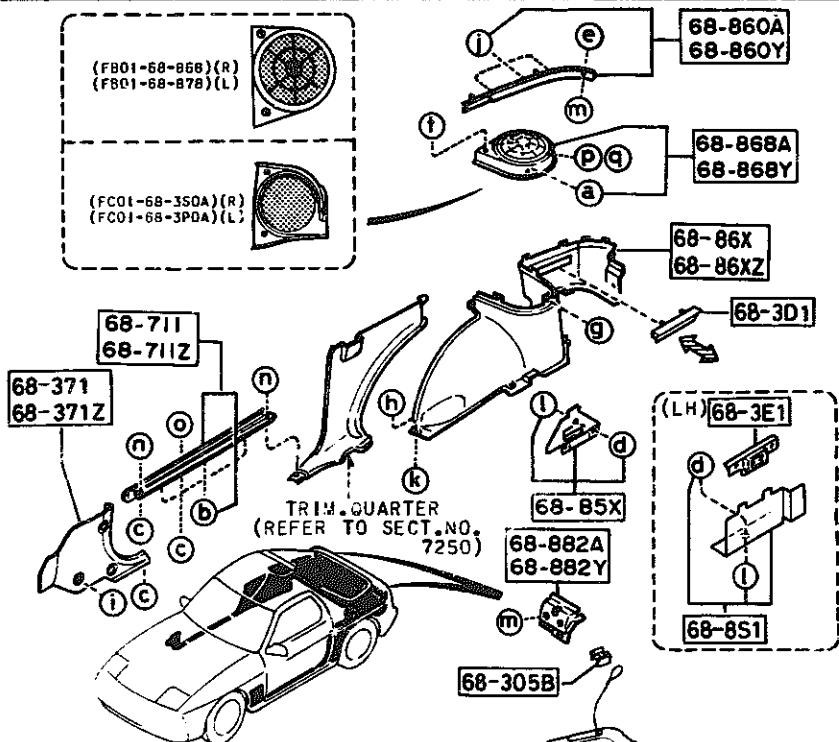

(a)	(b)	(c)				
68-3E3 (W/RR PACKAGE TRAY TRIM)	68-712B	68-719				
(d)	(e)	(f)	(g)	(h)	(i)	(j)
68-852	68-853A	68-865	68-865C	68-865D	68-865E	68-865N
(k)	(l)	(m)	(n)	(o)	(p)	(q)
68-866C	9957-50-800	9986-40-416B	9986-40-430B	9976-90-416B	9986-50-416B	9991-00-401

PART NO.	QTY	MODEL/RESTRICTION	MODEL/RESTRICTION	MODEL/RESTRICTION	FROM-TO
CONT'D					
48		FD9 BLUE			
68-371Z		TRIM(L), FRONT SIDE			
FB01-68-390	1				
02		FD8 FE1 BLACK			
19		FE0 RED			
48		FD9 BLUE			
68-711		PLATE(R), FRONT SCUFF			
FB01-68-710A	1				
02		FD8 FE1 BLACK			
19		FE0 RED			
48		FD9 BLUE			
68-711Z		PLATE(L), FRONT SCUFF			
FB01-68-720A	1				
02		FD8 FE1 BLACK			
19		FE0 RED			
48		FD9 BLUE			
68-712B		CLIP			
B003-68-712	2				
68-719		GROMMET, SCREW			
H001-68-719B	10				
68-851		COVER, JACK			
FC01-68-850	1				
02		FD8 BLACK			
19		FE0 RED			
48		FD9 BLUE			
68-85X		LID, SIDE-TRUNK ROOM			
FB01-68-85X	1				
68-852		FASTENER, TURN-SIDE L ID			
FB01-68-852	3				

1992-05

AUFA02

CAT. AUFA02-06

1992-05

4-H10

6840 TRIMS & SCUFF PLATES
(COUPE)

6840 -3 TRIMS & SCUFF PLATES
(COUPE)

FROM-TO

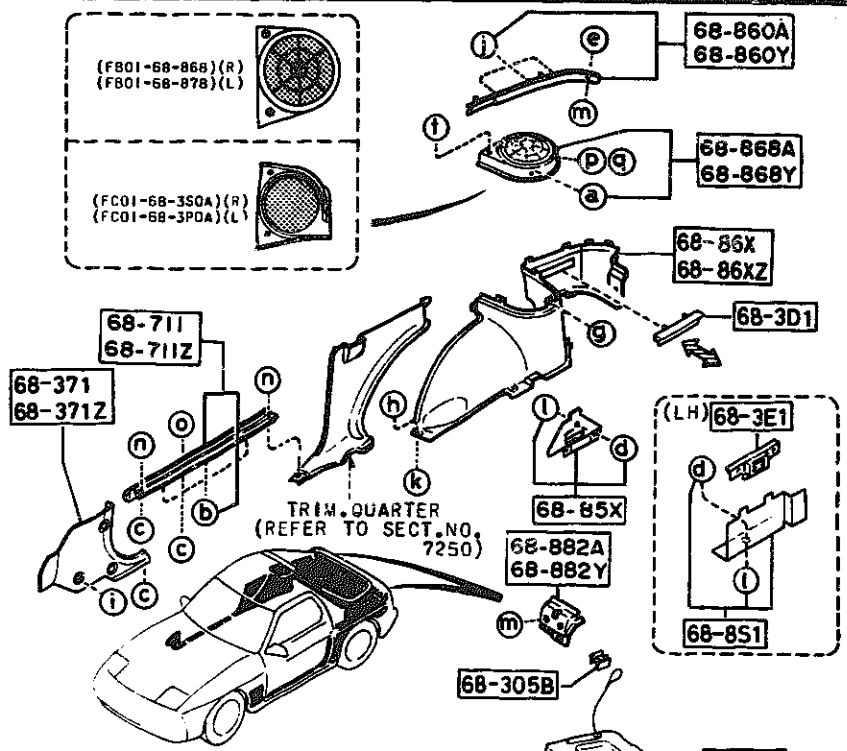

a	b	c				
68-3E3 (W/RR PACKAGE TRAY TRIM)	68-712B	68-719				
d	e	f	g	h	i	j
68-852	68-853A	68-865	68-865C	68-865D	68-865E	68-865N
k	l	m	n	o	p	q
68-866C	9957-50-600	9986-40-416B	9986-40-430B	9976-90-416B	9986-50-416B	9991-00-401

PART NO.	QTY	MODEL/RESTRICTION	MODEL/RESTRICTION	MODEL/RESTRICTION	FROM-TO
68-853A		GROMMET, SCREW-T/SIDE TRIM			
F802-68-853	2				
68-86X		TRIM(R), TRUNK SIDE-L OWER			
FC01-68-85Y	1	GTU, GTUS, (W/O SILENCER PAD) (2SEATER)			
02		FD8 BLACK			
19		FEO RED			
48		FD9 BLUE			
FC04-68-85Y	1	GXL, TURBO, (W/SILENCER PAD) (2SEATER)			
02		FD8 BLACK			
19		FEO RED			
48		FD9 BLUE			
FC22-68-85Y	1	(4SEATER)			
02		FD8 BLACK			
19		FEO RED			
48		FD9 BLUE			
68-86XZ		TRIM(L), TRUNK SIDE-L OWER			
FC01-68-87Y	1	GTU, GTUS, (W/O SILENCER PAD) (2SEATER)			
02		FD8 BLACK			
19		FEO RED			
48		FD9 BLUE			
FC04-68-87Y	1	GXL, TURBO, (W/SILENCER PAD) (2SEATER)			
02		FD8 BLACK			
19		FEO RED			
48		FD9 BLUE			
FC22-68-87Y	1	(4SEATER)			
02		FD8 BLACK			
19		FEO RED			
48		FD9 BLUE			

1992-05

AUFA02

CAT. AUFA02-06

1992-05

6840 TRIMS & SCUFF PLATES (COUPE)

6840 -4 TRIMS & SCUFF PLATES (COUPE)

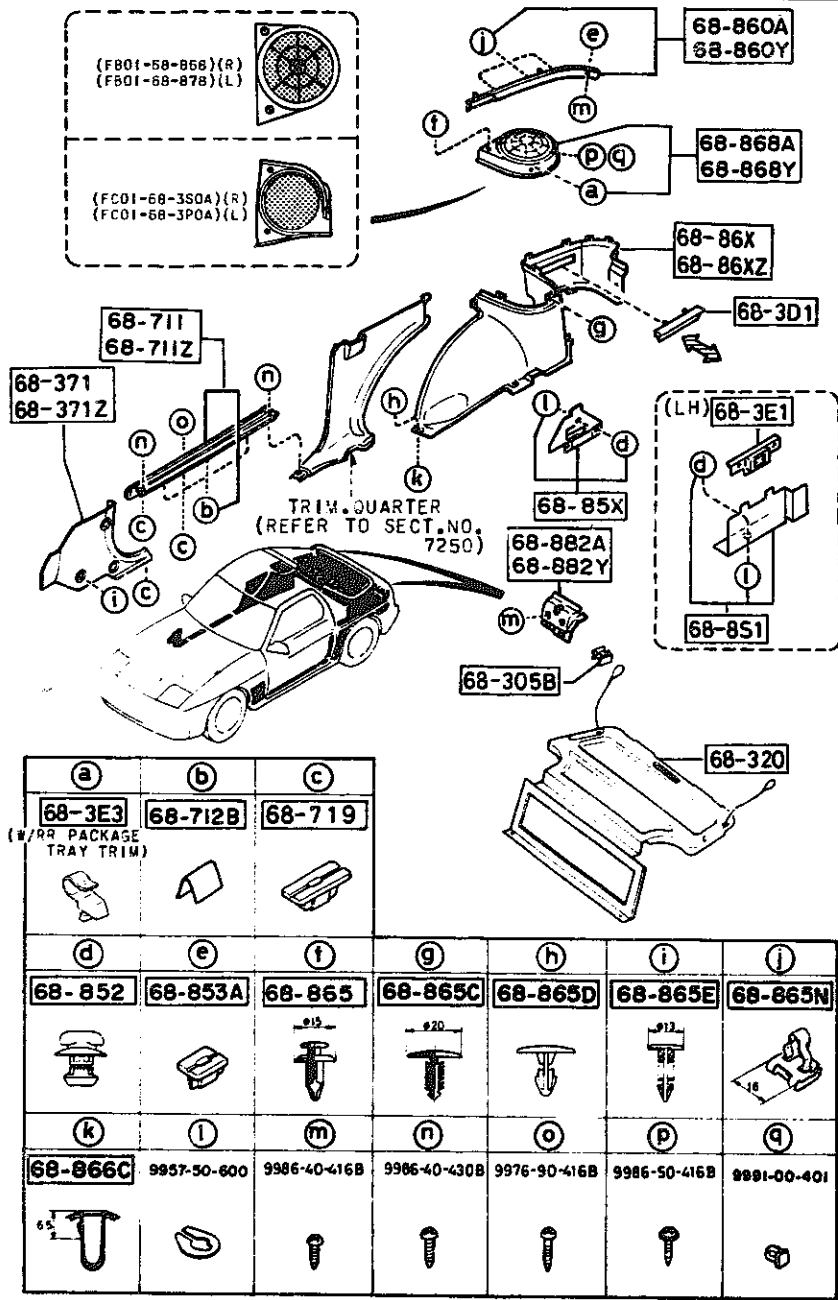

PART NO.	QTY	MODEL/RESTRICTION	MODEL/RESTRICTION	MODEL/RESTRICTION	FROM TO
68-860A		TRIM(R), TRUNK SIDE-UPPER			
FB01-68-860	1				
02		FD8 FE1 BLACK			
19		FE0 RED			
48		FD9 BLUE			
68-860Y		TRIM(L), TRUNK SIDE-UPPER			
FB01-68-870	1				
02		FD8 FE1 BLACK			
19		FE0 RED			
48		FD9 BLUE			
68-865		FASTENER			
8040-68-865A	4				
00		FD8 BLACK			
19		FE0 RED			
48		FD9 BLUE			
68-865C		FASTENER			
G032-68-865A	16				
00		FD8 FE1 BLACK			
68-865D		FASTENER			
S083-68-865A	7				
00		FD8 FE1 BLACK			
68-865E		FASTENER			
S049-68-865	6				
00		FD8 FD9 FE0 FE1 BLACK			
68-865N		CLIP, TRIM			
H002-68-865	6				
68-866C		FASTENER, SEAL			
B235-68-865A	7				
B235-68-865A	5				
-9A01					
9A01-					
9A01 FC3RRR-803554					

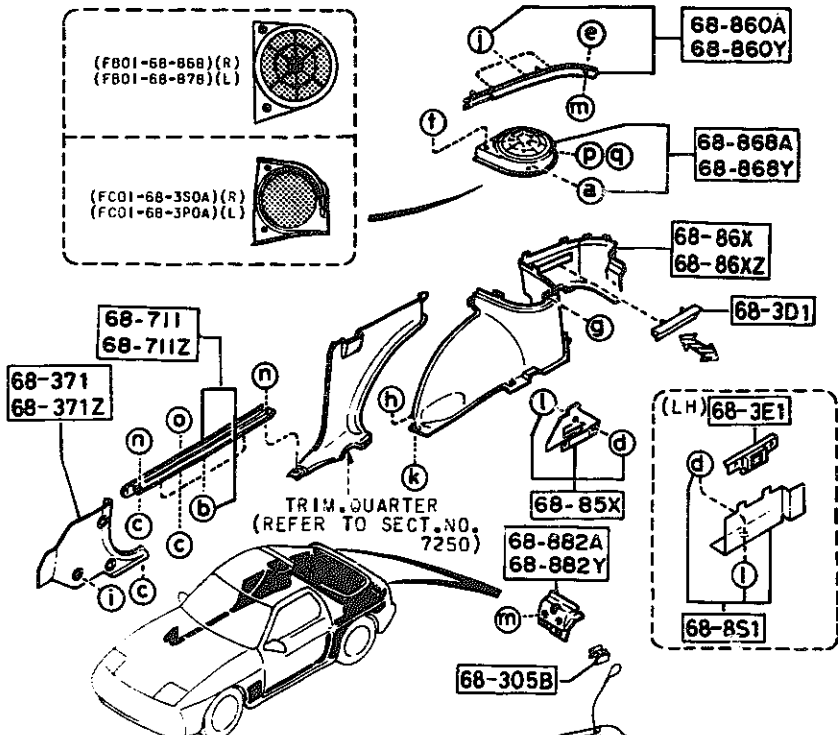

a	b	c	d	e	f	g	h	i	j
68-3E3 (W/RR PACKAGE TRAY TRIM)	68-712B	68-719	68-852	68-853A	68-865	68-865C	68-865D	68-865E	68-865N
k	l	m	n	o	p	q			
68-866C	9957-50-600	9586-40-416B	9586-40-430B	9576-90-416B	9586-50-416B	9991-00-401			

PART NO.	QTY	MODEL/RESTRICTION	MODEL/RESTRICTION	MODEL/RESTRICTION	FROM-TO
68-868A		GRILLE(R),SPEAKER-T/TRIM			
FC01-68-350A	1	GXL, TURBO, (W/RR PACKAGE TRAY TRIM)			
02		FD8 BLACK			
19		FEO RED			
48		FD9 BLUE			
FB01-68-868	1	GTU, GTUS, (W/D RR PACKAGE TRAY TRIM) (2SEATER)			
02		FD8 BLACK			
19		FEO RED			
48		FD9 BLUE/BLACK			
68-868Y		GRILLE(L),SPEAKER-T/TRIM			
FC01-68-3P0A	1	GXL, TURBO, (W/RR PACKAGE TRAY TRIM)			
02		FD8 BLACK			
19		FEO RED			
48		FD9 BLUE			
FB01-68-878	1	GTU, GTUS, (W/D RR PACKAGE TRAY TRIM) (2SEATER)			
02		FD8 BLACK			
19		FEO RED			
48		FD9 BLUE/BLACK			
68-882A		COVER(R),T-END TRIM			
FB01-68-894B	1				
02		FD8 FE1 BLACK			
19		FEO RED			
48		FD9 BLUE			
68-882Y		COVER(L),T-END TRIM			
FB01-68-895B	1				
02		FD8 FE1 BLACK			
19		FEO RED			
48		FD9 BLUE			

6840A TRIMS & SCUFF PLATES
(CONVERTIBLE)

6840A -1 TRIMS & SCUFF PLATES
(CONVERTIBLE)

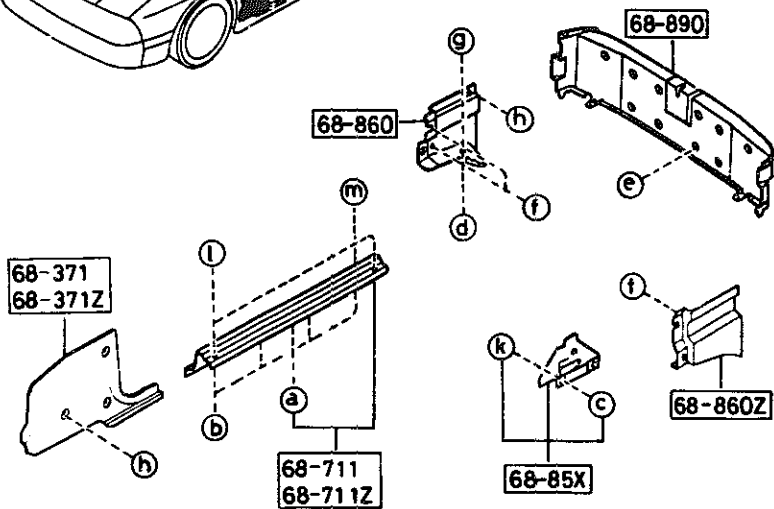
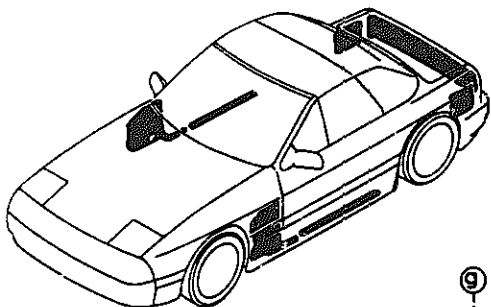

a	b	c	d	e	f	g
68-712B	68-719	68-852	68-866C	68-865	68-865C	68-865D
h			k	l		m
68-865E			9957-50-600	9986-40-430B		9976-90-416B

PART NO.	QTY	MODEL/RESTRICTION	MODEL/RESTRICTION	MODEL/RESTRICTION	FROM-TO
68-371		TRIM(R),FRONT SIDE			
FB67-68-370	1				
02		FD8 FE1 BLACK			
48		FD9 BLUE			
68-371Z		TRIM(L),FRONT SIDE			
FB67-68-390	1				
02		FD8 FE1 BLACK			
48		FD9 BLUE			
68-711		PLATE(R),FRONT SCUFF			
FB67-68-710	1				
02		FD8 FE1 BLACK			
48		FD9 BLUE			
68-711Z		PLATE(L),FRONT SCUFF			
FB67-68-720	1				
02		FD8 FE1 BLACK			
48		FD9 BLUE			
68-712B		CLIP			
B235-68-712	2				
68-719		GROMMET,SCREW			
B235-68-719	8				
68-85X		LID,SIDE-TRUNK ROOM			
FR01-68-85X	1				
68-852		FASTENER,TURN-SIDE LID			
FR01-68-852	2				
68-860		TRIM(R),TRUNK SIDE			
FB67-68-861	1				
07		FD8 FD9 FE1 DARK GRAY			
68-860Z		TRIM(L),TRUNK SIDE			
FB67-68-871	1				

AUFA02

CAT. AUFA02-06

1992-05

6840A TRIMS & SCUFF PLATES
(CONVERTIBLE)

6840A -2 * TRIMS & SCUFF PLATES
(CONVERTIBLE)

FROM-TO

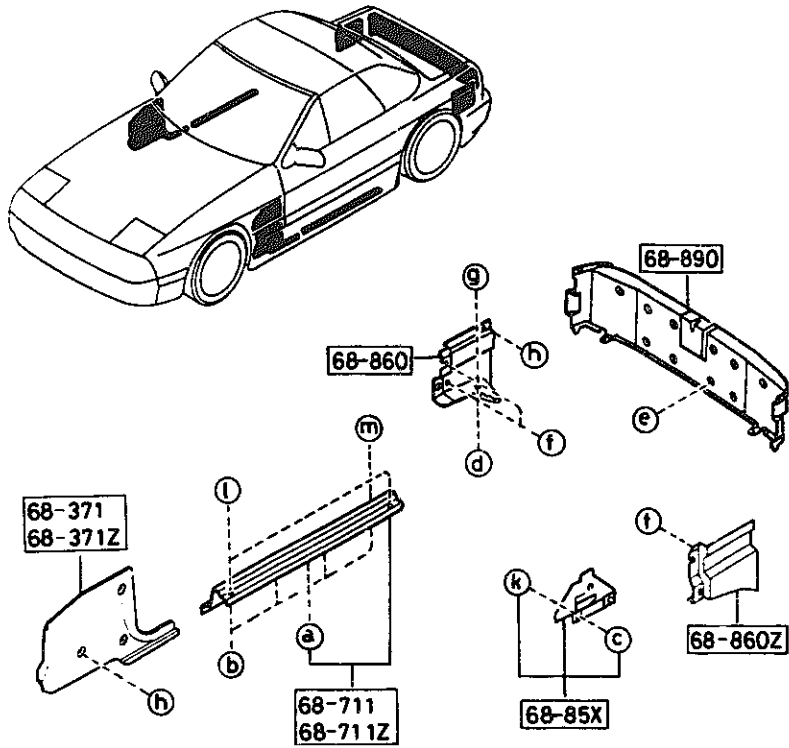

a	b	c	d	e	f	g
68-712B	68-719	68-852	68-866C	68-865	68-865C	68-865D
h			k	l		m
68-865E			9957-50-600	9986-40-430B	9976-90-416B	

PART NO.	QTY	MODEL/RESTRICTION	MODEL/RESTRICTION	MODEL/RESTRICTION	FROM-TO
CONT'D					
07		FD8 FD9 FE1 DARK GRAY			
68-865		FASTENER			
FB67-68-865	13				
09		FD8 FD9 FE1 DARK GRAY			
68-865C		FASTENER			
G032-68-865A	7				
09		FE0 FE1 DARK GRAY			
48		FD9 BLUE			
68-865D		FASTENER			
S083-68-865A	1				
09		FE0 FE1 DARK GRAY			
48		FD9 BLUE			
68-865E		FASTENER			
S049-68-865	6				
00		FE0 FE1 BLACK			
48		FD9 BLUE			
68-866C		FASTENER, SEAL			
B235-68-865A	1				
68-890		TRIM, TRUNK END			
FB67-68-891B	1				
07		FD8 FD9 FE1 DARK GRAY			

1992-05

AUFA02

CAT. AUFA02-06

1992-05

4-M10

6845 STRAGE BOX
(COUPE)
(GXL, TURBO)

6845 -1 STRAGE BOX
(COUPE)
(GXL, TURBO)

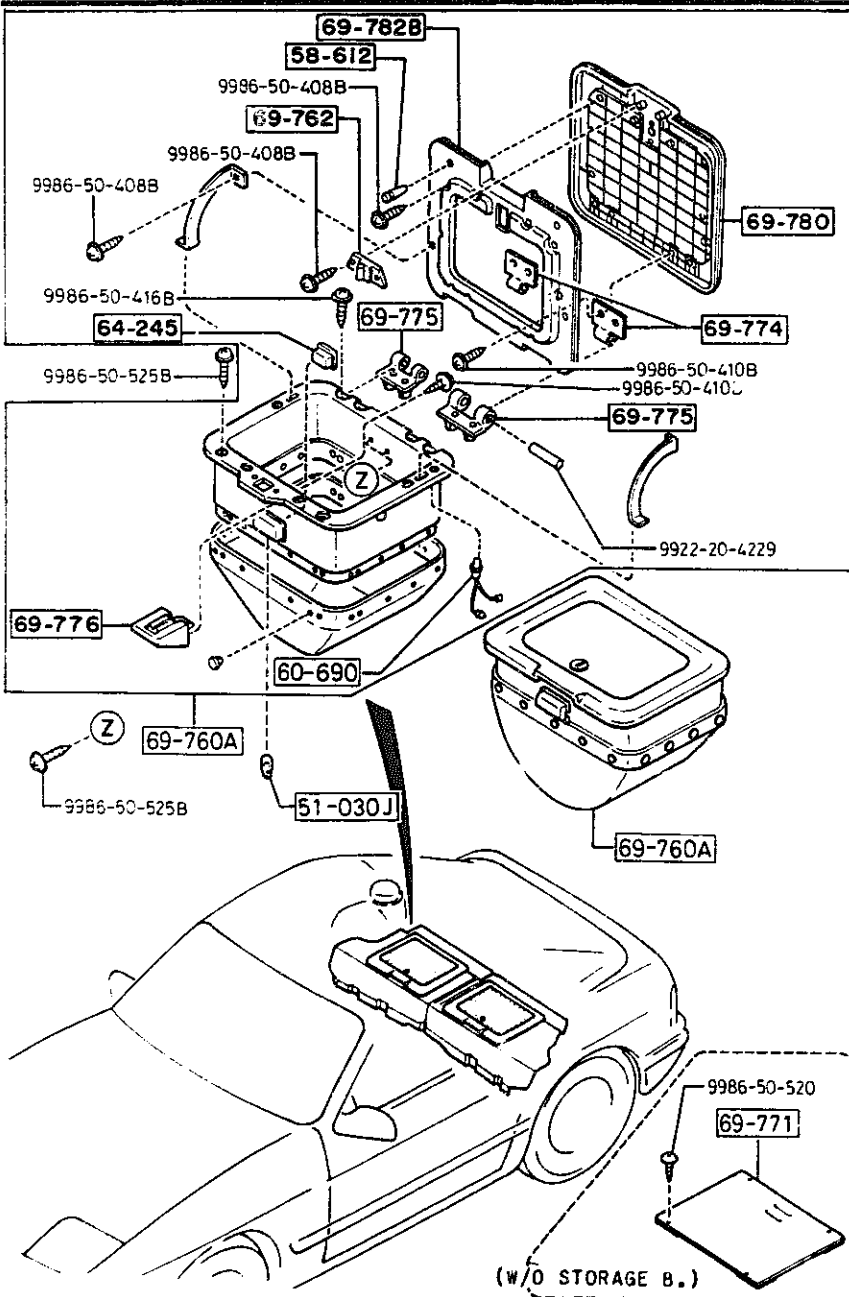

PART NO.	QTY	MODEL/RESTRICTION	MODEL/RESTRICTION	MODEL/RESTRICTION	FROM-TO
51-030J		BULB			
99701-6030	2	12V 3.4W			
58-612		CUSHION, RUBBER			
0259-58-612	4				
60-690		SWITCH, GLOVE TRAY			
G030-66-540B	2				
64-245		LENS, SIDE WALL			
H002-64-245	2				
69-760A		BOX, STORAGE			
FC01-69-760	2				
02		FD8 BLACK			
19		FED RED			
48		FD9 BLUE			
69-762		PLATE, LOCK			
FB01-69-762	2				
02		FD8 BLACK			
19		FED RED			
48		FD9 BLUE			
69-771		COVER, HOLE-STORAGE BOX			
FB02-69-771	2	(W/O STORAGE BOX)			
69-774		HINGE NO.1, STORAGE BOX			
FB01-69-774	4				
07		DARK GRAY			
10		RED			
48		BLUE			
69-775		HINGE NO.2, STORAGE BOX			
FB01-69-775	4				
07		DARK GRAY			
10		RED			
48		BLUE			

FROM-TO

-9113

9113-

1992-05

AUFA02

CAT. AUFA02-06

1992-05

4-N10

SECTION NAME INDEX (BODY) 2/2

LO.NO	SEC.NO	SECTION NAME	LO.NO	SEC.NO	SECTION NAME	LO.NO	SEC.NO	SECTION NAME
4-C03	6100	HEATER	4-E08	6703	WIRING HARNESSSES(DOOR,FLOOR/CEILING)			
4-E03	6110	HEATER UNIT COMPONENTS	4-G08	6704	WIRING HARNESS CLAMPS			
4-F03	6115	HEATER CONTROLS COMPONENTS	4-J08	6720	WINDSHIELD WASHER (1.5L & 2.5L)			
4-G03	6120	HEATER BLOWER COMPONENTS	4-L08	6720 A	WINDSHIELD WASHER (5.7L)			
4-I03	6130	AIR CONDITIONER	4-N08	6730	WINDSHIELD WIPERS			
4-J03	6230	LIFT GATE MECHANISMS (COUPE)	4-C09	6740	WIPER MOTOR COMPONENTS(FRONT)			
4-M03	6300	WINDOW GLASSES (COUPE)	4-D09	6750	WINDOW WIPER & WASHER (REAR)			
4-N03	6300A	WINDOW GLASSES (CONVERTIBLE)	4-G09	6760	WINDOW WIPER MOTOR COMPONENTS (REAR)			
4-C04	6330	SUNROOF (COUPE)	4-H09	6800	CEILING TRIMS (COUPE)			
4-G04	6330A	SUNROOF (CONVERTIBLE)	4-J09	6800A	CEILING TRIMS (CONVERTIBLE)			
4-M04	6600	SWITCHES & RELAYS (ENGINE)	4-K09	6810	ROLLEBAR (CONVERTIBLE)			
4-G05	6610	DASHBOARD SWITCHES	4-N09	6820	PILLAR TRIMS (COUPE)			
4-H05	6611	COMBINATION SWITCH	4-F10	6820A	PILLAR TRIMS (CONVERTIBLE)			
4-I05	6612	CLUSTER SWITCH	4-G10	6840	TRIMS & SCUFF PLATES (COUPE)			
4-L05	6615	POWER WINDOW SWITCHES	4-L10	6840A	TRIMS & SCUFF PLATES (CONVERTIBLE)			
4-M05	6630	RELAYS & UNIT (BODY)	4-N10	6845	STRAGE BOX (COUPE)			
4-D06	6635	DOOR SWITCH & HORNS			(GXL,TURBO)			
4-E06	6640	AUTO CRUISE CONTROL SYSTEM	4-D11	6860	FLOOR MATS & PADS (COUPE)			
4-F06	6680	AUDIO SYSTEMS (RADIO & TAPE DECK) (COUPE)	4-K11	6860A	FLOOR MATS & PADS (CONVERTIBLE)			
4-K06	6680 A	AUDIO SYSTEMS (RADIO & TAPE DECK) (CONVERTIBLE)	4-C12	6870	SERVICE TOOLS			
4-M06	6682	AUDIO SYSTEMS (ANTENNA & SPEAKER) (COUPE)	4-D12	6900	VISORS,ASSIST HANDLES & MIRRORS (COUPE)			
4-D07	6682 A	AUDIO SYSTEMS (ANTENNA & SPEAKER) (CONVERTIBLE)	4-H12	6900A	VISORS,ASSIST HANDLES & MIRRORS (CONVERTIBLE)			
4-G07	6684	AUDIO SYSTEMS(NOISE SUPPRESSOR & EARTH CORD)	4-K12	6930	CAUTION PLATES & LABELS			
4-H07	6700	WIRING HARNESSSES(FRONT & REAR)	4-N12	7250	QUARTER WINDOW & TRIMS			
4-N07	6701	WIRING HARNESSSES(ENGINE & TRANSMISSION)	4-E13	7800	SPOILERS & RELATED PARTS			
4-D08	6702	WIRING HARNESSSES(DASHBOARD)	4-C14	7900	ACCESSORIES			



6845 STRAGE BOX
(COUPE)
(GXL, TURBO)

6845 -2 * STRAGE BOX
(COUPE)
(GXL, TURBO)

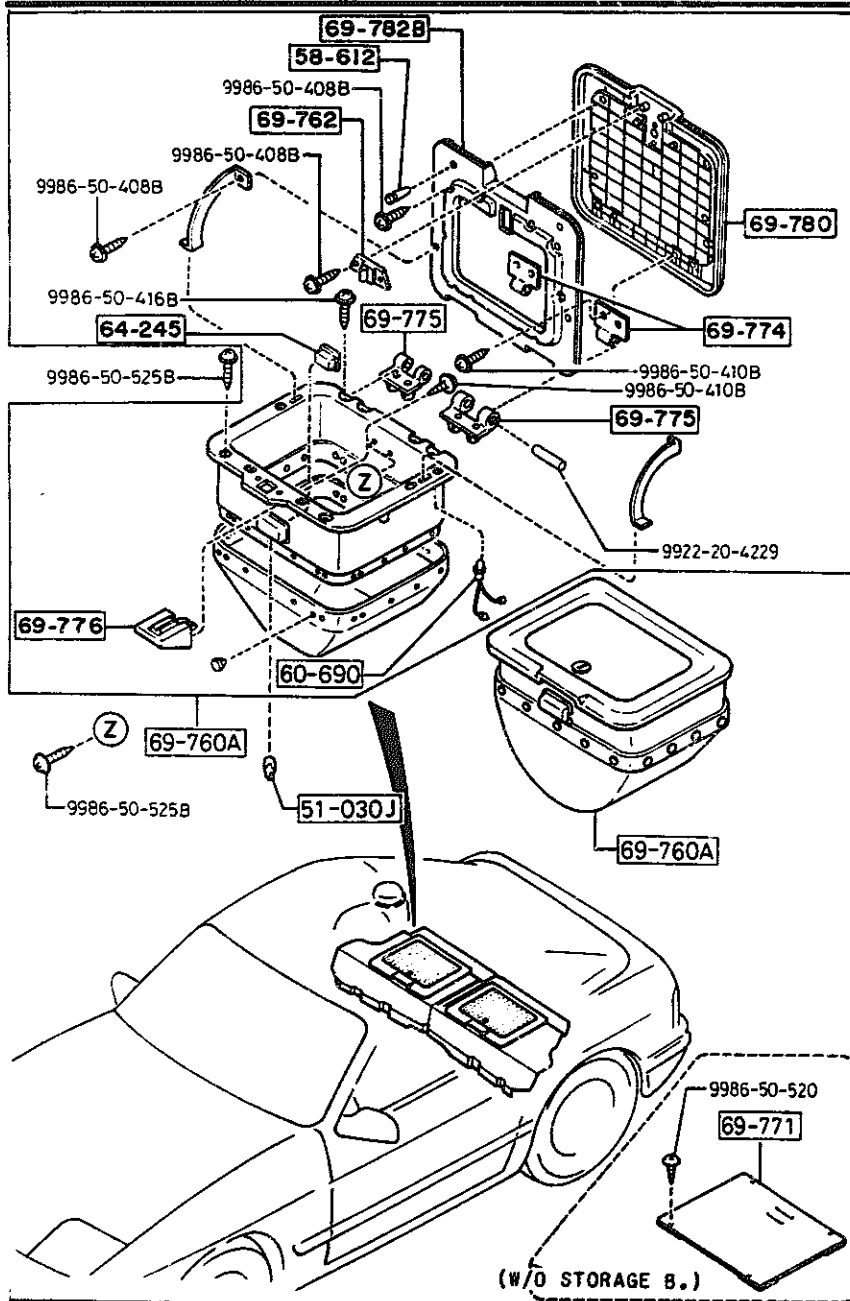

PART NO.	QTY	MODEL/RESTRICTION	MODEL/RESTRICTION	MODEL/RESTRICTION	FROM-TO
69-776		STRIKER, STORAGE BOX			
FB01-69-776	2				
69-780		LID, OUTER-STORAGE BOX			
FB01-69-780	2				
02		FD8 BLACK			
19		FEO RED			
48		FD9 BLUE			
69-782B		LID, INNER-STORAGE BOX			
FB01-69-782	2				
02		FD8 BLACK			
19		FEO RED			
48		FD9 BLUE			

FROM-TO

-9113

9113-

-9113

9113-

-9113

-9113

1992-05

AUFA02

CAT. AUFA02-06

1992-05

4-C11

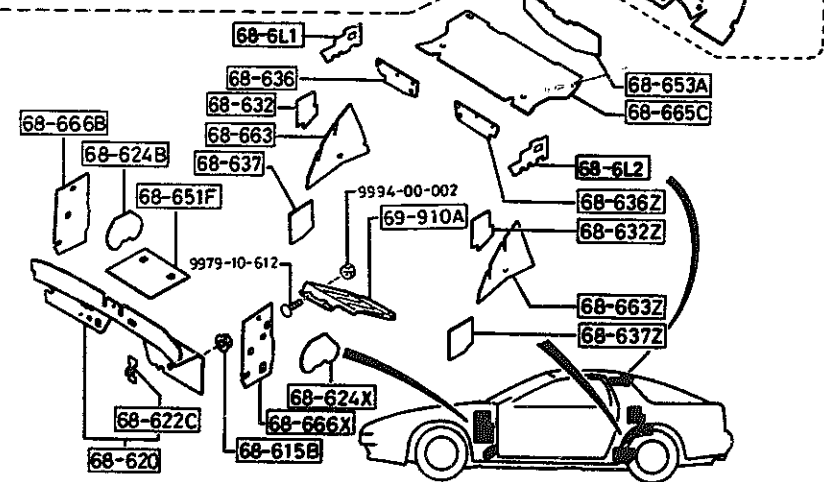
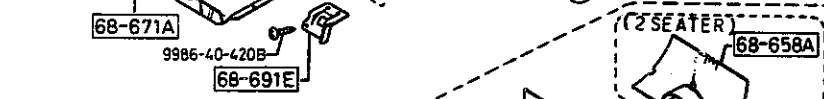
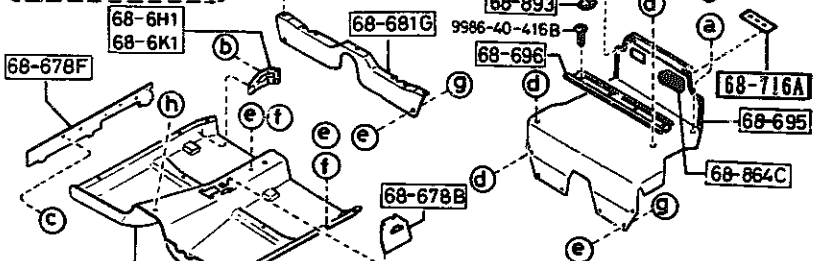
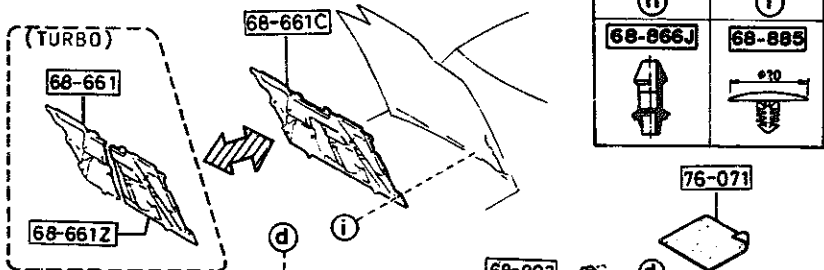
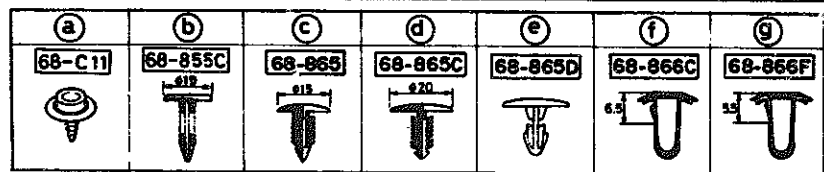

4-D11

PART NO.	QTY	MODEL/RESTRICTION	MODEL/RESTRICTION	MODEL/RESTRICTION	FROM-TO
68-C11		HOOK, SCREW-TRUNK MAT			
FC01-68-C11A A (FC01-68-C11B)	3				-9113
FC01-68-C11B	3	(2SEATER)			9113-
68-6H1		COVER(R), LAP BELT			
FC01-68-6H1A A (FC01-68-6H1B)	1				-9202
02		FD8 BLACK			
19		FE0 RED			
48		FD9 BLUE			
FC01-68-6H1B	1				9202-
02		FD8 FE1 BLACK			
19		FE0 RED			
48		FD9 BLUE			
68-6K1		COVER(L), LAP BELT			
FC01-68-6K1A A (FC01-68-6K1B)	1				-9202
02		FD8 BLACK			
19		FE0 RED			
48		FD9 BLUE			
FC01-68-6K1B	1				9202-
02		FD8 FE1 BLACK			
19		FE0 RED			
48		FD9 BLUE			
68-6L1		COVER 'A', HOLE			
FC01-68-6L1	1				
68-6L2		COVER 'B', HOLE			
FC01-68-6L2	1				
68-615B		NUT, FLANGE-CAP			
8100-68-615	13				
68-620		INSULATOR, DASHBOARD			
F802-68-62CA	1	GTU, GTUS, (W/O SILENCER PAD)			
9113 FC3MNR-70006*					
9202 FC3MNR-702073					

6860 FLOOR MATS & PADS (COUPE)

6860 -2 FLOOR MATS & PADS (COUPE)

(a) 68-C11	(b) 68-855C	(c) 68-865	(d) 68-865C	(e) 68-865D	(f) 68-866C	(g) 68-866F

(h) 68-866J	(i) 68-885

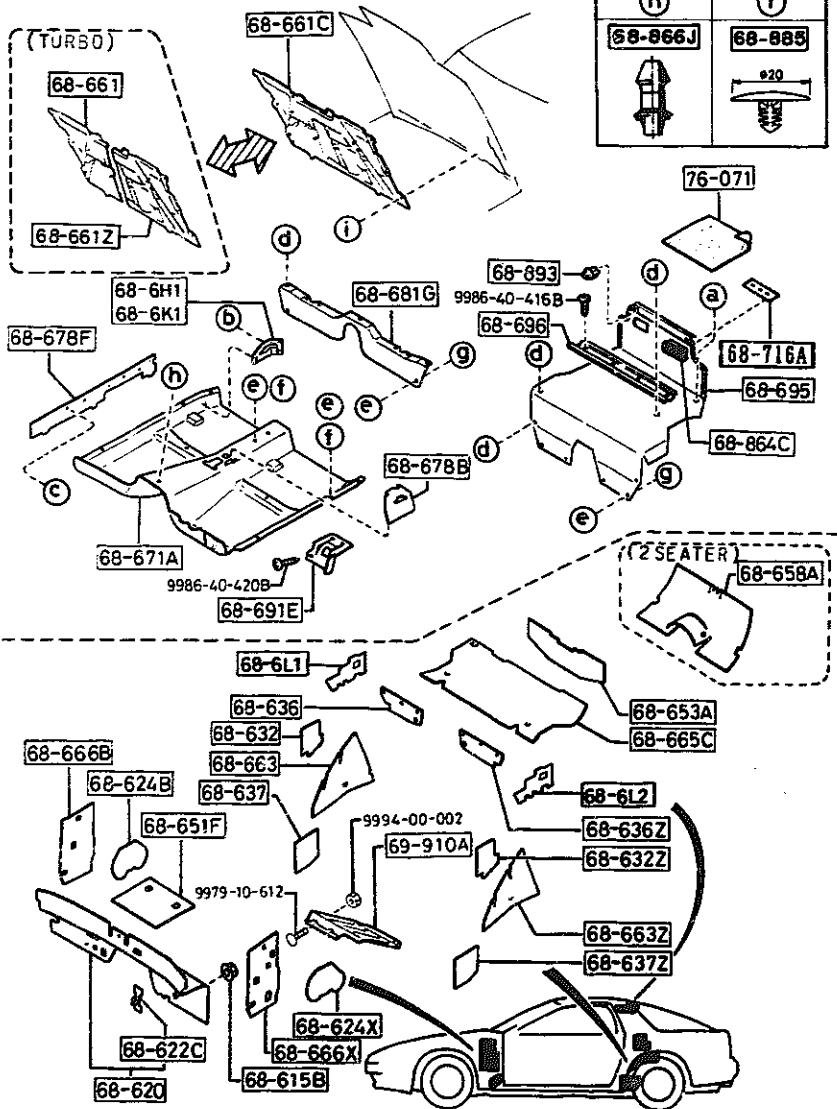

PART NO.	QTY	MODEL/RESTRICTION	MODEL/RESTRICTION	MODEL/RESTRICTION	FPGM-TO
CONT'D FB04-68-620A	1	GXL, TURBO, (W/SILENCER PAD)			
68-622C	4	CLIP,DASHBOARD INSUL ATOR			
FB01-68-622	4				
68-624B	1	COVER(R),HOLE-DASH. INSU.			
FB01-68-624	1				
68-624X	1	COVER(L),HOLE-DASH. INSU.			
FB01-68-625	1				
68-632	1	COVER(R),RETRACTOR			
FB01-68-632	1	(2SEATER)			
FB25-68-632	1	(4SEATER)			
68-632Z	1	COVER(L),RETRACTOR-R EAF			
FB01-68-642	1	(2SEATER)			
FB25-68-642	1	(4SEATER)			
68-636	1	INSULATOR(R),CROSS M EMBER			
FB01-68-636A	1				
68-636Z	1	INSULATOR(L),CROSS M EMBER			
FB01-68-646A	1				
68-637	1	COVER(R),RETRACTOR-F RONT			
FB01-68-637	1				
68-637Z	1	COVER(L),RETRACTOR-F RONT			
FB01-68-647	1				
68-651F	1	PAD,FRONT FLOOR			
FB01-68-652	1				
68-653A	1	INSULATOR,SPARE TIRE			
FB01-68-653	1				
68-658A	1	PAD,STRAGE BOX			
FB01-68-658	1	GTU, GTUS, (W/O SILENCER PAD) (2SEATER)			

AUFA02

CAT. AUFA02-06

4-E11

6860 FLOOR MATS & PADS
(COUPE)

6860 -3 FLOOR MATS & PADS
(COUPE)

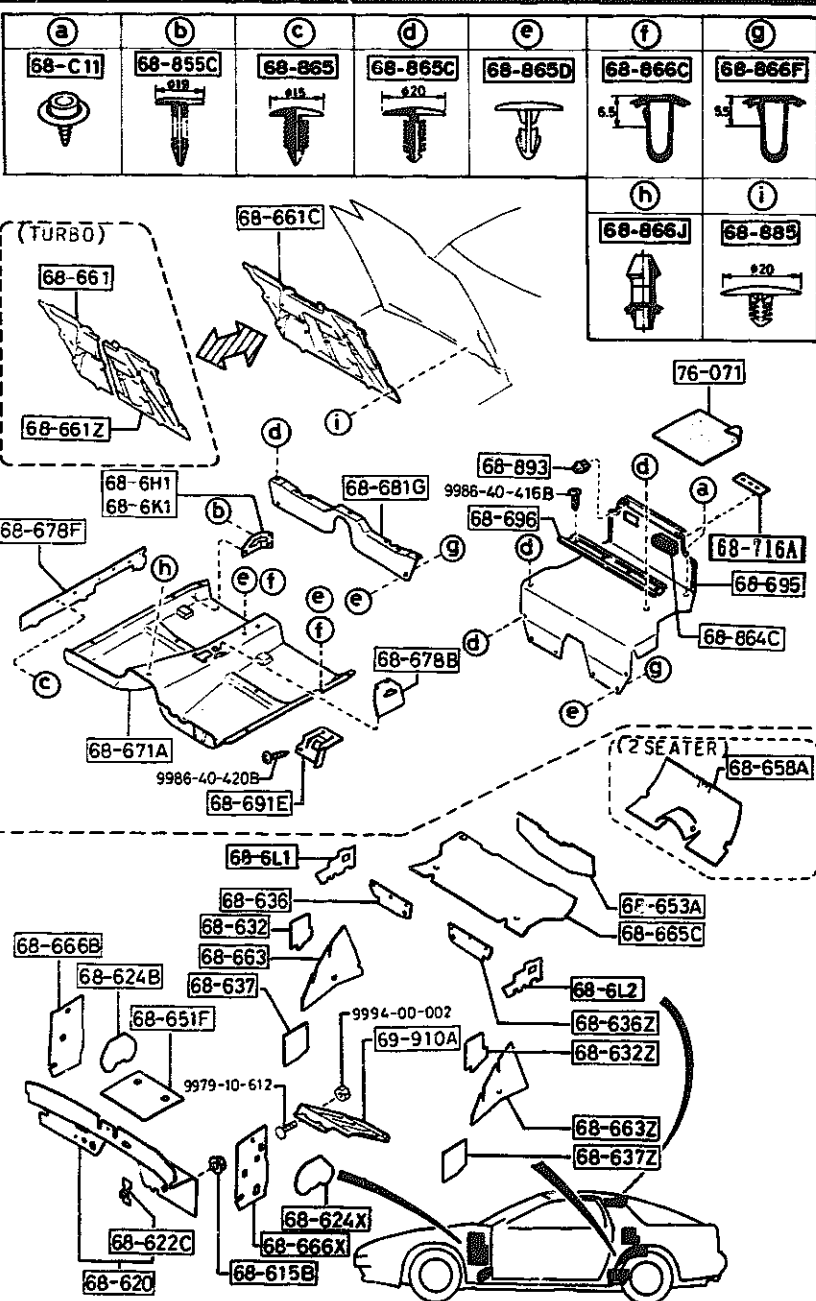

PART NO.	QTY	MODEL/RESTRICTION	MODEL/RESTRICTION	MODEL/RESTRICTION	FROM-TO
CONT'D					
FB03-68-658	1	GXL, TURBO, (W/SILENCER PAD) (2SEATER)			
68-661		INSULATOR(R), BONNET			
F046-68-661B	1	(TURBO)			
68-661C		INSULATOR, BONNET			
FB03-68-661A	1	(W/O TURBO)			
68-661Z		INSULATOR(L), BONNET			
F046-68-662A	1	(TURBO)			
68-663		INSULATOR(R), TIRE HO USE			
FB01-68-663	1	GTU, GTUS, (W/O SILENCER PAD)			
FB03-68-663	1	GXL, TURBO, (W/SILENCER PAD)			
68-663Z		INSULATOR(L), TIRE HO USE			
FB01-68-664	1	GTU, GTUS, (W/O SILENCER PAD)			
FB03-68-664	1	GXL, TURBO, (W/SILENCER PAD)			
68-665C		PAD, TRUNK			
FC01-68-814	1	GTU, GTUS, (W/O SILENCER PAD)			
FC02-68-814	1	GXL, TURBO, (W/SILENCER PAD)			
68-666B		PAD(R), SIDE-DASHBOAR D			
FB03-68-666A	1				
68-666X		PAD(L), SIDE-DASHBOAR D			
FB03-68-667A	1				
68-671A		MAT, FLOOR			
FC02-68-671 A (FC02-68-671A)	1				
02		FD8 BLACK			
19		FE0 RED			
48		FD9 BLUE			
9113 FC3MMX-700067					

-9113

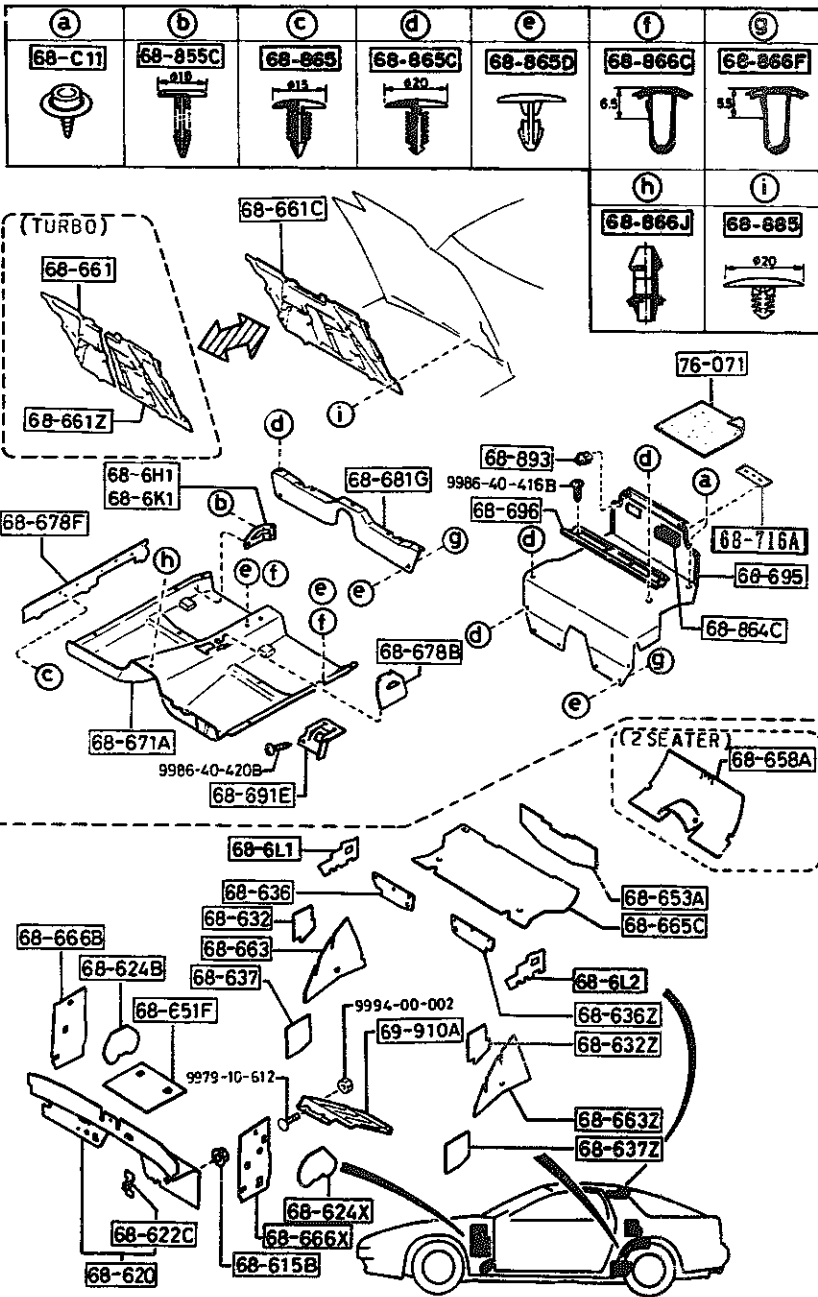

PART NO.	QTY	MODEL/RESTRICTION	MODEL/RESTRICTION	MODEL/RESTRICTION	FROM-TO
CONT'D					
FC04-68-671	1				-9113
A (FC04-68-671A)					
02		F08 BLACK			
19		F09 RED			
48		F09 BLUE			
FC02-68-671A	1	((W/O TURBO)>(W/O A. A. SUSP.))			9113-
02		F08 FE1 BLACK			
19		F09 RED			
48		F09 BLUE			
FC04-68-671A	1	((W/O TURBO)>(A.A. SUSP.)) (TURBO)			9113-
02		F08 FE1 BLACK			
19		F09 RED			
48		F09 BLUE			
68-678B		MAT, PARKING BRAKE			
FC02-68-679	1				
02		F08 FE1 BLACK			
19		F09 RED			
48		F09 BLUE			
68-678F		GUARD, HARNESS-FRONT			
FB67-68-678	2				
68-681G		MAT, END-TRUNK ROOM			
FB01-68-681B	1	GTUS, GXL, TURBO, (W/CARGO ROOM STRAP)			
		(4SEATER)			
02		F08 BLACK			
19		F09 RED			
48		F09 BLUE			
68-691E		COVER, OPENER-FLOOR MAT			
FB01-68-691D	1				
02		F08 FE1 BLACK			
19		F09 RED			
48		F09 BLUE			

9113 FC3333-70067

6860 FLOOR MATS & PADS
(COUPE)

6860 -5 FLOOR MATS & PADS
(COUPE)

FROM-TO

(a) 68-C11	(b) 68-855C	(c) 68-865	(d) 68-865C	(e) 68-865D	(f) 68-866C	(g) 68-866F
					(h) 68-866J	(i) 68-888

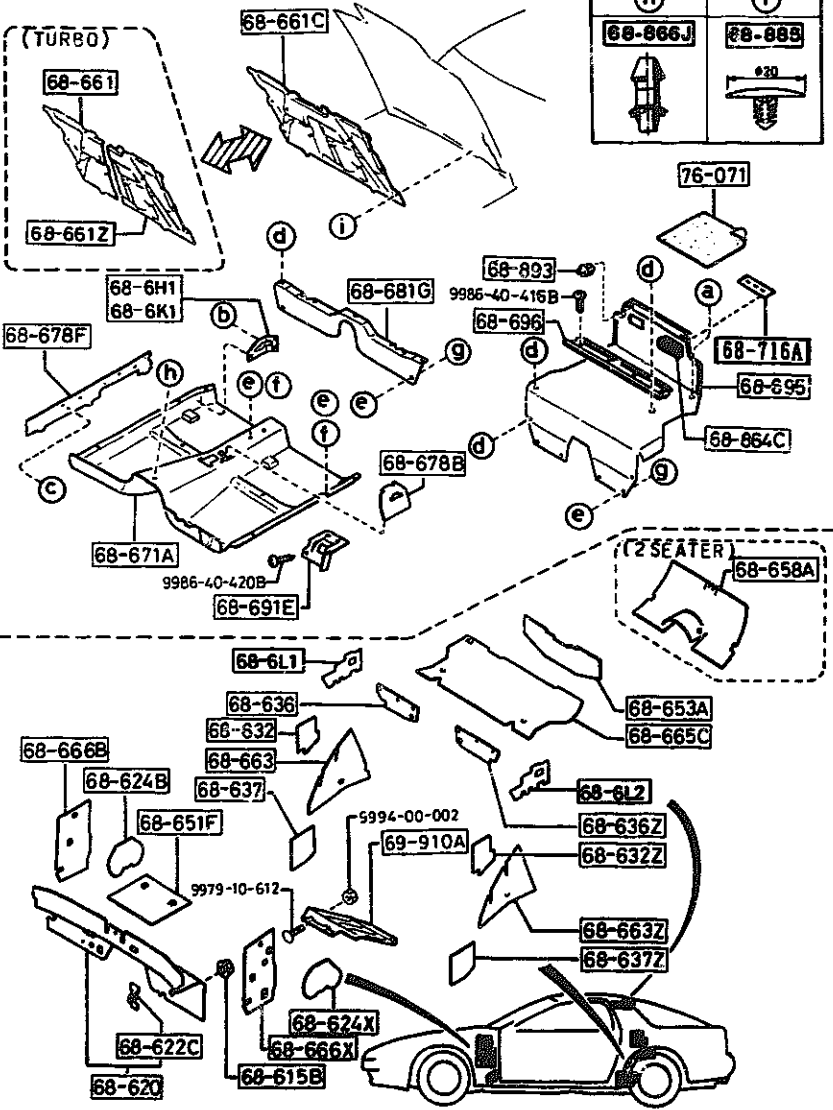

PART NO.	QTY	MODEL/RESTRICTION	MODEL/RESTRICTION	MODEL/RESTRICTION	FROM-TO
68-695		MAT, TRUNK ROOM			
FB09-68-69X	1	GTUS, GXL, TURBO, (W/CARGO ROOM STRAP) (4SEATER)			
02		FD8 BLACK			
19		FE0 RED			
48		FD9 BLUE			
FC02-68-81XA	1	GTU, (W/STORAGE B. W/O CA RGO STRAP W/O SILENC ER PAD) (2SEATER)			
02		FD8 BLACK			
19		FE0 RED			
48		FD9 BLUE			
FC04-68-81XA	1	GXL, TURBO, (W/STORAGE B. W/CARG O STRAP W/SILENCER P AD) (2SEATER)			
02		FD8 BLACK			
19		FE0 RED			
48		FD9 BLUE			
FC05-68-81XA	1	GTUS, (W/STORAGE B. W/CARG O STRAP W/O SILENCER PAD) (2SEATER)			
02		FD8 BLACK			
19		FE0 RED			
48		FD9 BLUE			
FC06-68-81XA	1	GXL, (W/O STRAGE B. W/O C ARGO STRAP W/SILENCE R PAD) (2SEATER)			
02		FD8 BLACK			
19		FE0 RED			
48		FD9 BLUE			
68-696		PLATE, MAT SET			
FB09-68-696A	1	(4SEATER)			
02		FD8 FD8 FE1 BLACK			









1992-05

AUFA02

CAT. AUFA02-06

1992-05

4 H11

(a) 68-C11 	(b) 68-855C 	(c) 68-885 	(d) 68-865C 	(e) 68-863D 	(f) 68-866C 	(g) 68-863F 
(h) 68-866J 	(i) 68-865 					

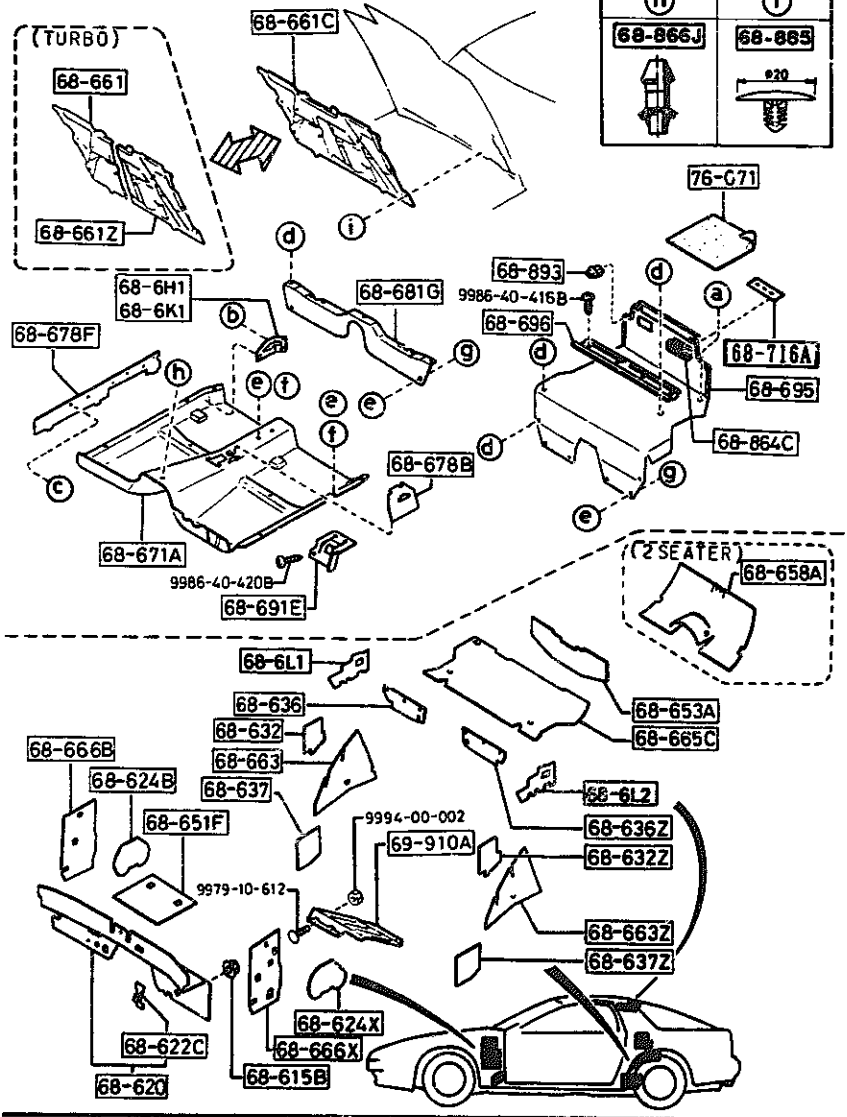

PART NO.	QTY	MODEL/RESTRICTION	MODEL/RESTRICTION	MODEL/RESTRICTION	FROM-TO
CONT'D					
19		FEO FE0 RED			
48		FD9 FD9 BLUE			
68-716A		NUT, SPEED			
F803-68-862	2				
68-855C		FASTENER			
G043-68-865B	2				
00		FE1 BLACK			
19		FE0 RED			
48		FD9 BLUE			
68-864C		GRILLE, EXTRACT.-T.S. TRIM FOR TEMPORARY TIRE			
FB01-68-864	2				
02		FDB FE1 BLACK			
19		FE0 RED			
48		FD9 BLUE			
68-865		FASTENER			
B003-68-865	11				
65		FEO FD8 FD9 FE1 OFF-BLACK			
68-865C		FASTENER			
G032-68-865A	14				
00		FDB FE1 BLACK			
68-865D		FASTENER			
S083-68-865A	7				-9A01
00		FDB FE1 BLACK			
S063-68-865A	5				9A01-
00		FDB FE1 BLACK			
68-866C		FASTENER, SEAL			
B235-68-865A	7				-9A01
B235-68-865A	5				9A01-
68-866F		FASTENER, SEAL			

9A01 FC3MM-803554

6860 FLOOR MATS & PADS (COUPE)

6860 -7 * FLOOR MATS & PADS (COUPE)

(a) 68-C11	(b) 68-855C	(c) 68-865	(d) 68-865C	(e) 69-865C	(f) 68-866C	(g) 68-866F

(h) 68-866J	(i) 68-885

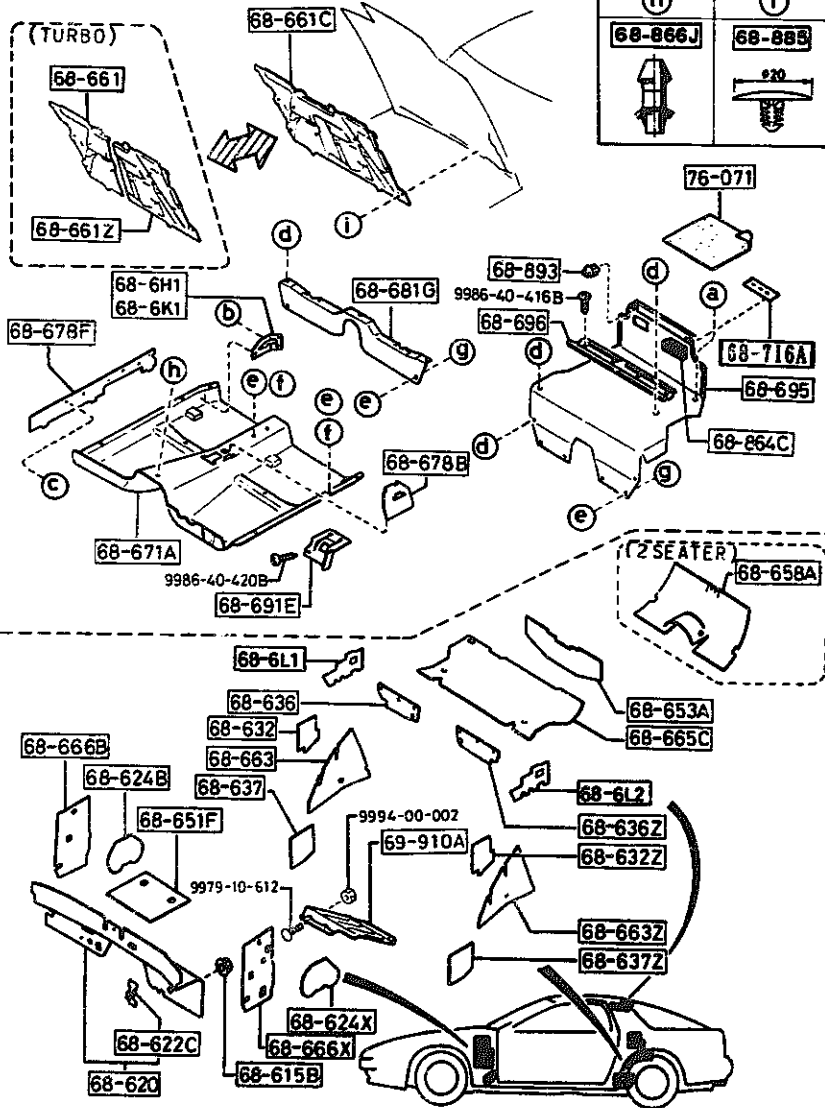

PART NO.	QTY	MODEL/RESTRICTION	MODEL/RESTRICTION	MODEL/RESTRICTION	FROM-TO
CONT'D					
G031-68-866B	4				
68-866J		FASTENER, SEAL			
FB01-68-866	1				
68-885		FASTENER			
G030-68-885B	16				
00		FD8 FD9 FE0 FD8 FD9 FE0 FE1 FD8 FD9 FE1 BLACK			
68-893		LATCH, TRUNK END TRIM			
FB01-68-893	2				
02		FD8 FE1 BLACK			
19		FE0 RED			
48		FD9 BLUE			
69-910A		SUPPORT, FOOT			
FB01-69-910A	1				
76-071		SILENCER, FLOOR			
0208-76-071	1	30CMX30CM			

AUFA02

CAT. AUFA02-06

1992-05

4-J11

6860A FLOOR MATS & PADS
(CONVERTIBLE)

6860A -1 FLOOR MATS & PADS
(CONVERTIBLE)

FROM-TO

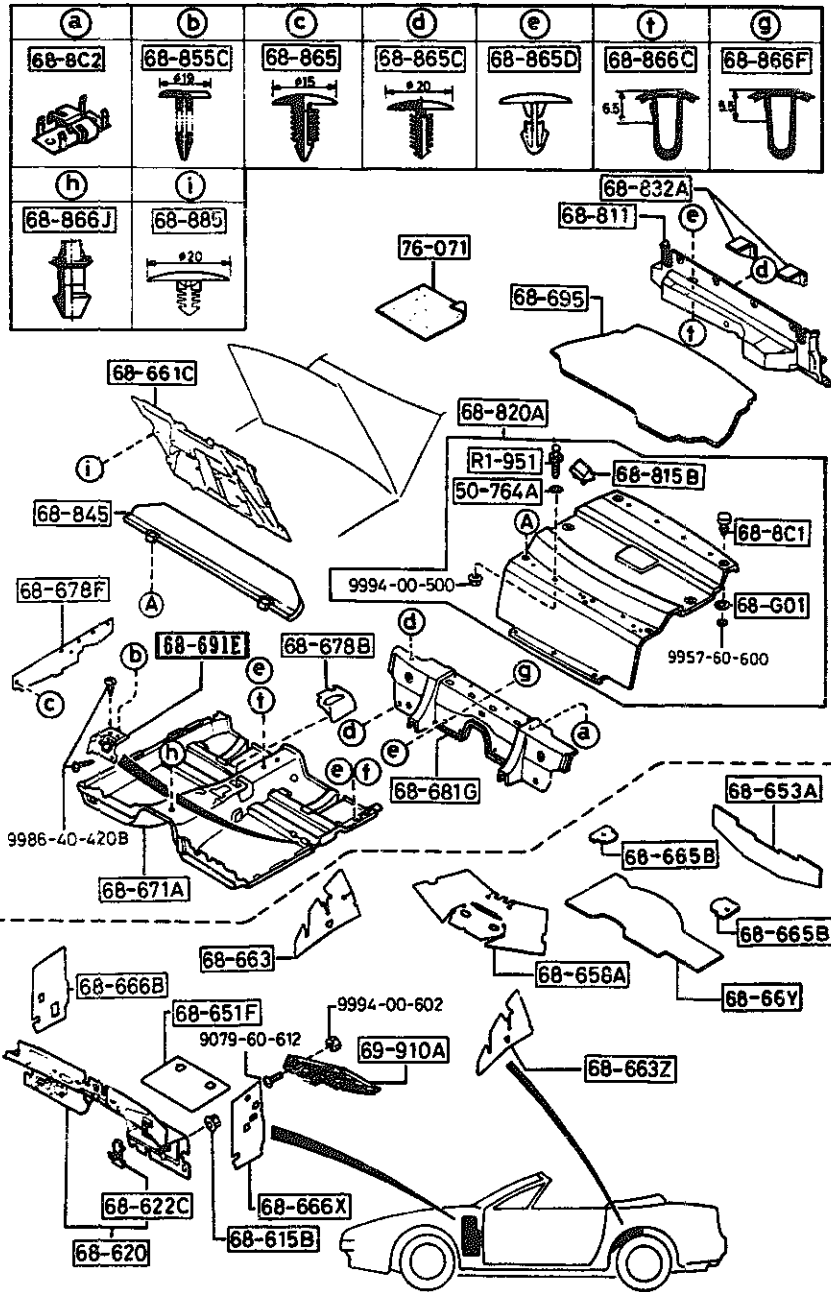

PART NO.	QTY	MODEL/RESTRICTION	MODEL/RESTRICTION	MODEL/RESTRICTION	FROM-TO
R1-951		HOOK 'A', HOOD COVER-REAR			
B235-R1-951C	2				
50-764A		WASHER, COVER-SPARE TIRE			
FB67-50-764A	2				
68-001		WASHER, SPARE TIRE COVER			
FB67-68-001	6				
68-615B		NUT, FLANGE-CAP			
B100-68-615	11				
68-620		INSULATOR, DASHBOARD			
FB67-68-620	1				
68-622C		CLIP, DASHBOARD INSULATOR			
FB01-68-622	4				
68-651F		PAD, FRONT FLOOR			
FB01-68-652	1				
68-653A		INSULATOR, SPARE TIRE			
FB01-68-653	1				
68-658A		PAD, STRAGE BOX			
FB67-68-658A	1				
68-66Y		PAD, FLOOR-REAR			
FB67-68-66Y	1				
68-661C		INSULATOR, BONNET			
FB03-68-661A	1				
68-663		INSULATOR(R), TIRE HO USE			
FB01-68-663	1				
68-663Z		INSULATOR(L), TIRE HO USE			
FB01-68-664	1				
68-65B		PAD, SUSPENSION			
FB67-68-665	2				

1992-05

AUFA02

CAT. AUFA02-06

1992-05

4-K11

6860A FLOOR MATS & PADS (CONVERTIBLE)

6860A -2 FLOOR MATS & PADS (CONVERTIBLE)

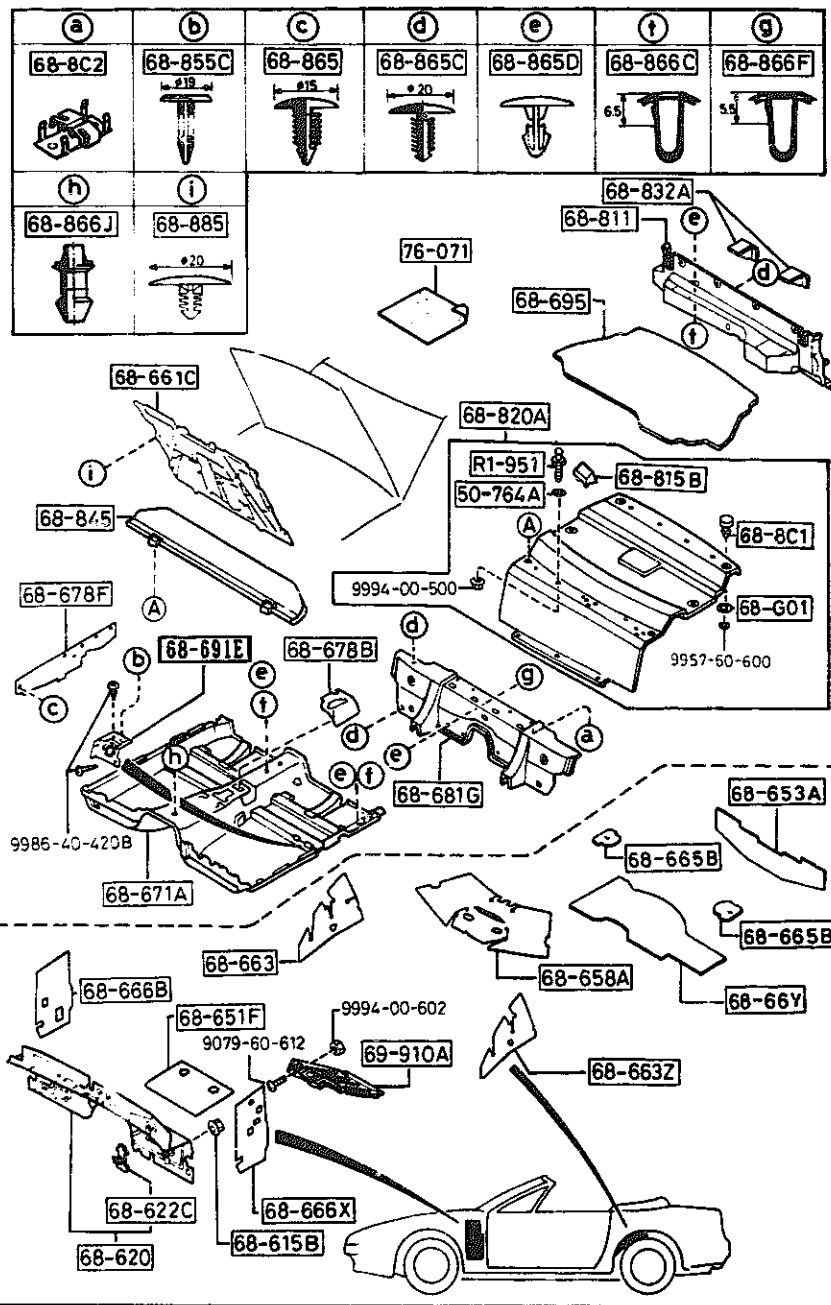

PART NO.	QTY	MODEL/RESTRICTION	MODEL/RESTRICTION	MODEL/RESTRICTION	FROM-TO
68-666B		PAD(R),SIDE-DASHBOAR D			
FB03-68-666A	1				
68-666X		PAD(L),SIDE-DASHBOAR D			
FB03-68-667A	1				
68-671A		MAT,FLOOR			
FB67-68-671B	1	(W/O AIR BAG)			
02		FD8 BLACK			
48		FD9 BLUE			
FC66-68-671	1	(W/AIR BAG)			
02		FD8 BLACK			
48		FD9 BLUE			
68-678B		MAT,PARKING BRAKE			
FB67-68-673	1				
02		FD8 FE1 BLACK			
19		FE0 RED			
48		FD9 BLUE			
68-678F		GUARD,HARNES-FRONT			
FB67-68-678	2				
68-681G		MAT,END-TRUNK ROOM			
FB67-68-681	1				
A (FB67-68-681A)					
02		FD8 BLACK			
48		FD9 BLUE			
FB67-68-681A	1				
02		FD8 FE1 BLACK			
48		FD9 BLUE			
68-691E		COVER,OPENER-FLOOR M AT			
FB01-68-691D	1				
02		FD8 FE1 BLACK			
48		FD9 BLUE			
68-695		MAT,TRUNK ROOM			
9101 FC3***-700067					

6860A FLOOR MATS & PADS
(CONVERTIBLE)

6860A -3 FLOOR MATS & PADS
(CONVERTIBLE)

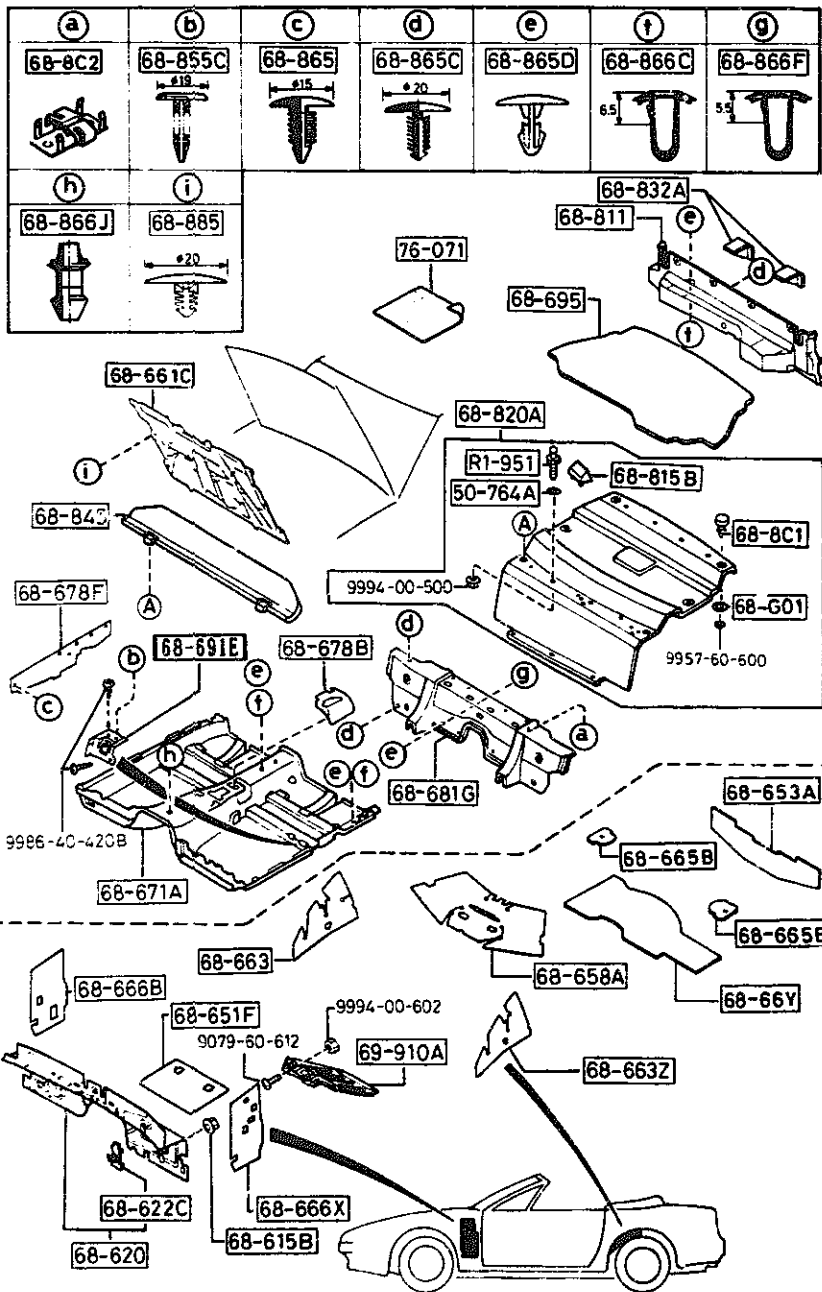

PART NO.	QTY	MODEL/RESTRICTION	MODEL/RESTRICTION	MODEL/RESTRICTION	FROM-TO
CONT'D					
FB67-68-831B	1				
07		FD8 FD9 FE1 GRAY/DARK GRAY			
68-8C1		FASTENER, TAPPING			
FB67-68-8C1	6				
02		FD8 FE1 BLACK			
48		FD9 BLUE			
68-8C2		NUT, EXPANSION			
FB67-68-8C2	2				
68-811		BOARD, PARTITION			
FC33-68-82X A (FC33-68-82XA)	1				-9801
07		FD8 FD9 DARK GRAY			
FC33-68-82XA	1				9801-
07		FD8 FD9 FE1 DARK GRAY			
68-815B		RUBBER, CUSHION			
FB67-68-815	2				
68-820A		COVER, SPARE TIRE			
FB67-68-810D	1				
02		FD8 FE1 BLACK			
48		FD9 BLUE			
68-832A		BRACKET, TRUNK BOARD			
FB67-68-832	2				
68-845		BLOCKER, WIND			
FB67-68-845	1				
02		FD8 FE1 BLACK			
48		FD9 BLUE			
68-855C		FASTENER			
G043-68-865B	1				
00		FD8 FD8 FD9 FE0 FE1 BLACK			

9801 FC33MM-804224

6860A FLOOR MATS & PADS
(CONVERTIBLE)

6860A -4 * FLOOR MATS & PADS
(CONVERTIBLE)

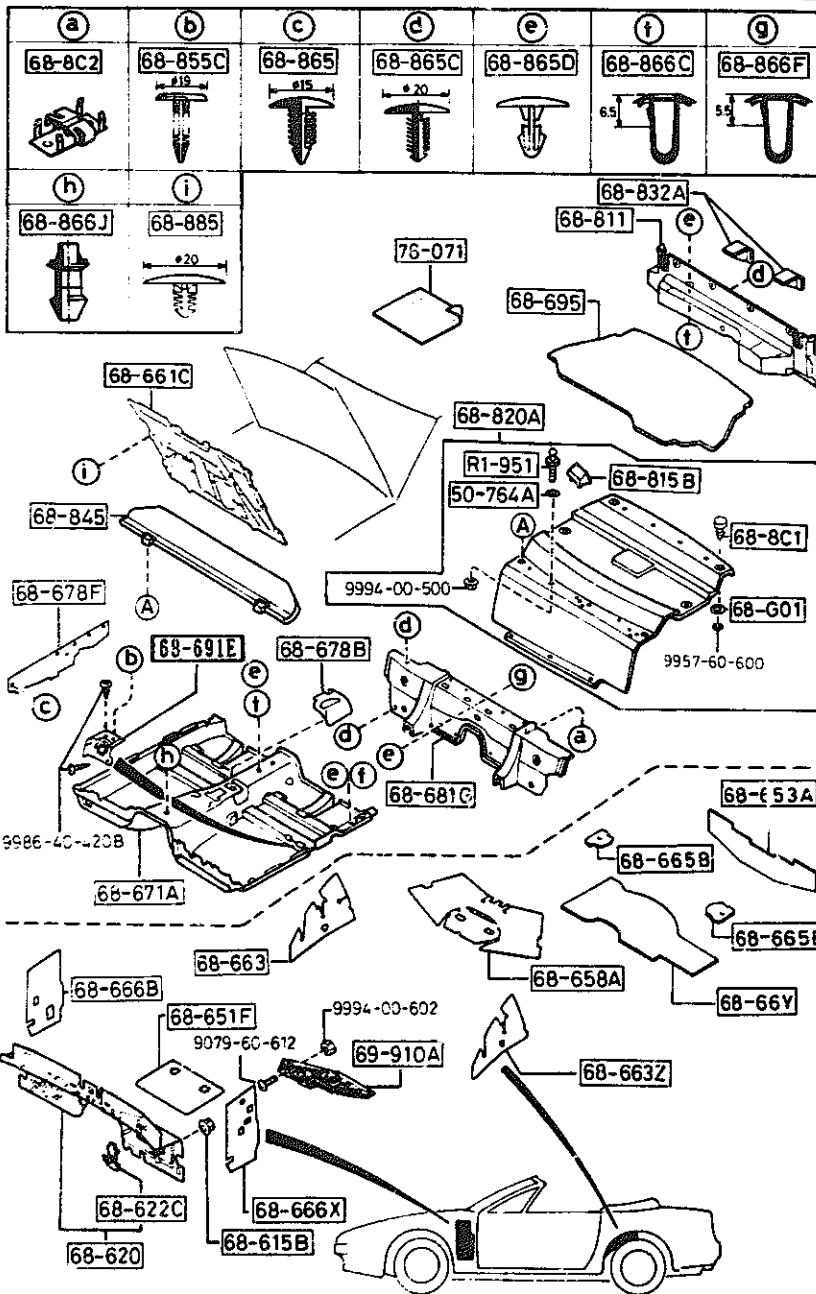

PART NO.	QTY	MODEL/RESTRICTION	MODEL/RESTRICTION	MODEL/RESTRICTION	FROM-TO
68-865		FASTENER			
8003-68-865	11				
65		FD8 FD9 FE0 FD8 FD9 FE0 FE1 FD8 FD9 FE1 OFF-BLACK			
68-865C		FASTENER			
G032-68-865A	17				
00		FD8 FE1 BLACK			
48		FD9 BLUE			
68-865D		FASTENER			
S083-68-865A	11				
00		FD8 FE1 BLACK			
48		FD9 BLUE			
68-866C		FASTENER, SEAL			
B235-68-865A	9				
68-866F		FASTENER, SEAL			
G031-68-866B	2				
68-866J		FASTENER, SEAL			
FB01-68-866	1				
68-885		FASTENER			
G030-68-885B	16				
00		FD8 FD9 FE0 FD8 FD9 FE0 FE1 FD8 FD9 FE1 BLACK			
69-910A		SUPPORT, FOOT			
FB01-69-697A	1				
76-071		SILENCER, FLOOR			
0208-76-071	1	30CMX30CM			

AUFA02

CAT. AUFA02-06

1992-05

4-N11

SECTION NAME INDEX (BODY) 2/2

LD.NO	SEC.NO	SECTION NAME	LD.NO	SEC.NO	SECTION NAME	LD.NO	SEC.NO	SECTION NAME
4-C03	6100	HEATER	4-E08	6703	WIRING HARNESSSES(DOOR,FLOOR/CEILING)			
4-E03	6110	HEATER UNIT COMPONENTS	4-G08	6704	WIRING HARNESS CLAMPS			
4-F03	6115	HEATER CONTROLS COMPONENTS	4-J08	6720	WINDSHIELD WASHER (1.5L & 2.5L)			
4-G03	6120	HEATER BLOWER COMPONENTS	4-L08	6720 A	WINDSHIELD WASHER (5.7L)			
4-I03	6130	AIR CONDITIONER	4-N08	6730	WINDSHIELD WIPERS			
4-J03	6230	LIFT GATE MECHANISMS (COUPE)	4-C09	6740	WIPER MOTOR COMPONENTS(FRONT)			
4-M03	6300	WINDOW GLASSES (COUPE)	4-D09	6750	WINDOW WIPER & WASHER (REAR)			
4-N03	6300A	WINDOW GLASSES (CONVERTIBLE)	4-G09	6760	WINDOW WIPER MOTOR COMPONENTS (REAR)			
4-C04	6330	SUNROOF (COUPE)	4-H09	6800	CEILING TRIMS (COUPE)			
4-G04	6330A	SUNROOF (CONVERTIBLE)	4-J09	6800A	CEILING TRIMS (CONVERTIBLE)			
4-M04	6600	SWITCHES & RELAYS (ENGINE)	4-K09	6810	ROLLEBAR (CONVERTIBLE)			
4-G05	6610	DASHBOARD SWITCHES	4-N09	6820	PILLAR TRIMS (COUPE)			
4-H05	6611	COMBINATION SWITCH	4-F10	6820A	PILLAR TRIMS (CONVERTIBLE)			
4-I05	6612	CLUSTER SWITCH	4-G10	6840	TRIMS & SCUFF PLATES (COUPE)			
4-L05	6615	POWER WINDOW SWITCHES	4-L10	6840A	TRIMS & SCUFF PLATES (CONVERTIBLE)			
4-M05	6630	RELAYS & UNIT (BODY)	4-N10	6845	STORAGE BOX (COUPE)			
4-D06	6635	DOOR SWITCH & HORNS			(GXL,TURBO)			
4-E06	6640	AUTO CRUISE CONTROL SYSTEM	4-D11	6860	FLOOR MATS & PADS (COUPE)			
4-F06	6680	AUDIO SYSTEMS (RADIO & TAPE DECK) (COUPE)	4-K11	6860A	FLOOR MATS & PADS (CONVERTIBLE)			
4-K06	6680 A	AUDIO SYSTEMS (RADIO & TAPE DECK) (CONVERTIBLE)	4-C12	6870	SERVICE TOOLS			
4-M06	6682	AUDIO SYSTEMS (ANTENNA & SPEAKER) (COUPE)	4-D12	6900	VISORS,ASSIST HANDLES & MIRRORS (COUPE)			
4-D07	6682 A	AUDIO SYSTEMS (ANTENNA & SPEAKER) (CONVERTIBLE)	4-H12	6900A	VISORS,ASSIST HANDLES & MIRRORS (CONVERTIBLE)			
4-G07	6684	AUDIO SYSTEMS(NOISE SUPPRESSOR & EARTH CORD)	4-K12	6930	CAUTION PLATES & LABELS			
4-H07	6700	WIRING HARNESSSES(FRONT & REAR)	4-N12	7250	QUARTER WINDOW & TRIMS			
4-N07	6701	WIRING HARNESSSES(ENGINE & TRANSMISSION)	4-E13	7800	SPOILERS & RELATED PARTS			
4-D08	6702	WIRING HARNESSSES(DASHBOARD)	4-C14	7900	ACCESSORIES			



6870 SERVICE TOOLS

6870 -1 * SERVICE TOOLS

FROM-TO

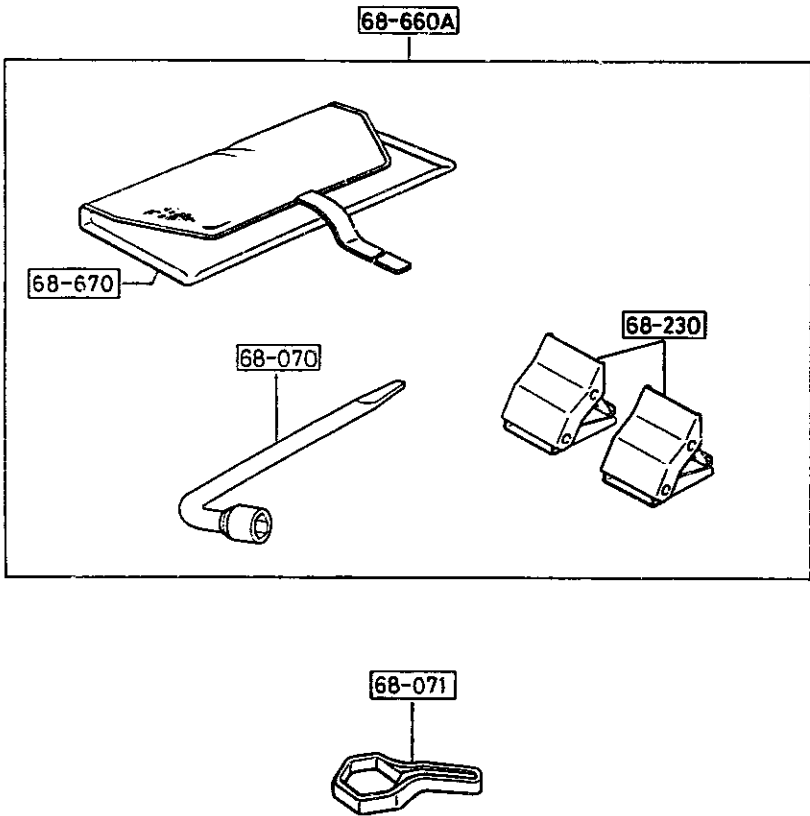

PART NO.	QTY	MODEL/RESTRICTION	MODEL/RESTRICTION	MODEL/RESTRICTION	FROM-TO
68-070		WRENCH,HUB NUT			
0810-68-070C A (0810-68-070E)	1				-9601
0810-68-070E	1				9601-
68-071		WRENCH,WHEEL CAP			
F057-68-071	1	(CONVERTIBLE)			
68-230		STOPPER,WHEEL			
0208-68-230	2				
68-660A		TOOL SET			
F801-69-650A	1				
68-670		BAG,TOOL			
F801-69-670A	1				

9601 FC3MM-708021

1992-05

AUFA02

CAT. AUFA02-06

1992-05

6900 VISORS, ASSIST HANDLES & MIRRORS
(COUPE)

6900 -1 VISORS, ASSIST HANDLES & MIRRORS
(COUPE)

FROM-TO
-9113
9113-
-9202
9202-
-9202
9202-
1992-05

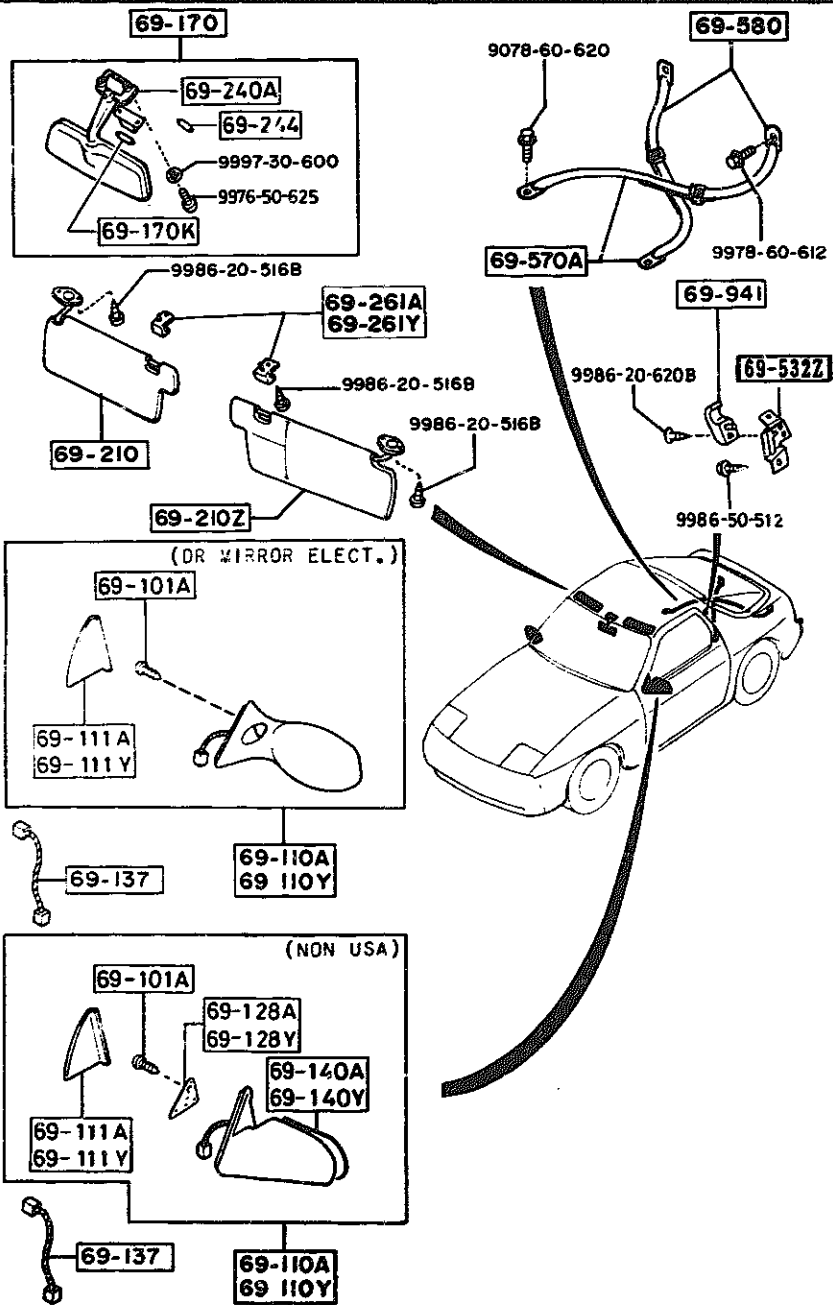

PART NO.	QTY	MODEL/RESTRICTION#	MODEL/PESTRICITION	MODEL/RESTRICTION	FROM-TO
69-110A		SCREW, DOOR MIRROR			
G032-69-12S	6	ICHIKO			
69-110A		MIRROR(R), DOOR			
FB11-69-110D	1	NON USA,			
FC01-69-110	1	USA, (DR MIRROR ELECT.)			
PZ		PZ BRILLIANT BLACK			
SQ		SQ BLAZE RED			
UC		UC CRYSTAL WHITE			
WY		WY NOBLE WHITE			
1F		1F WINNING SILVER M.			
3G		3G SHADOW SILVER METALL			
5D		5D HARBOR BLUE M.			
6H		6H MELLOW BURGUNDY MC			
69-110Y		MIRROR(L), DOOR			
FB11-69-170D	1	NON USA,			
FC01-69-170	1	USA, (DR MIRROR ELECT.)			
PZ		PZ BRILLIANT BLACK			
SQ		SQ BLAZE RED			
UC		UC CRYSTAL WHITE			
WY		WY NOBLE WHITE			
1F		1F WINNING SILVER M.			
3G		3G SHADOW SILVER METALL			
5D		5D HARBOR BLUE M.			
6H		6H MELLOW BURGUNDY MC			
69-111A		GARNISH(R), SAIL-IN.			
F045-69-112A	1				
69-111Y		GARNISH(L), SAIL-IN.			
F045-69-172A	1				

AUFA02

CAT. AUFA02-06

1992-05

4-D12

6900 VISORS, ASSIST HANDLES & MIRRORS (COUPE)

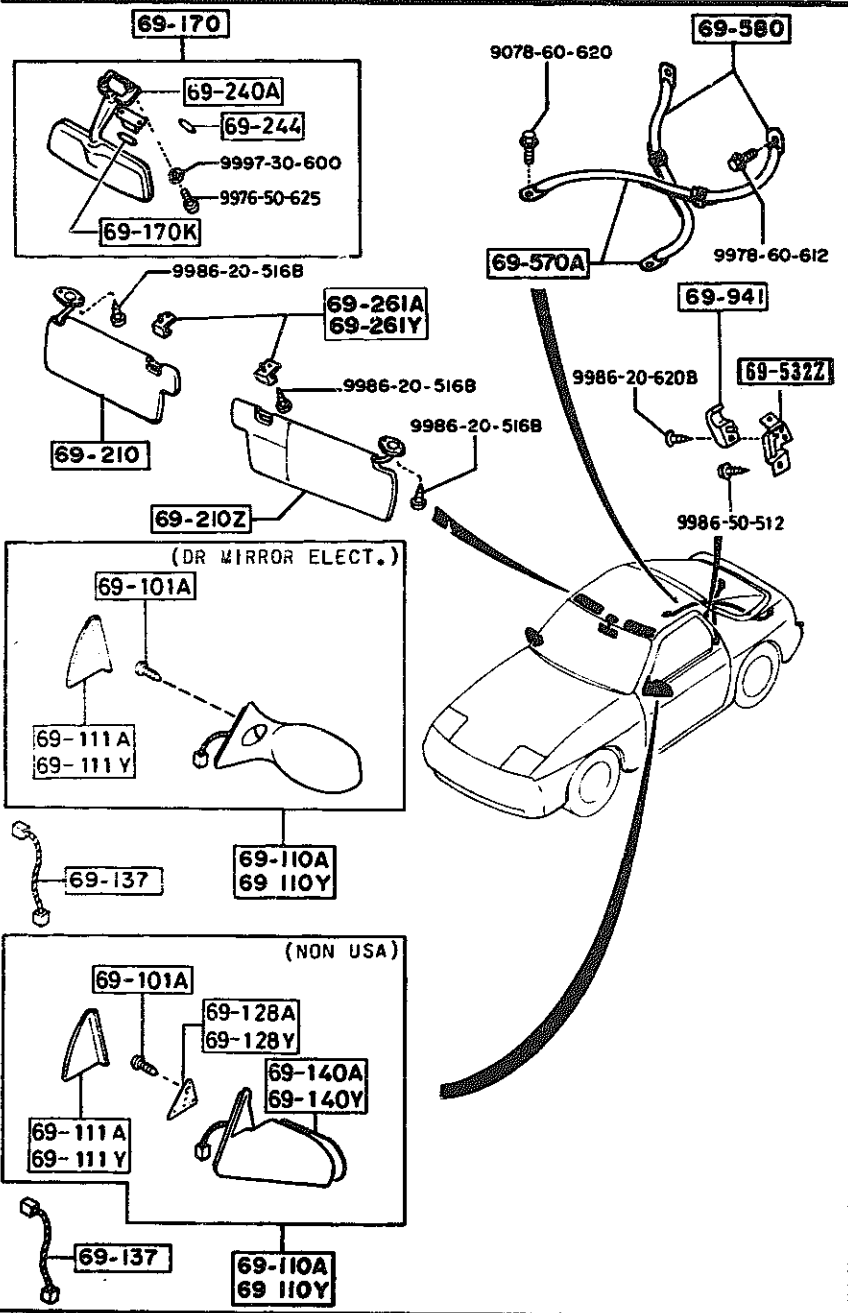

AUFA02

6900 -2 VISORS, ASSIST HANDLES & MIRRORS (COUPE)

PART NO.	QTY	MODEL/RESTRICTION	MODEL/RESTRICTION	MODEL/RESTRICTION	FROM-TO
69-128A		BOOT(R), DOOR MIRROR			
FB01-69-128	1	NON USA,			
69-128Y		BOOT(L), DOOR MIRROR			
FB01-69-188	1	NON USA,			
69-137		WIRE, REMOCON. MIRROR			
F045-69-108A	2				
69-140A		GLASS(R), MIRROR			
FB01-69-123	1	NON USA,			
69-140Y		GLASS(L), MIRROR			
FB01-69-183	1	NON USA,			
69-170		MIRROR, INTERIOR			
FB35-69-220F	1				
00		FD8 FD9 FE0 FD8 FD9 BLACK			
69-170K		BULB, INTERIOR MIRROR			
99700-5100	1	12V 10W			
69-210		SUN VISOR(R)			
FC02-69-270	1	(W/O SUN-RF)			
02		FD8 BLACK			
19		FE0 RED			
48		FD9 BLUE			
FC04-69-270	1	(SUNROOF)			
02		FD8 BLACK			
19		FE0 RED			
48		FD9 BLUE			
69-210Z		SUN VISOR(L)			
FC01-69-320	1	(W/O SUN-RF)			
02		FD8 BLACK			
19		FE0 RED			
48		FD9 BLUE			

CAT. AUFA02-06

4 E12

6900 VISORS, ASSIST HANDLES & MIRRORS (COUPE)

6900 -3 VISORS, ASSIST HANDLES & MIRRORS (COUPE)

FROM-TO

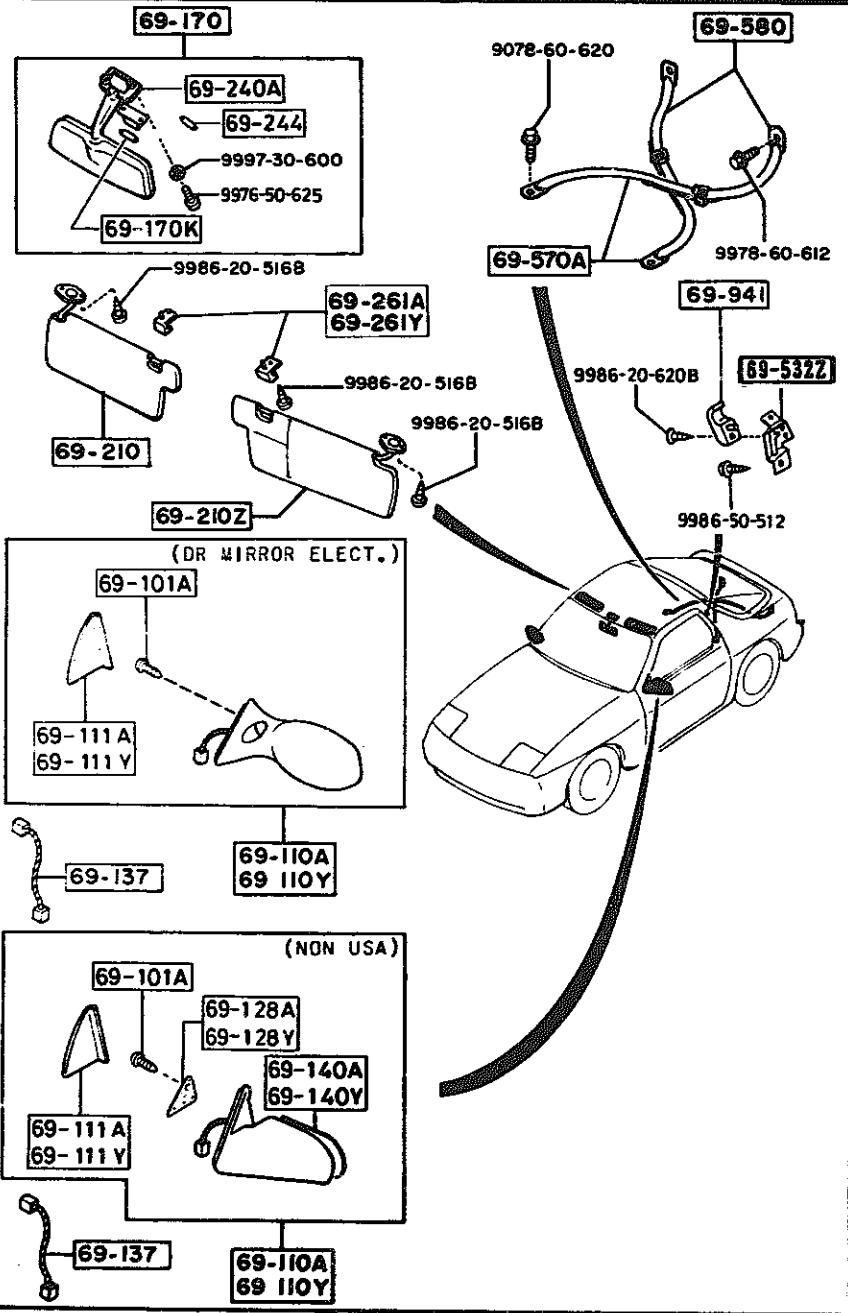

PART NO.	QTY	MODEL/RESTRICTION	MODEL/RESTRICTION	MODEL/RESTRICTION	FROM-TO
CONT'D					
FC03-69-320	1	(SUNROOF)			
02		FD8 BLACK			
19		FE0 RED			
48		FD9 BLUE			
69-240A		BASE, INTERIOR MIRROR			
FB10-69-240	1				
69-244		PIN, INTERIOR MIRROR			
FB10-69-244	2				
69-261A		ADAPTER(R), CTR-SUN V ISOR			
FB01-69-261	1	(W/O SUN-RF)			
02		FD8 FE1 BLACK			
19		FE0 RED			
48		FD9 BLUE			
FB03-69-261	1	(SUNROOF)			
02		FD8 FE1 BLACK			
19		FE0 RED			
48		FD9 BLUE			
69-261Y		ADAPTER(L), CTR-SUN V ISOR			
FB01-69-262	1	(W/O SUN-RF)			
02		FD8 FE1 BLACK			
19		FE0 RED			
48		FD9 BLUE			
FB03-69-262	1	(SUNROOF)			
02		FD8 FE1 BLACK			
19		FE0 RED			
48		FD9 BLUE			
69-532Z		BRKT(L), COAT HANGER			
FC01-69-542	1				
69-570A		STRAP'A', CARGOROOM			
FA54-69-571	2	GTUS, GXL, TURBO, (W/CARGO ROOM STRAP)			

-9113

1992-05

AUFA02

CAT. AUFA02-0

1992-05

4-F12

FROM-TO

-9113

9113-

9113-

1992-05

6900 VISORS, ASSIST HANDLES & MIRRORS (COUPE)

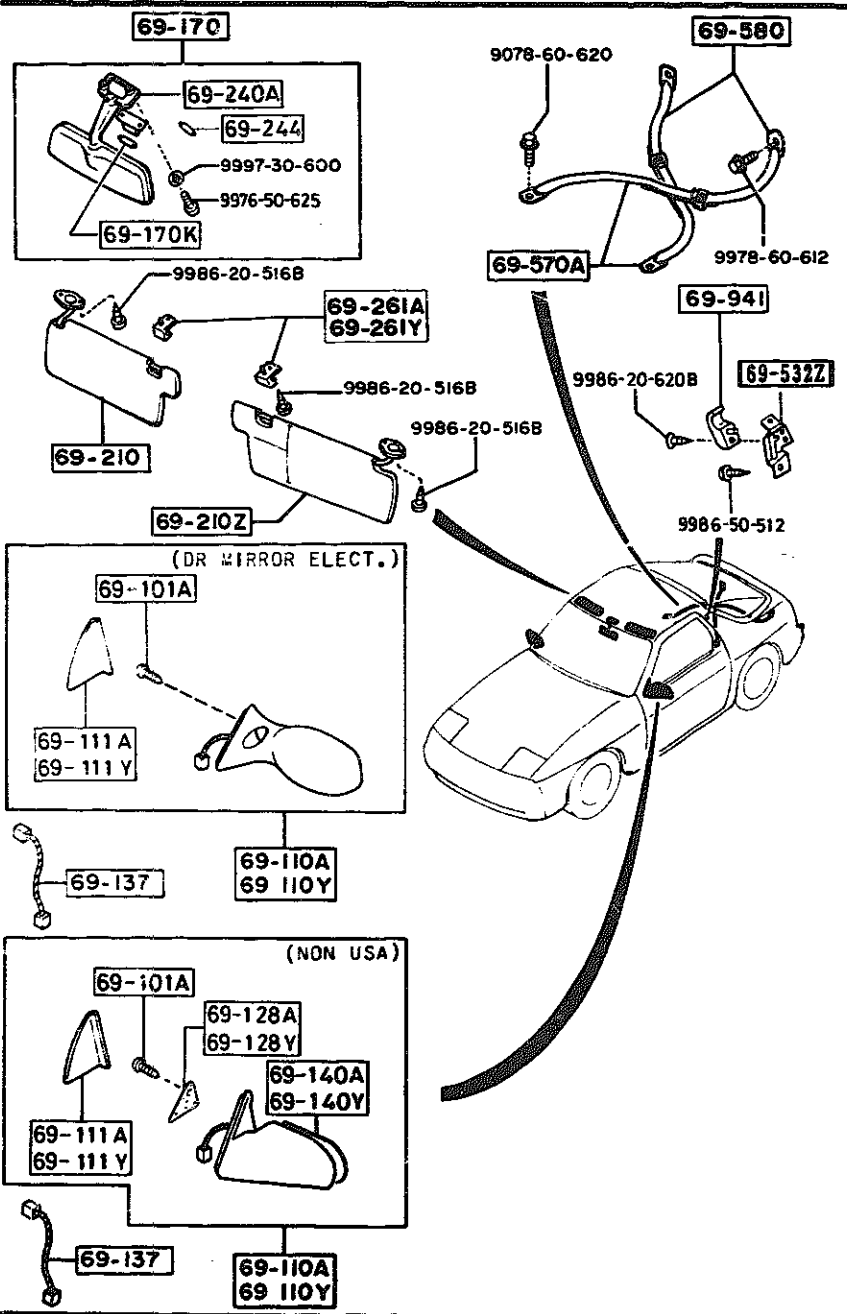

AUFA02

6900 -4 * VISORS, ASSIST HANDLES & MIRRORS (COUPE)

PART NO.	QTY	MODEL/RESTRICTION	MODEL/RESTRICTION	MODEL/RESTRICTION	FROM-TO
CONT'D					
* 02		F08 BLACK			
19		F09 RED			
48		FD9 BLUE			
69-580		STRAP 'B', CARGOROOM			
FA54-69-572	2	GTUS, GXL, TURBO, (W/CARGO ROOM STRAP)			
* 02		F08 BLACK			
19		F09 RED			
48		FD9 BLUE			
69-941		HANGER, COAT			
F801-69-531	1				
02		FD8 FE1 BLACK			
19		F09 RED			
48		FD9 BLUE			

CAT. AUFA02-06

1992-05

4-G12

6900A VISORS, ASSIST HANDLES & MIRRORS
(CONVERTIBLE)

6900A -1 VISORS, ASSIST HANDLES & MIRRORS
(CONVERTIBLE)

FROM-TO

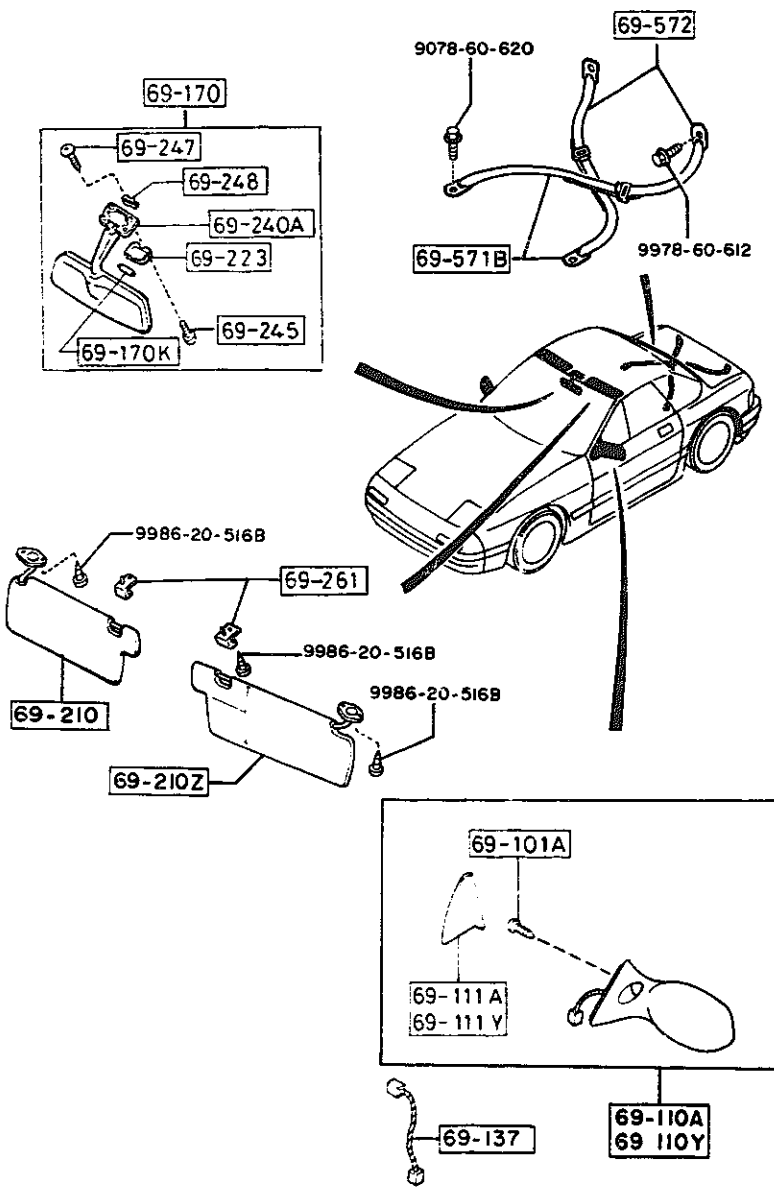

PART NO.	QTY	MODEL/RESTRICTION	MODEL/RESTRICTION	MODEL/RESTRICTION	FROM-TO
69-101A		SCREW, DOOR MIRROR			
G032-69-126	6	ICHIKO			
69-110A		MIRROR(R), DOOR			
FC01-69-110	1				
PZ		PZ BRILLIANT BLACK			
SQ		SQ BLAZE RED			
UC		UC CRYSTAL WHITE			
WY		WY NOBLE WHITE			
1F		1F WINNING SILVER M.			
3G		3G SHADOW SILVER METALL			
5D		5D HARBOR BLUE M.			
6H		6H MELLOW BURGUNDY MC			
69-110Y		MIRROR(L), DOOR			
FC01-69-170	1				
PZ		PZ BRILLIANT BLACK			
SQ		SQ BLAZE RED			
UC		UC CRYSTAL WHITE			
WY		WY NOBLE WHITE			
1F		1F WINNING SILVER M.			
3G		3G SHADOW SILVER METALL			
5D		5D HARBOR BLUE M.			
6H		6H MELLOW BURGUNDY MC			
69-111A		GARNISH(R), SAIL-IN.			
F045-69-112A	1				
69-111Y		GARNISH(L), SAIL-IN.			
F045-69-172A	1				
69-137		WIRE, REMOCON. MIRROR			
F045-69-108A	2				

1992-05

AUFA02

CAT. AUFA02-06

1992-05

4-H12

6900A VISORS, ASSIST HANDLES & MIRRORS (CONVERTIBLE)

6900A -2 VISORS, ASSIST HANDLES & MIRRORS (CONVERTIBLE)

FROM-TO

-9A01
9A01-
-9A01
9A01-

1992-05

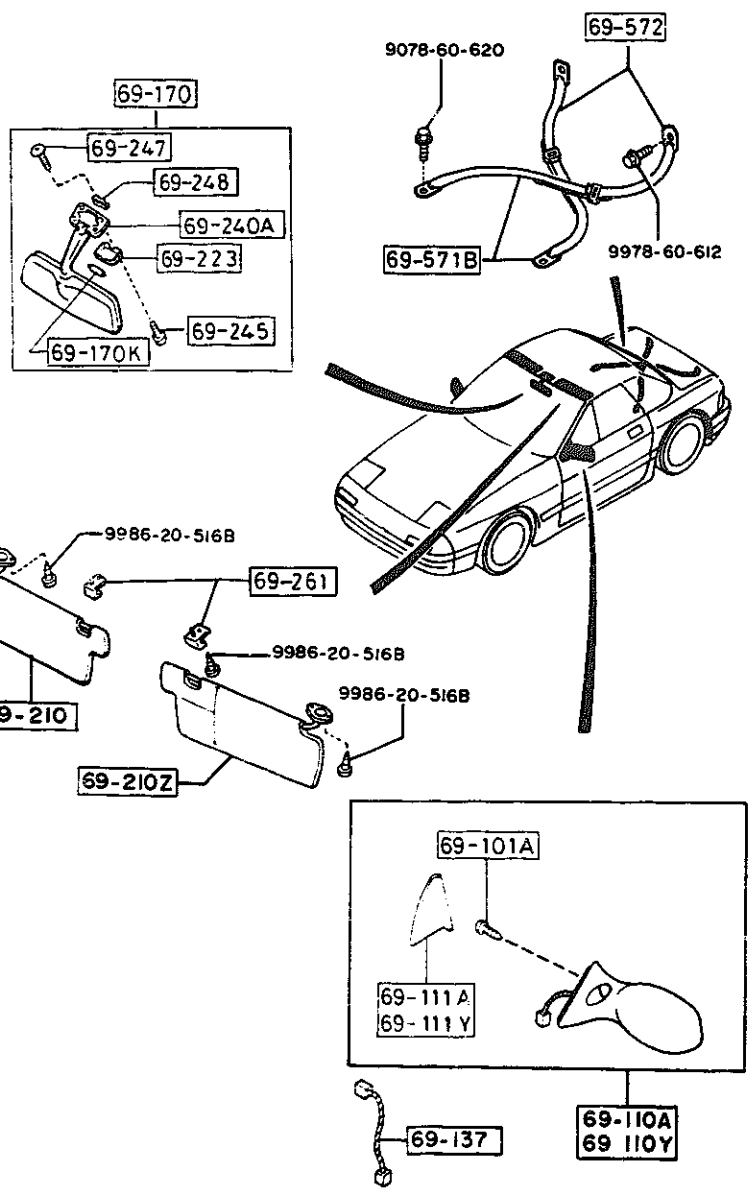

PART NO.	QTY	MODEL/RESTRICTION	MODEL/RESTRICTION	MODEL/RESTRICTION	FROM-TO
69-170		MIRROR, INTERIOR			
FB68-69-220B	1				
02		FD8 FE1 BLACK			
48		FD9 BLUE			
69-170K		BULB, INTERIOR MIRROR			
99700-5100	1	12V 10W			
69-210		SUN VISOR(R)			
FB67-69-270A	1				
02		FD8 FE1 BLACK			
48		FD9 BLUE			
69-210Z		SUN VISOR(L)			
FB67-69-320A	1	(W/O AIR BAG)			
02		FD8 FE1 BLACK			
48		FD9 BLUE			
FC66-69-320A (FC66-69-320A)	1				-9C01
02		FD8 FE1 BLACK			
48		FD9 BLUE			
FC66-69-320A	1	(W/AIR BAG)			9C01-
02		FD8 FE1 BLACK			
48		FD9 BLUE			
69-223		LENS, INTERIOR LAMP			
FB67-69-233	1				
69-240A		BASE, INTERIOR MIRROR			
FB67-69-240	1				
02		FD8 FE1 BLACK			
48		FD9 BLUE			
69-245		SCREW, INTERIOR MIRROR			
FB67-69-245	2				
69-247		HOLDER, PIN			
FB67-69-247	1				
9C01 FCS***-804800					

AUFA02

CAT. AUFA02-06

1992-05

6900A VISORS, ASSIST HANDLES & MIRRORS
(CONVERTIBLE)

6900A -3 * VISORS, ASSIST HANDLES & MIRRORS
(CONVERTIBLE)

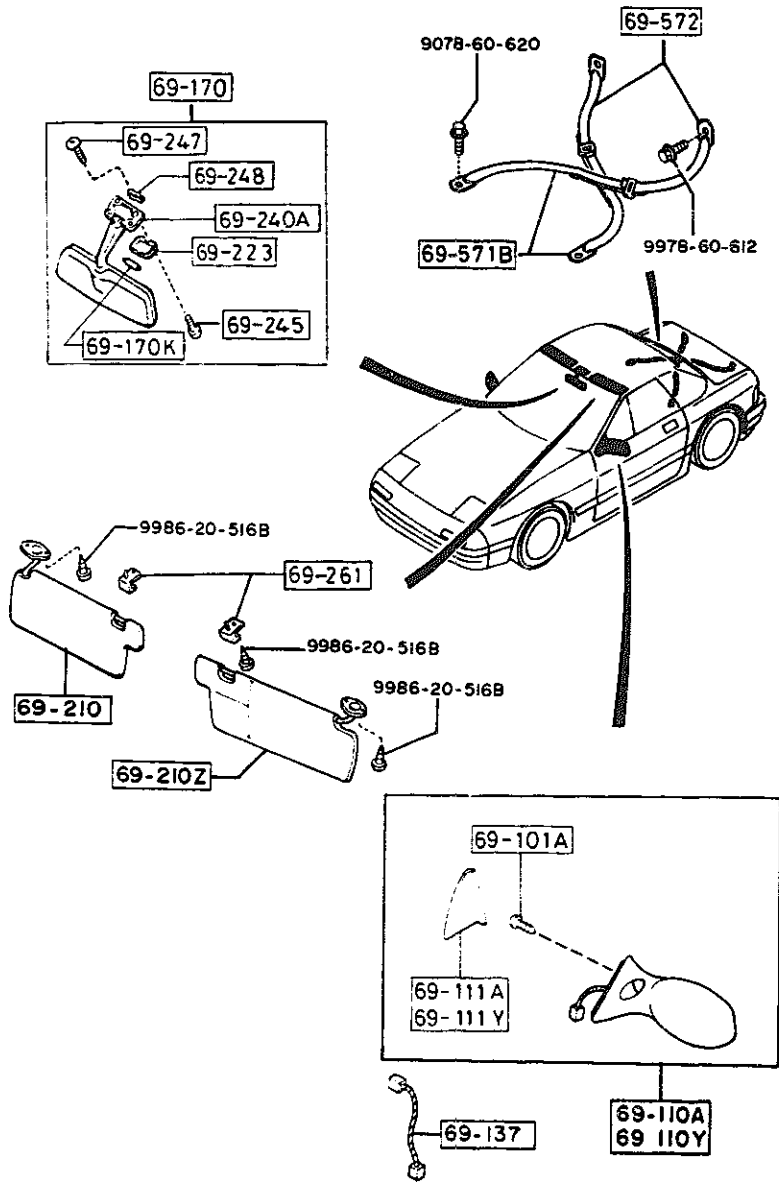

PART NO.	QTY	MODEL/RESTRICTION	MODEL/RESTRICTION	MODEL/RESTRICTION	FROM-TO
69-248		SPRING, INTERIOR MIRROR			
FB67-69-248	1				
69-261		ADAPTER, SUN VISOR			
H260-69-261	2				
02		FD8 FE1 BLACK			
48		FD9 BLUE			
69-571B		STRAP 'A', L/CPMT			
FB67-69-571	2				
69-572		STRAP 'B', L/CPMT			
FB67-69-572	2				

6930 CAUTION PLATES & LABELS

6930 -1 CAUTION PLATES & LABELS

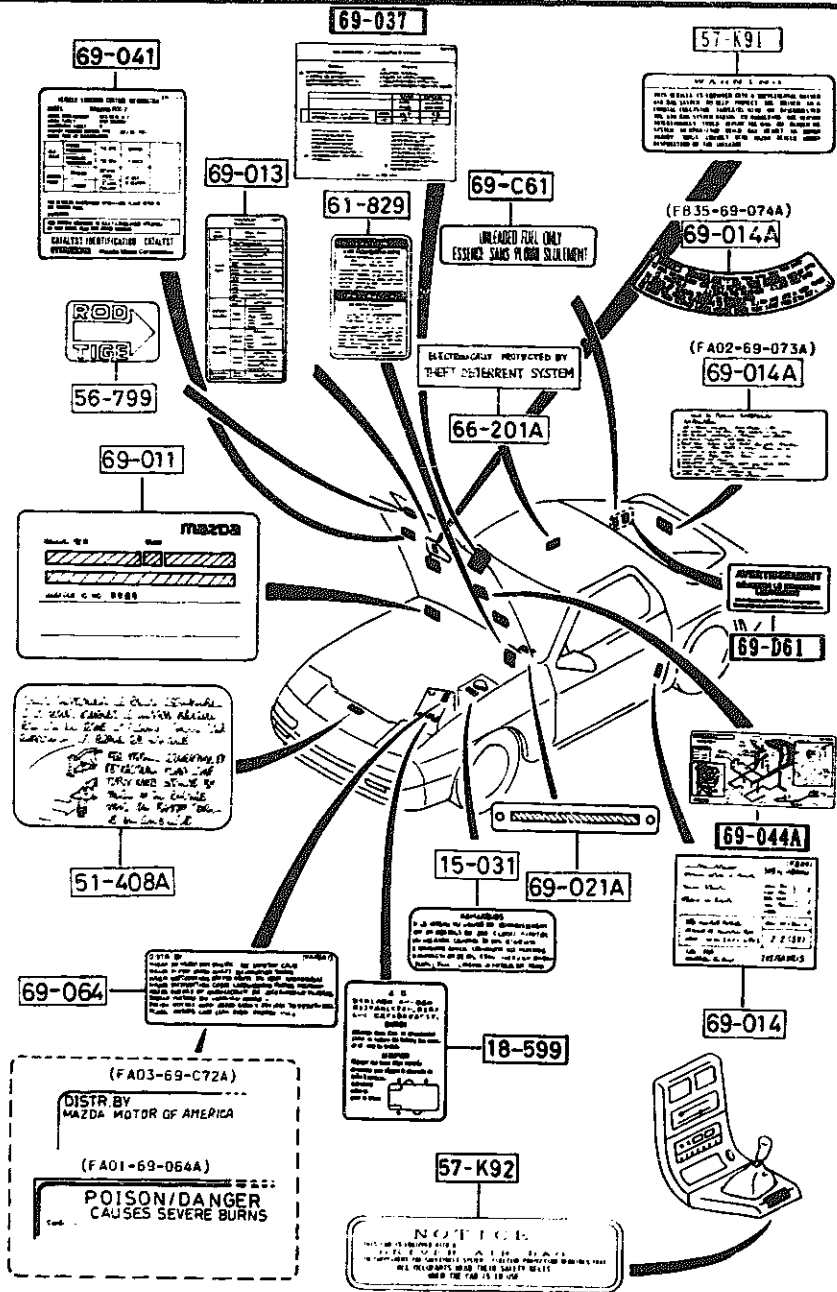

PART NO.	QTY	MODEL/RESTRICTION	MODEL/RESTRICTION	MODEL/RESTRICTION	FROM-TO
15-031		LABEL, CAUTION			
8871-15-357	1	(W/SUB TANK LABEL)			
18-599		LABEL, CAUTION-BATTERY BOX			
N318-18-599	1				
51-408A		LABEL, CAUTION-RETRACTABLE			
FB34-51-408	1				
56-799		LABEL, BONNET STAY			
UB39-56-799	1				
57-K91		LABEL 'A', CAUTION-A/B			
*NA01-57-K91	1				
57-K92		LABEL 'B', CAUTION-A/B			
NA91-57-K92	1				
61-829		LABEL, CAUTION			
FB01-61-439B	1				
66-201A		LABEL, BURGLAR ALARM			
FB01-66-201	1				
69-C61		LABEL, UNLEADED FUEL			
UB40-69-C61	1	(W/O AIR BAG)			-0401
UB39-69-C61	1	(W/AIR BAG)			0401-
UB40-69-C61	1	(W/AIR BAG)			
69-D61		LABEL, FUEL WARNING			
KA10-69-D61	1				9601-
69-011		PLATE, MODEL			
8595-69-011B	1				-9508
69-013		LABEL, OIL			
FB01-69-D21A	1				
69-014		LABEL, TIRE			
FB05-69-014A	1	((CPE))>(2SEATER)>(NO R. SUSP)>(A.A.SUSP)			
9508 FC3MM-707092					
9601 FC3MM-708021					
0401 FC3MM-806597					

6930 CAUTION PLATES & LABELS

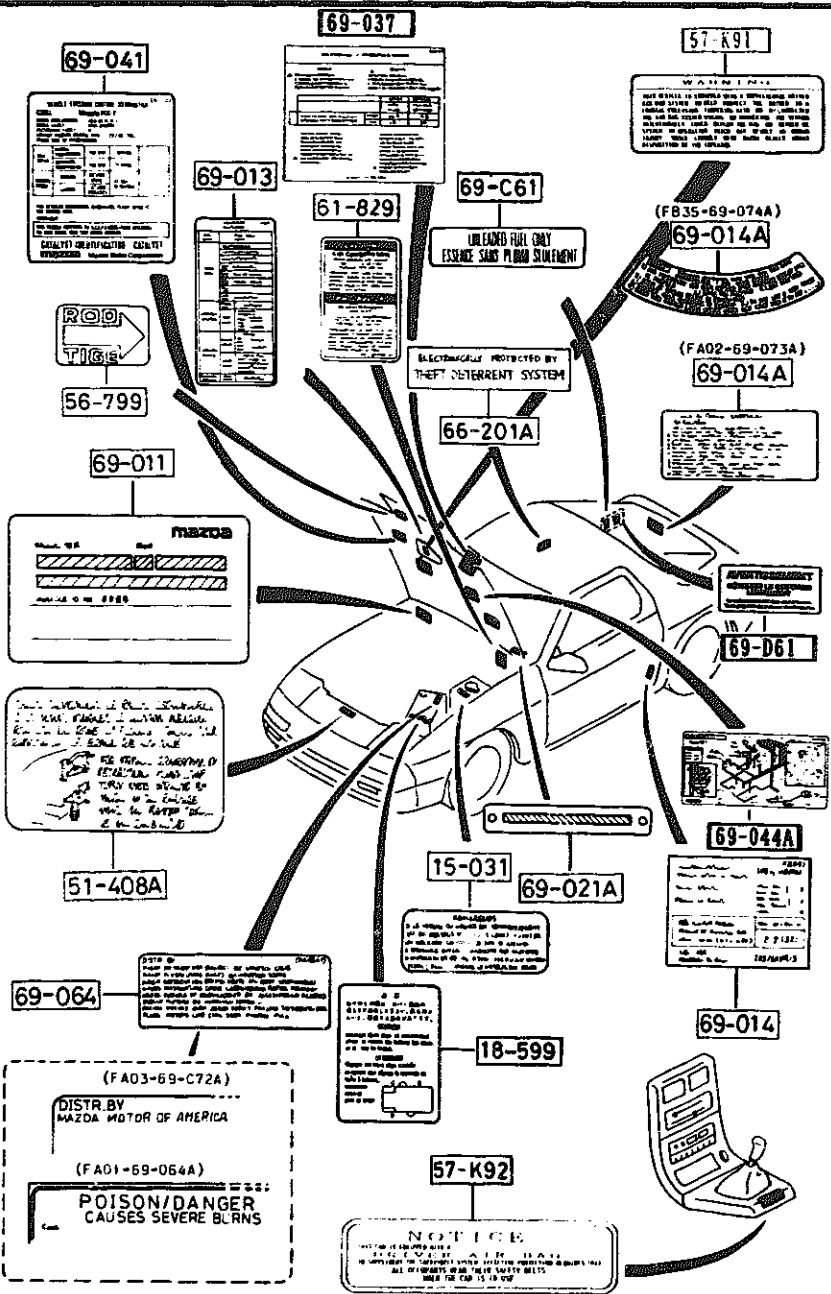

PART NO.	QTY	MODEL/RESTRICTION	MODEL/RESTRICTION	MODEL/RESTRICTION	FROM-TO
CONT'D		(CONVERTIBLE)			
FB09-69-014	1	((CPE))>>(4SEATER))			
FC01-69-014A	1	((CPE))>>(2SEATER)>>(NOR.SUSP)>>(W/O A.A.SUSP))			
FC17-69-014A	1	((CPE))>>(2SEATER)>>(HARD SUSP))			
69-014A		LABEL, TEMPORARY TIRE			
FA02-69-073A	1	ENGLISH (HARD SUSP)			
FB35-69-074A	1	ENGLISH (NOR.SUSP)			
69-021A		PLATE, CAUTION			
GA02-69-068	1	(W/O AIR BAG)			
NA01-69-068	1	(W/AIR BAG)			
69-037		LABEL, FUEL ECONOMY			
N353-69-042	1	(W/FUEL CONSUMPTION LABEL) ((CONVERTIBLE))>>(W/O AIR BAG)) ((CPE))>>(NOR.SUSP))			-9701
N373-69-042	1	((CPE))>>(HARD SUSP))			-9701
N373-69-042A	1	((CPE))>>(HARD SUSP))			9701-
N353-69-042A A (N353-69-042B)	1				9701-9801
N353-69-042B	1	(W/FUEL CONSUMPTION LABEL) ((CONVERTIBLE))>>(W/O AIR BAG)) ((CPE))>>(NOR.SUSP))			9801-
69-041		LABEL, EMISSION			
N350-69-036	1	(W/EM LABEL-FED.) (W/O TURBO)			-9701
N351-69-036	1	(W/EM LABEL-CALIF.) (W/O TURBO)			-9701
N370-69-036	1	(W/EM LABEL-FED.) (TURBO)			-9701
N371-69-036	1	(W/EM LABEL-CALIF.) (TURBO)			-9701
N350-69-036A	1	(W/EM LABEL-FED.) (W/O TURBO)			9701-
N351-69-036A	1	(W/EM LABEL-CALIF.)			9701-

9701 FC3MM-709151
9801 FC3MM-804224

FROM-TO

-9101

9101-

1992-05

AUFA02

CAT. AUFA02-06

1992-05

4-L12

FROM-TO

6930 CAUTION PLATES & LABELS

6930 -3 * CAUTION PLATES & LABELS

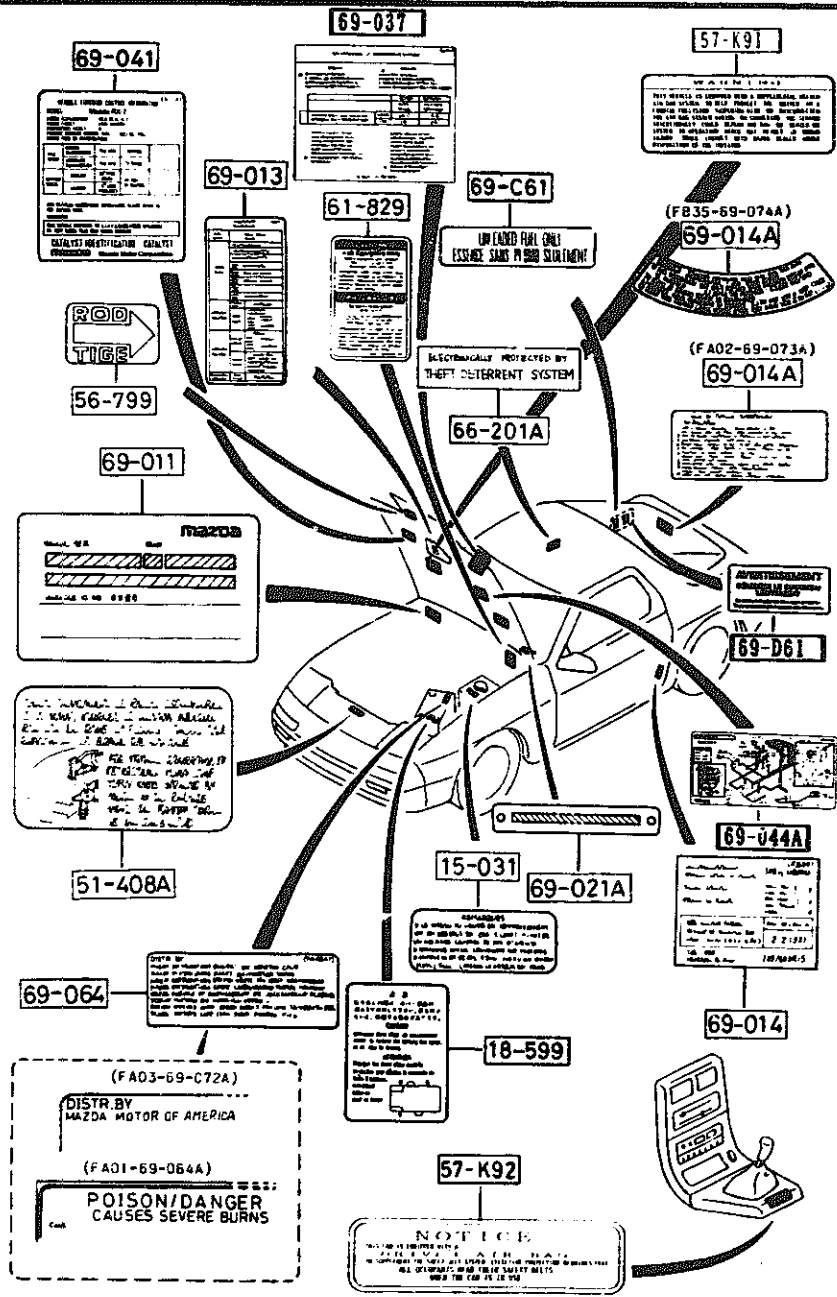

PART NO.	QTY	MODEL/RESTRICTION	MODEL/RESTRICTION	MODEL/RESTRICTION	FROM-TO
CONT'D					
		(W/O TURBO)			
N370-69-036A	1	(W/EM LABEL-FED.) (TURBO)			9701-
N371-69-036A	1	(W/EM LABEL-CALIF.) (TURBO)			9701-
		69-044A	LABEL, VAC. DIAPHRAGM		
N350-69-044A	1	(W/O TURBO)			-9701
N370-69-044A	1	(TURBO)			-9701
N350-69-044B	1	(W/O TURBO)			9701-
N370-69-044B	1	(TURBO)			9701-
		69-064	LABEL, BATTERY		
FA01-69-064A	1				
FA03-69-C72 A (FA03-69-C72A)	1				-9728
FA03-69-C72A	1				9728-

9701 FC3MM-709151
 9728 FC3MM-800035
 FC3MM-800721

-9801

801-

1992-05

AUFA02

CAT. AUFA02-06

1992-05

4-M12

7250 QUARTER WINDOW & TRIMS

(CPE)

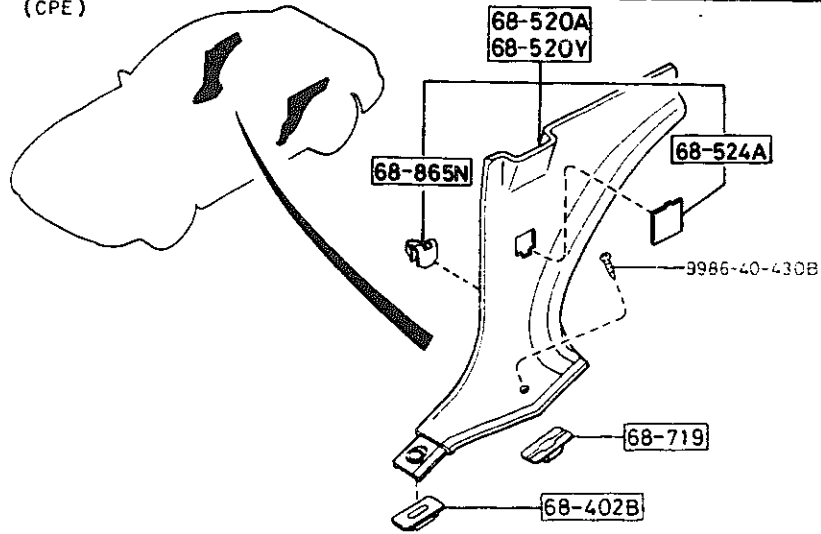

(CONVERTIBLE)

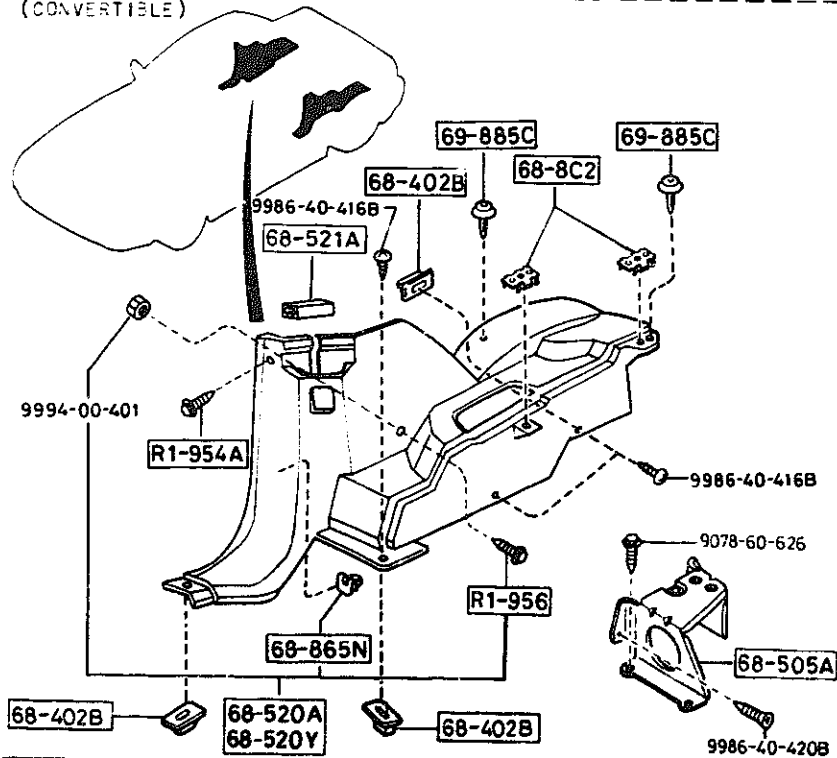

7250 -1 QUARTER WINDOW & TRIMS

PART NO.	QTY	MODEL/RESTRICTION	MODEL/RESTRICTION	MODEL/RESTRICTION	FROM-10
R1-954A		HOOK, SCREW-QTR TRIM			
FB67-R1-954A	2	(CONVERTIBLE)			
R1-956		HOOK, SCREW-QTR TRIM			
FB67-R1-956A	2	(CONVERTIBLE)			
68-402B		GROMMET, SCREW			
FA54-68-719B	2	(CPE)			
	8	(CONVERTIBLE)			
68-505A		BRACKET, QUARTER TRIM			
FB67-68-505B	1	(CONVERTIBLE)			
68-520A		TRIM(R), QUARTER			
FB67-68-520E	1	(CONVERTIBLE)			
02		FD8 FE1 BLACK			
48		FD9 BLUE			
FC01-68-520A (FC01-68-520A)	1				-9113
02		FD8 BLACK			
19		FE0 RED			
48		FD9 BLUE			
FC20-68-520A (FC20-68-520A)	1				-9113
02		FD8 BLACK			
19		FE0 RED			
48		FD9 BLUE			
FC01-68-520A	1	((CPE)) (2SEATER)			9113-
02		FD8 FE1 BLACK			
19		FE0 RED			
48		FD9 BLUE			
FC20-68-520A	1	((CPE)) (4SEATER)			9113-
02		FD8 FE1 BLACK			
19		FE0 RED			
48		FD9 BLUE			
68-520Y		TRIM(L), QUARTER			
FB67-68-550E	1	(CONVERTIBLE)			

9113 FC3MM-70067

AUFA02

CAT. AUFA02-06

SECTION NAME INDEX (BODY) 2/2

LO.NO	SEC.NO	SECTION NAME	LO.NO	SEC.NO	SECTION NAME	LO.NO	SEC.NO	SECTION NAME
4-C03	6100	HEATER	4-E08	6703	WIRING HARNESSSES(DOOR,FLOOR/CEILING)			
4-E03	6110	HEATER UNIT COMPONENTS	4-G08	6704	WIRING HARNESS CLAMPS			
4-F03	6115	HEATER CONTROLS COMPONENTS	4-J08	6720	WINDSHIELD WASHER (1.5L & 2.5L)			
4-G03	6120	HEATER BLOWER COMPONENTS	4-L08	6720 A	WINDSHIELD WASHER (5.7L)			
4-I03	6130	AIR CONDITIONER	4-N08	6730	WINDSHIELD WIPERS			
4-J03	6230	LIFT GATE MECHANISMS (COUPE)	4-C09	6740	WIPER MOTOR COMPONENTS(FRONT)			
4-M03	6300	WINDOW GLASSES (COUPE)	4-D09	6750	WINDOW WIPER & WASHER (REAR)			
4-N03	6300A	WINDOW GLASSES (CONVERTIBLE)	4-G09	6760	WINDOW WIPER MOTOR COMPONENTS (REAR)			
4-C04	6330	SUNROOF (COUPE)	4-H09	6800	CEILING TRIMS (COUPE)			
4-G04	6330A	SUNROOF (CONVERTIBLE)	4-J09	6800A	CEILING TRIMS (CONVERTIBLE)			
4-M04	6600	SWITCHES & RELAYS (ENGINE)	4-K09	6810	ROLLEBAR (CONVERTIBLE)			
4-G05	6610	DASHBOARD SWITCHES	4-N09	6820	PILLAR TRIMS (COUPE)			
4-H05	6611	COMBINATION SWITCH	4-F10	6820A	PILLAR TRIMS (CONVERTIBLE)			
4-I05	6612	CLUSTER SWITCH	4-G10	6840	TRIMS & SCUFF PLATES (COUPE)			
4-L05	6615	POWER WINDOW SWITCHES	4-L10	6840A	TRIMS & SCUFF PLATES (CONVERTIBLE)			
4-M05	6630	RELAYS & UNIT (BODY)	4-N10	6845	STRAGE BOX (COUPE)			
4-D06	6635	DOOR SWITCH & HORNS			(GXL,TURBO)			
4-F06	6640	AUTO CRUISE CONTROL SYSTEM	4-D11	6860	FLOOR MATS & PADS (COUPE)			
4-F06	6680	AUDIO SYSTEMS (RADIO & TAPE DECK) (COUPE)	4-K11	6860A	FLOOR MATS & PADS (CONVERTIBLE)			
4-K06	6680 A	AUDIO SYSTEMS (RADIO & TAPE DECK) (CONVERTIBLE)	4-C12	6870	SERVICE TOOLS			
4-M06	6682	AUDIO SYSTEMS (ANTENNA & SPEAKER) (COUPE)	4-D12	6900	VISORS,ASSIST HANDLES & MIRRORS (COUPE)			
4-D07	6682 A	AUDIO SYSTEMS (ANTENNA & SPEAKER) (CONVERTIBLE)	4-H12	6900A	VISORS,ASSIST HANDLES & MIRRORS (CONVERTIBLE)			
4-G07	6684	AUDIO SYSTEMS(NOISE SUPPRESSOR & EARTH CORD)	4-K12	6930	CAUTION PLATES & LABELS			
4-H07	6700	WIRING HARNESSSES(FRONT & REAR)	4-N12	7250	QUARTER WINDOW & TRIMS			
4-N07	6701	WIRING HARNESSSES(ENGINE & TRANSMISSION)	4-E13	7800	SPOILERS & RELATED PARTS			
4-D08	6702	WIRING HARNESSSES(DASHBOARD)	4-C14	7900	ACCESSORIES			



2-05

CATLOG-NO= AUFA02-06

DATE. 1992-05

4-B13

725C QUARTER WINDOW & TRIMS

(CPE)

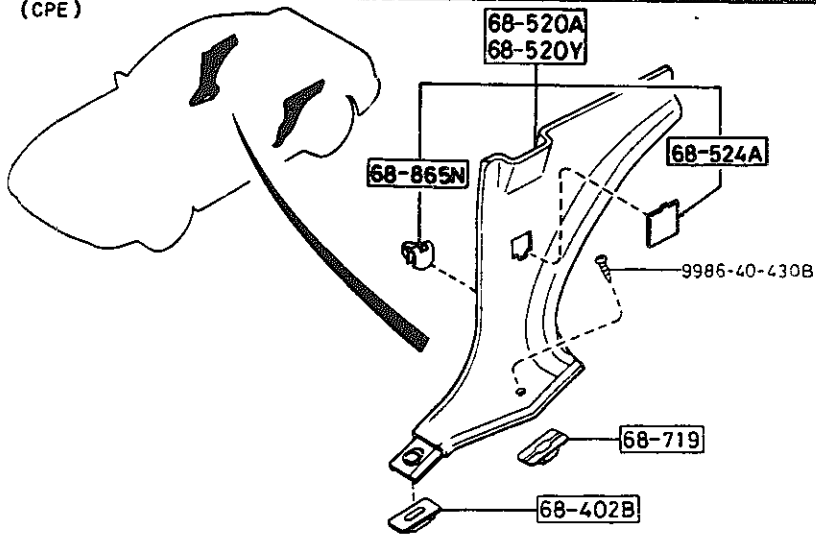

(CONVERTIBLE)

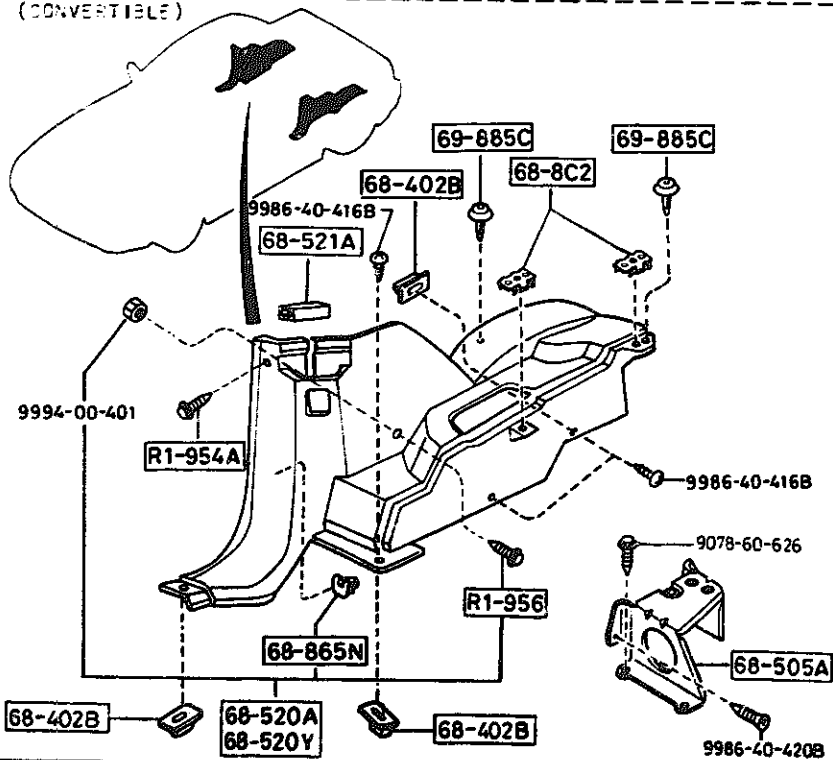

7250 -2 QUARTER WINDOW & TRIMS

PART NO.	QTY	MODEL/RESTRICTION	MODEL/RESTRICTION	MODEL/RESTRICTION	FROM-TO
CONT'D					
02		FD8 FE1 BLACK			
48		FD9 BLUE			
FC01-68-550 A (FC01-68-550A)	1				-9113
02		FD8 BLACK			
19		FE0 RED			
48		FD9 BLUE			
FC20-68-550 A (FC20-68-550A)	1				-9113
02		FD8 BLACK			
19		FE0 RED			
48		FD9 BLUE			
FC01-68-550A	1	((CPE))<(2SEATER))			9113-
02		FD8 FE1 BLACK			
19		FE0 RED			
48		FD9 BLUE			
FC20-68-550A	1	((CPE))<(4SEATER))			9113-
02		FD8 FE1 BLACK			
19		FE0 RED			
48		FD9 BLUE			
68-521A		CLIP,QUATER TRIM			
FB67-68-523	2	(CONVERTIBLE)			
68-524A		COVER,HOLE-QTR TRIM			
FC01-68-524	2	(CPE)			
02		FD8 FE1 BLACK			
19		FE0 RED			
48		FD9 BLUE			
68-719		GROMMET,SCREW			
FB01-68-719	2	(CPE)			
68-8C2		NUT,EXPANSION			
FB67-68-8C2	4	(CONVERTIBLE)			
68-865N		CLIP,TRIM			
9113 FC3NNH-700067					

CAT. AUFA02-06

1992-05

AUFA02

1992-05

7250 QUARTER WINDOW & TRIMS

(CPE)

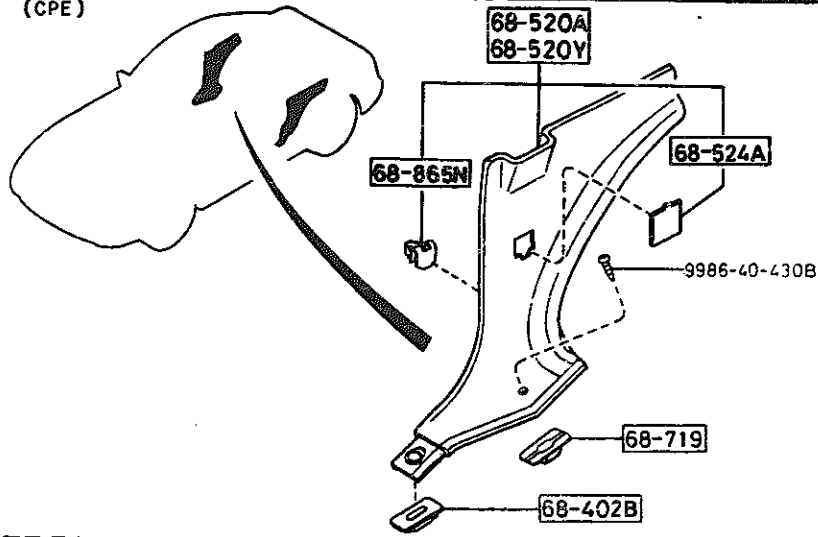

(CONVERTIBLE)

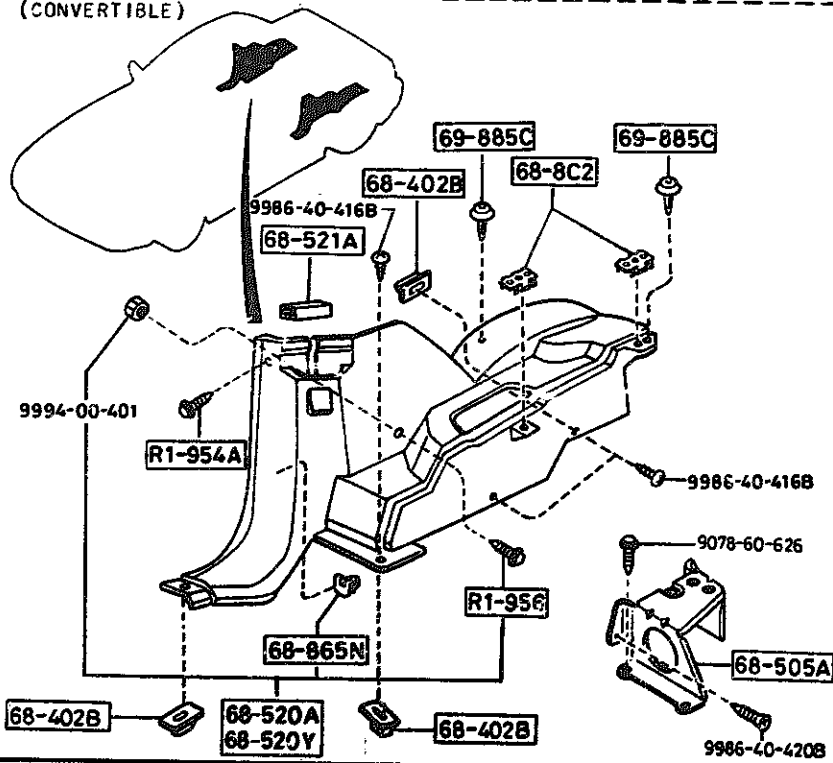

PART NO.	QTY	MODEL/RESTRICTION	MODEL/RESTRICTION	MODEL/RESTRICTION	FROM-TO
CONT'D H002-68-865	16				
69-885C		FASTENER			
UB54-68-885	4	(CONVERTIBLE)			
00		FE0 FE1 FD8 BLACK			
48		FD9 BLUE			

FROM-TO

4-D13

FROM-TO

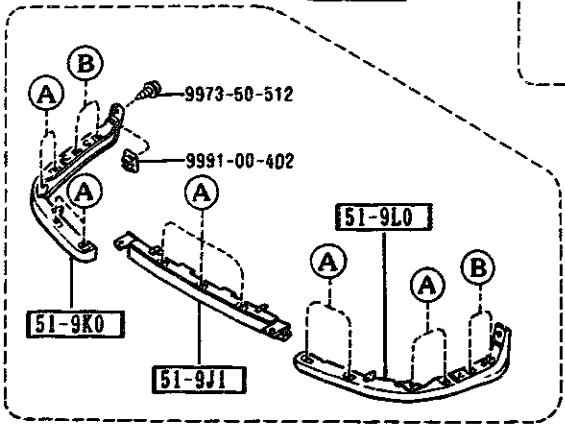
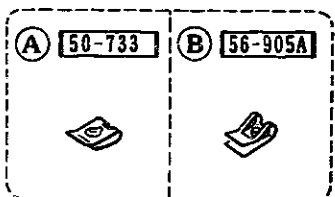
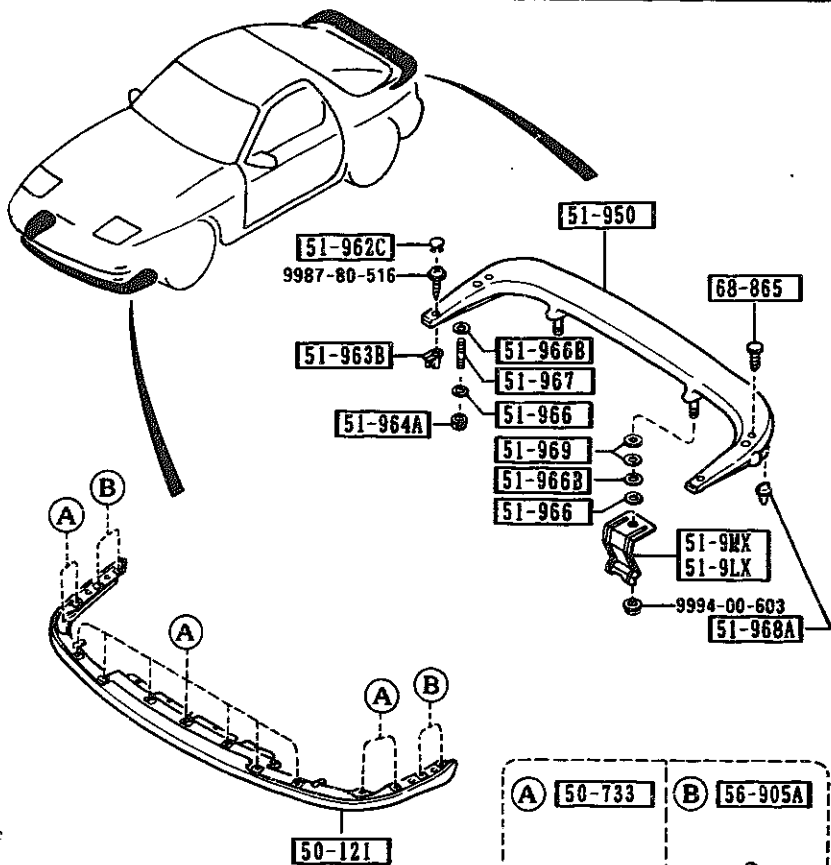

PART NO.	QTY	MODEL/RESTRICTION	MODEL/RESTRICTION	MODEL/RESTRICTION	FROM-TO
50-121		DAM,AIR-SKIRT			
FC17-51-9HGA	1	TURBO, (W/AERO PARTS KIT)			
PZ		PZ BRILLIANT BLACK			
SQ		SQ BLAZE RED			
UC		UC CRYSTAL WHITE			
WY		WY NOBLE WHITE			
1F		1F WINNING SILVER M.			
3G		3G SHADOW SILVER METALL			
5D		5D HARBOR BLUE M.			
6H		6H MELLOW BURGUNDY MC			
50-733		NUT,SPRING-AIR DAM S KIRT			
FB01-50-733	11				
51-9J1		DAM(C),AIR-SKIRT			
FC01-51-9J1A	1				
51-9K0		SKIRT(R),FRONT AIR D AM			
FC01-51-9K1A	1				
51-9LX		STIFFNER(L),REAR SPO ILER			
FB02-51-9LXB	1	GTU-OPT, GTUS, GXL, TURBO, (W/RR SPOILER) (CPE)			
51-9L0		SKIRT(L),FRONT AIR D AM			
FC01-51-9L1A	1				
51-9MX		STIFFNER(R),REAR SPO ILER			
FB02-51-9MXB	1	GTU-OPT, GTUS, GXL, TURBO, (W/RR SPOILER) (CPE)			
51-950		SPOILER,REAR			
FC17-51-961	1	GTU-OPT, GTUS, GXL, TURBO, (W/RR SPOILER) (CPE)			-9901
PZ		PZ BRILLIANT BLACK			
9901 FC3***N-802200					

1992-05

AUFA02

CAT. AUFA02-06

1992-05

4-E13

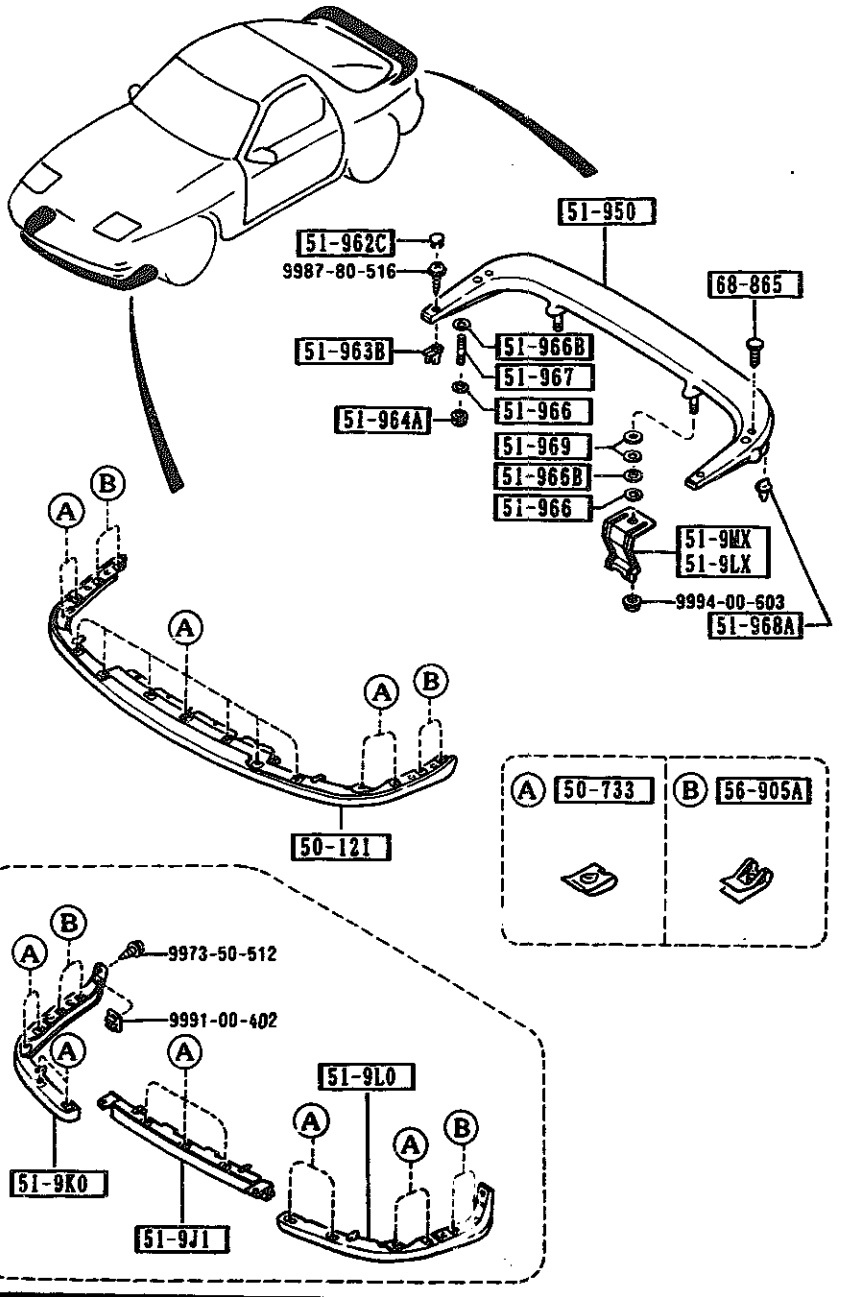

PART NO.	QTY	MODEL/RESTRICTION	MODEL/RESTRICTION	MODEL/RESTRICTION	FROM-TO
CONT'D					
SQ		SQ BLAZE RED			
UC		UC CRYSTAL WHITE			
WY		WY NOBLE WHITE			
1F		1F WINNING SILVER M.			
3G		3G SHADOW SILVER METALL			
5D		5D HARBOR BLUE M.			
6H		6H MELLOW BURGUNDY MC			
FC17-51-960A	1	GTU-OPT, GTUS, GXL, TURBO, (W/RR SPOILER) (CPE)			9901-
PZ		PZ BRILLIANT BLACK			
SQ		SQ BLAZE RED			
UC		UC CRYSTAL WHITE			
1F		1F WINNING SILVER M.			
3G		3G SHADOW SILVER METALL			
5D		5D HARBOR BLUE M.			
		51-962C	CAP, REAR SPOILER		
FB03-51-962	2	GTU-OPT, GTUS, GXL, TURBO, (W/RR SPOILER) (CPE)			
PZ		PZ BRILLIANT BLACK			
SQ		SQ BLAZE RED			
UC		UC CRYSTAL WHITE			
WY		WY NOBLE WHITE			
1F		1F WINNING SILVER M.			
3G		3G SHADOW SILVER METALL			
5D		5D HARBOR BLUE M.			
6H		6H MELLOW BURGUNDY MC			
		51-963B	GROMMET, SCREW-REAR SPOILER		
FB02-51-963A	2	GTU-OPT, GTUS, GXL, TURBO, (W/RR SPOILER) (CPE)			

9901 FC3MMH-802200

7800 SPOILERS & RELATED PARTS

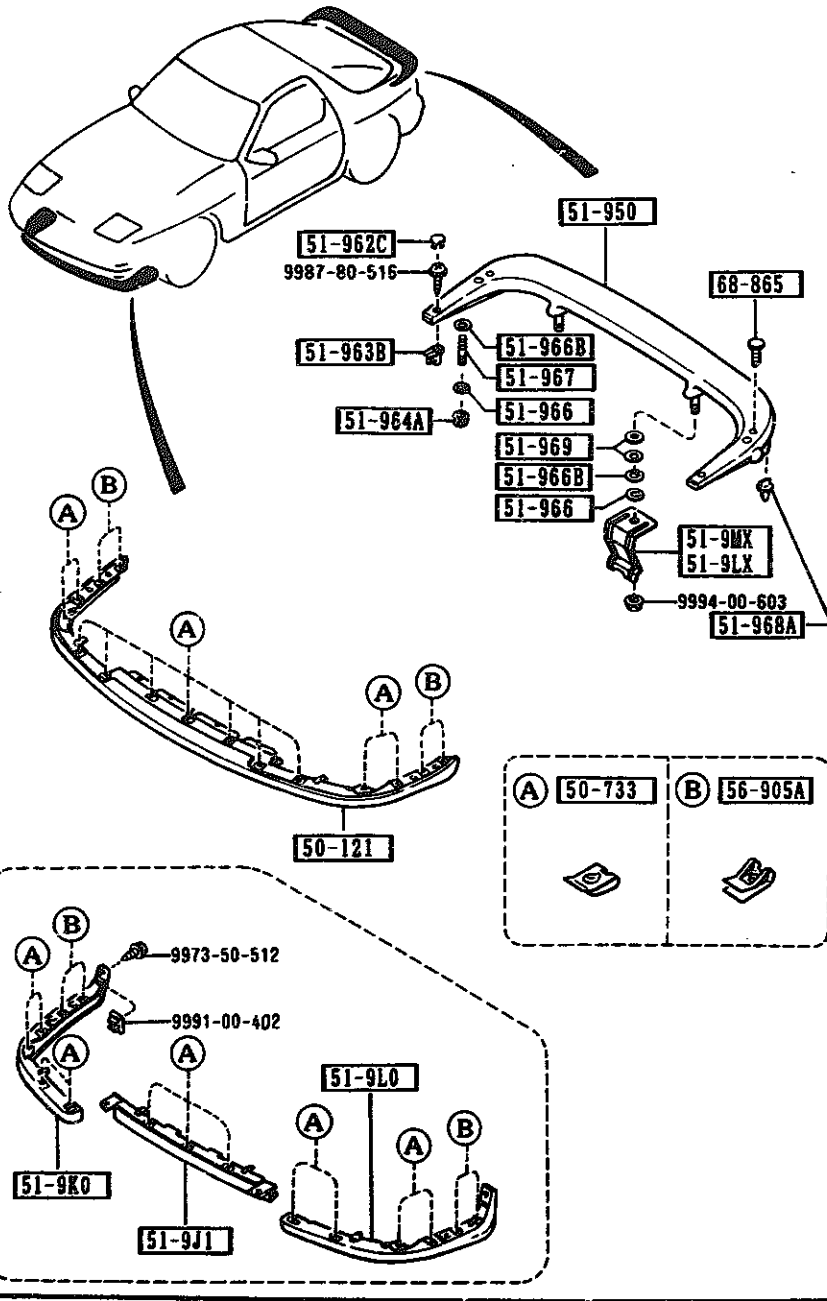

PART NO.	QTY	MODEL/RESTRICTION	MODEL/RESTRICTION	MODEL/RESTRICTION	FROM-TO
51-964A		NUT, CAP-REAR SPOILER			
FB02-51-964A	2	GTU-OPT, GTUS, GXL, TURBO, (W/RR SPOILER) (CPE)			
51-966		PROTECTOR			
FB01-51-966B	4	GTU-OPT, GTUS, GXL, TURBO, (W/RR SPOILER) (CPE)			
51-966B		GASKET, SPOILER			
FB02-51-966	4	GTU-OPT, GTUS, GXL, TURBO, (W/RR SPOILER) (CPE)			9901-
51-967		BOLT			
FC17-51-967	2	GTU-OPT, GTUS, GXL, TURBO, (W/RR SPOILER) (CPE)			-9901
51-968A		CLIP			
FC17-51-968	2	GTU-OPT, GTUS, GXL, TURBO, (W/RR SPOILER) (CPE)			
51-969		PROTECTOR, RR SPOILER -CTR			
FC17-51-969	4	GTU-OPT, GTUS, GXL, TURBO, (W/RR SPOILER) (CPE)			9901-
56-905A		NUT, SPRING			
W023-60-122	4				
68-865		FASTENER			
G045-68-865	2	GTU-OPT, GTUS, GXL, TURBO, (W/RR SPOILER) (CPE)			
00		FED F08 FD9 BLACK			
9901 FC3***-802200					

1992-05

AUFA02

CAT. AUFA02-06

1992-05

SECTION NAME INDEX (BODY) 2/2

LG.NO	SEC.NO	SECTION NAME	LG.NO	SEC.NO	SECTION NAME	LG.NO	SEC.NO	SECTION NAME
4-C03	6100	HEATER	4-E08	6703	WIRING HARNESSSES(DOOR,FLOOR/CEILING)			
4-E03	6110	HEATER UNIT COMPONENTS	4-G08	6704	WIRING HARNESS CLAMPS			
4-F03	6115	HEATER CONTROLS COMPONENTS	4-J08	6720	WINDSHIELD WASHER (1.5L & 2.5L)			
4-G03	6120	HEATER BLOWER COMPONENTS	4-L08	6720 A	WINDSHIELD WASHER (5.7L)			
4-I03	6130	AIR CONDITIONER	4-N08	6730	WINDSHIELD WIPERS			
4-J03	6230	LIFT GATE MECHANISMS (COUPE)	4-C09	6740	WIPER MOTOR COMPONENTS(FRONT)			
4-M03	6300	WINDOW GLASSES (COUPE)	4-D09	6750	WINDOW WIPER & WASHER (REAR)			
4-N03	6300A	WINDOW GLASSES (CONVERTIBLE)	4-G09	6760	WINDOW WIPER MOTOR COMPONENTS (REAR)			
4-C04	6330	SUNROOF (COUPE)	4-H09	6800	CEILING TRIMS (COUPE)			
4-G04	6330A	SUNROOF (CONVERTIBLE)	4-J09	6800A	CEILING TRIMS (CONVERTIBLE)			
4-M04	6600	SWITCHES & RELAYS (ENGINE)	4-K09	6810	ROLLED... (CONVERTIBLE)			
4-G05	6610	DASHBOARD SWITCHES	4-N09	6820	PILLAR TRIMS (COUPE)			
4-H05	6611	COMBINATION SWITCH	4-F10	6820A	PILLAR TRIMS (CONVERTIBLE)			
4-I05	6612	CLUSTER SWITCH	4-G10	6840	TRIMS & SCUFF PLATES (COUPE)			
4-L05	6615	POWER WINDOW SWITCHES	4-L10	6840A	TRIMS & SCUFF PLATES (CONVERTIBLE)			
4-M05	6630	RELAYS & UNIT (BODY)	4-N10	6845	STRAGE BOX (COUPE)			
4-D06	6635	DOOR SWITCH & HORNS			(GXL,TURBO)			
4-E06	6640	AUTO CRUISE CONTROL SYSTEM	4-D11	6860	FLOOR MATS & PADS (COUPE)			
4-F06	6680	AUDIO SYSTEMS (RADIO & TAPE DECK) (COUPE)	4-K11	6860A	FLOOR MATS & PADS (CONVERTIBLE)			
4-K06	6680 A	AUDIO SYSTEMS (RADIO & TAPE DECK) (CONVERTIBLE)	4-C12	6870	SERVICE TOOLS			
4-M06	6682	AUDIO SYSTEMS (ANTENNA & SPEAKER) (COUPE)	4-D12	6900	VISORS,ASSIST HANDLES & MIRRORS (COUPE)			
4-D07	6682 A	AUDIO SYSTEMS (ANTENNA & SPEAKER) (CONVERTIBLE)	4-H12	6900A	VISORS,ASSIST HANDLES & MIRRORS (CONVERTIBLE)			
4-G07	6684	AUDIO SYSTEMS(NOISE SUPPRESSOR & EARTH CORD)	4-K12	6930	CAUTION PLATES & LABELS			
4-H07	6700	WIRING HARNESSSES(FRONT & REAR)	4-N12	7250	QUARTER WINDOW & TRIMS			
4-N07	6701	WIRING HARNESSSES(ENGINE & TRANSMISSION)	4-E13	7800	SPOILERS & RELATED PARTS			
4-D08	6702	WIRING HARNESSSES(DASHBOARD)	4-C14	7900	ACCESSORIES			

FROM-TO
-9113
-9113
9113-
9113-
1992-05

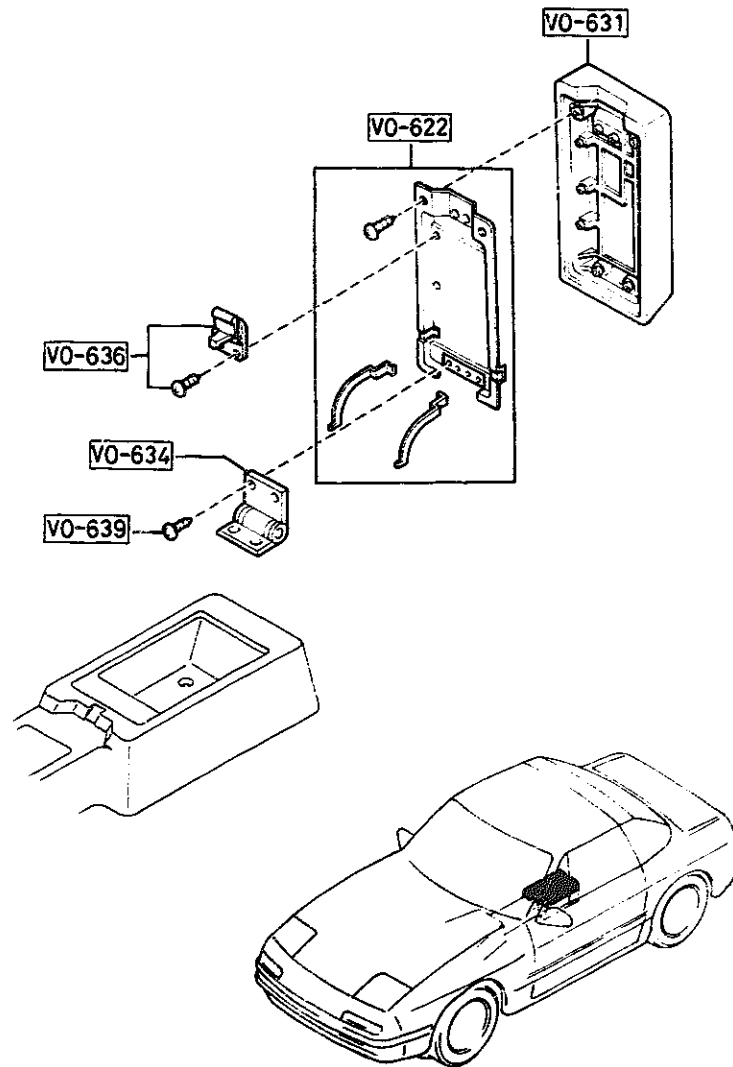

PART NO.	QTY	MODEL/RESTRICTION	MODEL/RESTRICTION	MODEL/RESTRICTION	FROM-TO
VO-622		LID, INNER			
FB01-VO-622	1	(CONVERTIBLE)			
VO-631		LID, OUTER			
FB01-VO-631	1	(CONVERTIBLE)			
OF		BLACK			
SF		BLUE			
VO-634		HINGE			
FB01-VO-634	1	(CONVERTIBLE)			
OF		BLACK			
SF		BLUE			
VO-636		LOCK PLATE			
FB01-VO-636	1	(CONVERTIBLE)			
VO-639		SCREW			
FB01-VO-639	1	(CONVERTIBLE)			

AUFA02

CAT. AUFA02-06

1992-05

4-C14