

This file is available for free download at <http://www.iluvmyrx7.com>

This file was not scanned to deprive Mazda of any money – it was scanned due to the rareness of the original manuals and the overwhelming need of the RX-7 owner to have this information so that they can accurately troubleshoot problems. Perhaps if Mazda's dealerships could support the Rotary Engine it wouldn't be so necessary for the owners to do so.



Many thanks to Anh Diep for scanning this file.

MANUAL TRANSMISSION

OUTLINE	7A— 2
SPECIFICATIONS.....	7A— 2
TROUBLESHOOTING GUIDE	7A— 2
ON-VEHICLE CHECK	7A— 3
REMOVAL AND INSTALLATION	7A— 4
NON TURBO MODEL	
DISASSEMBLY	7A— 5
INSPECTION.....	7A—12
ASSEMBLY.....	7A—15
INSTALLATION.....	7A—24
TURBO MODEL	
DISASSEMBLY	7A—25
HOUSING PARTS	7A—27
5TH/REVERSE GEAR	7A—32
MAINSHAFT	7A—35
INSPECTION.....	7A—38
ASSEMBLY.....	7A—41
INSTALLATION.....	7A—53

87U07A-0C1

7A OUTLINE, TROUBLESHOOTING GUIDE

OUTLINE

SPECIFICATIONS

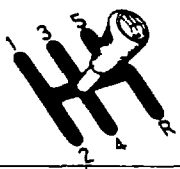
Model		Turbo	Non-turbo
Synchromesh system		Forward: Synchromesh Reverse: Constant-mesh	
Shift type			
Gear ratio	First	3.483	3.475
	Second	2.015	2.002
	Third	1.391	1.366
	Fourth	1.000	
	Fifth	0.762	0.697
	Reverse	3.288	3.493
Oil	Type	API Service GL-4 or GL-5 Outside temp. -18°C (0°F) or lower: SAE 80W Outside temp. -18°C (0°F) or higher: SAE 90 All season type: SAE 80W-90	
	Capacity liters (US qts, Imp. qts)	2.5 (2.6, 2.2)	2.0 (2.1, 1.8)

87U07A-002

TROUBLESHOOTING GUIDE

Problem	Possible Cause	Remedy
Abnormal noise	Insufficient oil Deterioration of oil quality Worn bearing Worn contact surface of counter shaft gear Worn contact surface of gears Excessive gear backlash Damaged gear teeth	Add oil Replace with specified oil Replace Replace Replace Replace Replace

77U07A-103

Problem	Possible Cause	Remedy
Jumps out of gear	Weak or broken lock ball spring Worn shift fork Worn clutch hub Worn clutch hub sleeve Worn gears Excessive gear backlash Worn bearing Loose engine or transmission mounts	Replace Replace Replace Replace Replace Replace Replace Tighten

87U07A-003

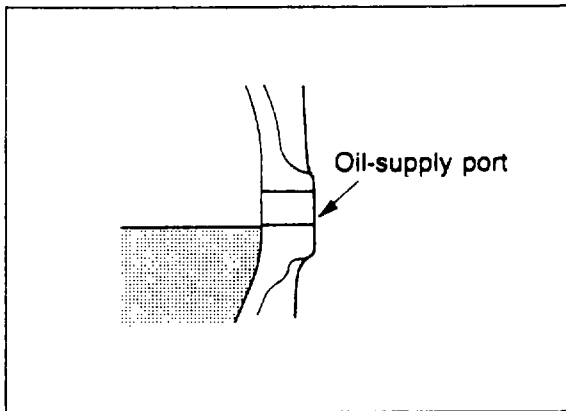

87U07A-004

ON-VEHICLE CHECK

(NON-TURBO MODEL) CHECKING TRANSMISSION OIL LEVEL

Remove the oil fill plug. Check that the oil is near the bottom of the hole.

If it is low, add the specified oil.

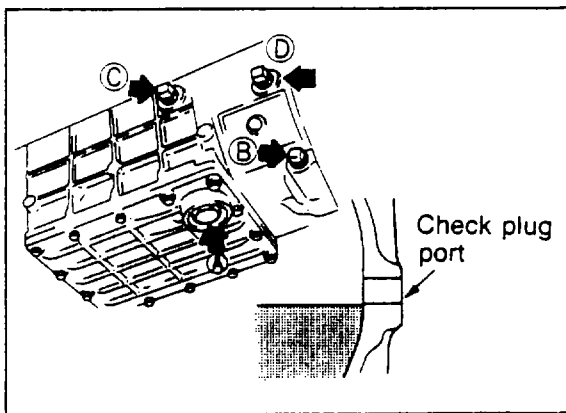

87U07A-005

(TURBO MODEL) CHECKING TRANSMISSION OIL LEVEL

Remove inspection plug D. Verify that the oil is near the bottom of the hole. If it is low, add specified oil from plug C port.

REPLACEMENT OF OIL

1. Remove the two drain plugs (A and B) and the two inspection plugs (C and D) and drain the oil into a suitable container.
2. Wipe the magnetic drain plugs clean.
3. After the oil has drained, apply sealant to the plug threads and install them.

Tightening torque:

- Ⓐ : 39—59 N·m
(4.0—6.0 m·kg, 29—43 ft·lb)
- Ⓑ : 25—39 N·m
(2.5—4.0 m·kg, 18—29 ft·lb)

4. Add oil from plug C port until it reaches the bottom of plug D hole.
5. Apply sealant to the threads of the inspection plugs and install them.

Tightening torque:

- 25—39 N·m (2.5—4.0 m·kg, 18—29 ft·lb)

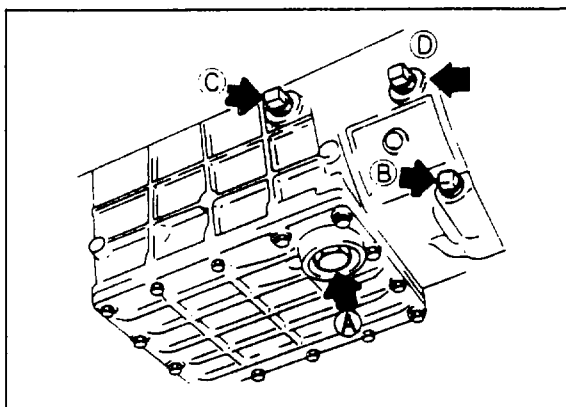

87U07A-006

7A REMOVAL AND INSTALLATION

REMOVAL AND INSTALLATION

1. Disconnect the negative battery cable.
2. Raise the vehicle and support it with stands.
3. Drain the transmission oil
4. Remove in the sequence shown in the figure.
5. Install in the reverse order of removal.

67U07A-005

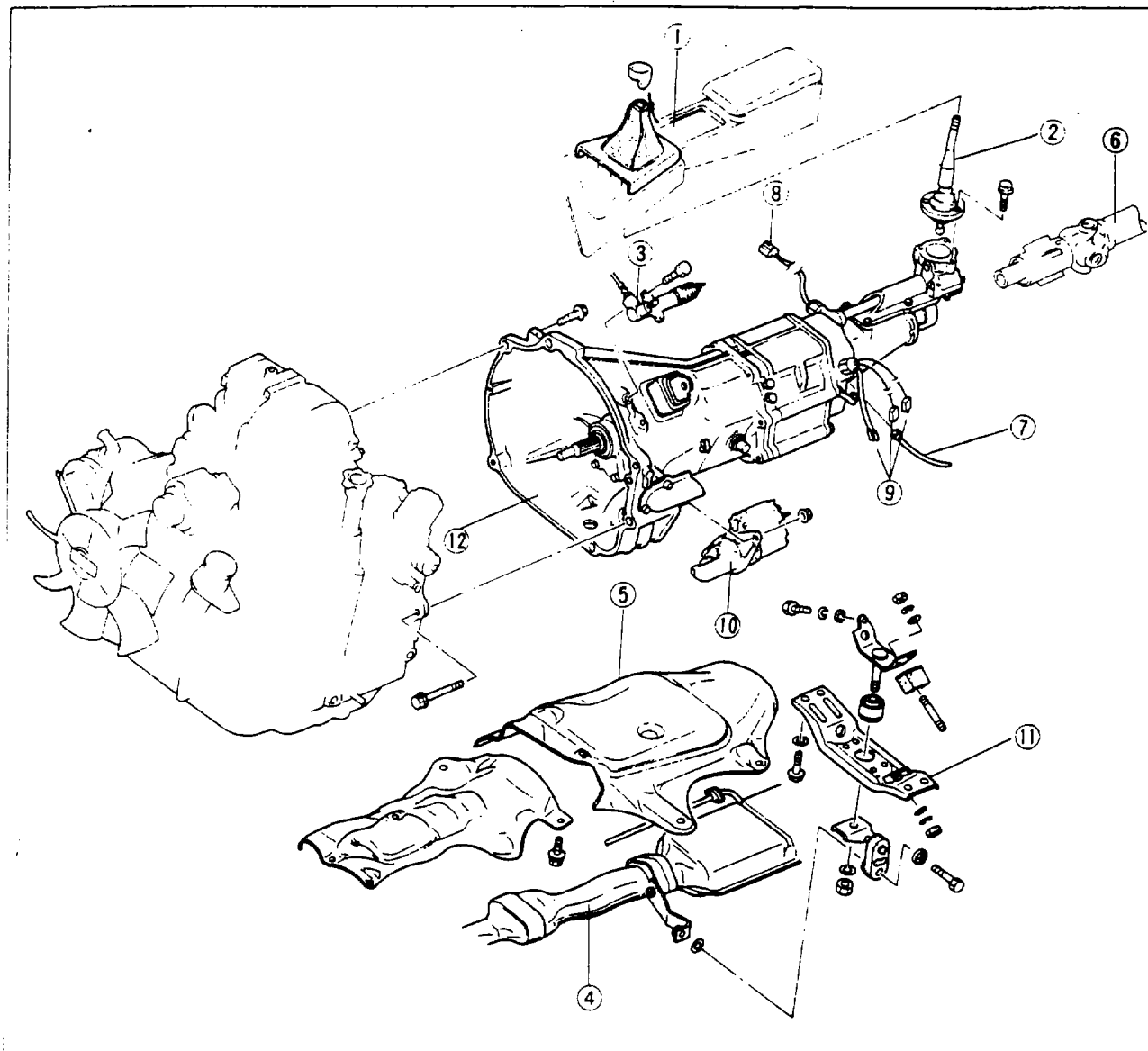

67U07A-006

- | | | |
|----------------------------|------------------------|---------------------------------|
| 1. Console box | 5. Covers | 9. Connector (5th/reverse gear) |
| 2. Gearshift lever | 6. Propeller shaft | 10. Starter |
| 3. Clutch release cylinder | 7. Speedometer cable | 11. Transmission crossmember |
| 4. Exhaust pipe | 8. Connector (neutral) | 12. Transmission |

DISASSEMBLY.....NON-TURBO

Disassemble in the sequence shown in the figure.

HOUSING PARTS

77U07A-105

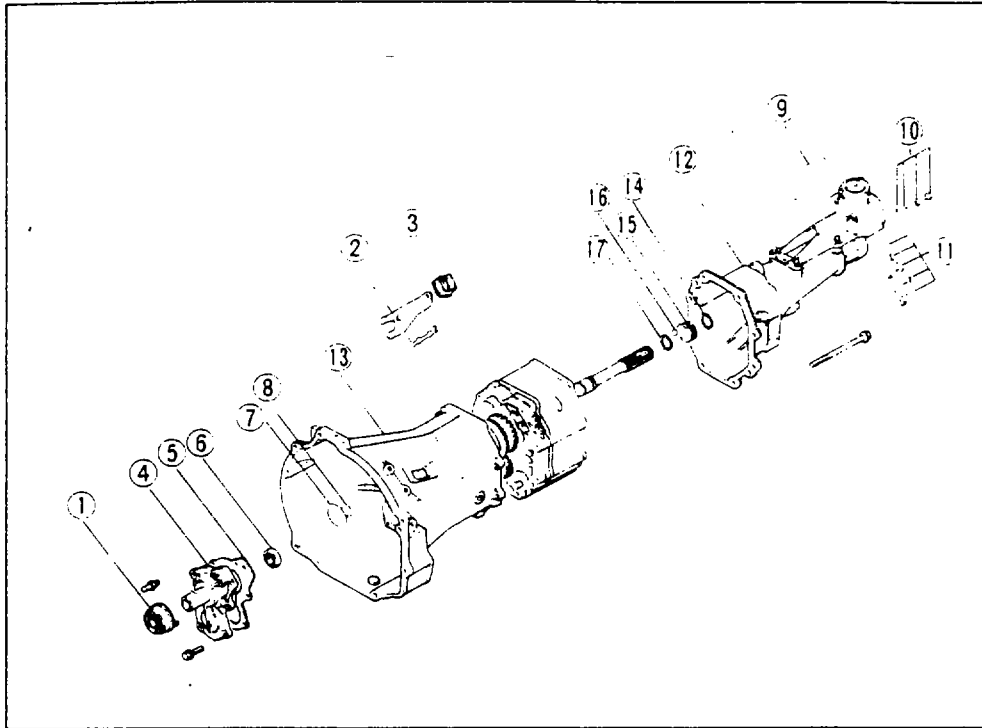

1. Release bearing
2. Release fork
3. Boot
4. Front cover
5. Gasket
6. Oil seal
7. Adjust shim(s)
8. Snap ring
9. Cover
10. Bolt, spring and lock ball
11. Cover and select lock spindle
12. Extension housing
13. Transmission case
14. Snap ring
15. Speedometer drive gear
16. Ball
17. Snap ring

67U07A 008

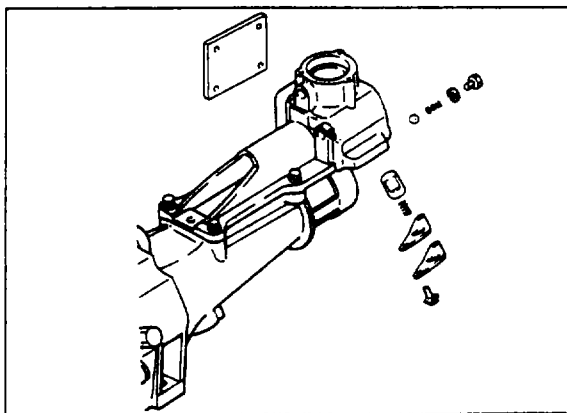

67U07A-009

Extension Housing

1. Remove the cap bolt, spring and lock ball.
2. Remove the cover, spring and select lock spindle.
3. Remove the control case cover.

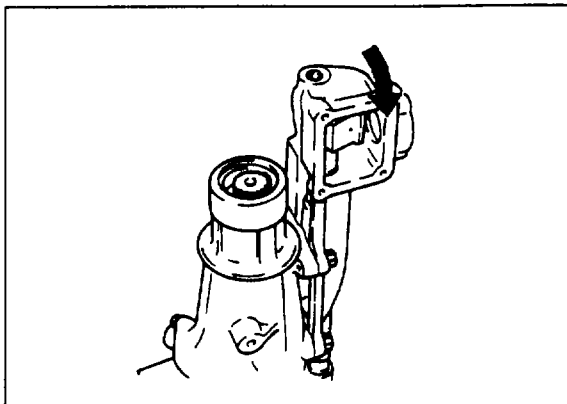

67U07A-010

4. Shift the transmission into 1st gear.
5. Remove the extension housing attaching bolts.
6. Remove the bolt attaching the control rod end to the control rod. **Do not** remove the control rod end.
7. Turn the control rod in the direction of the arrow and remove the extension housing.

7A DISASSEMBLY

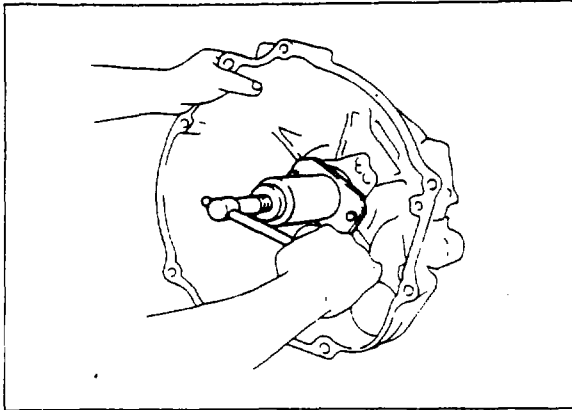

67U07A-011

Transmission Case

Remove the transmission case from the intermediate housing and gear assembly using the **mainshaft pusher** (49 0305 430).

SHIFT FORK AND SHIFT ROD

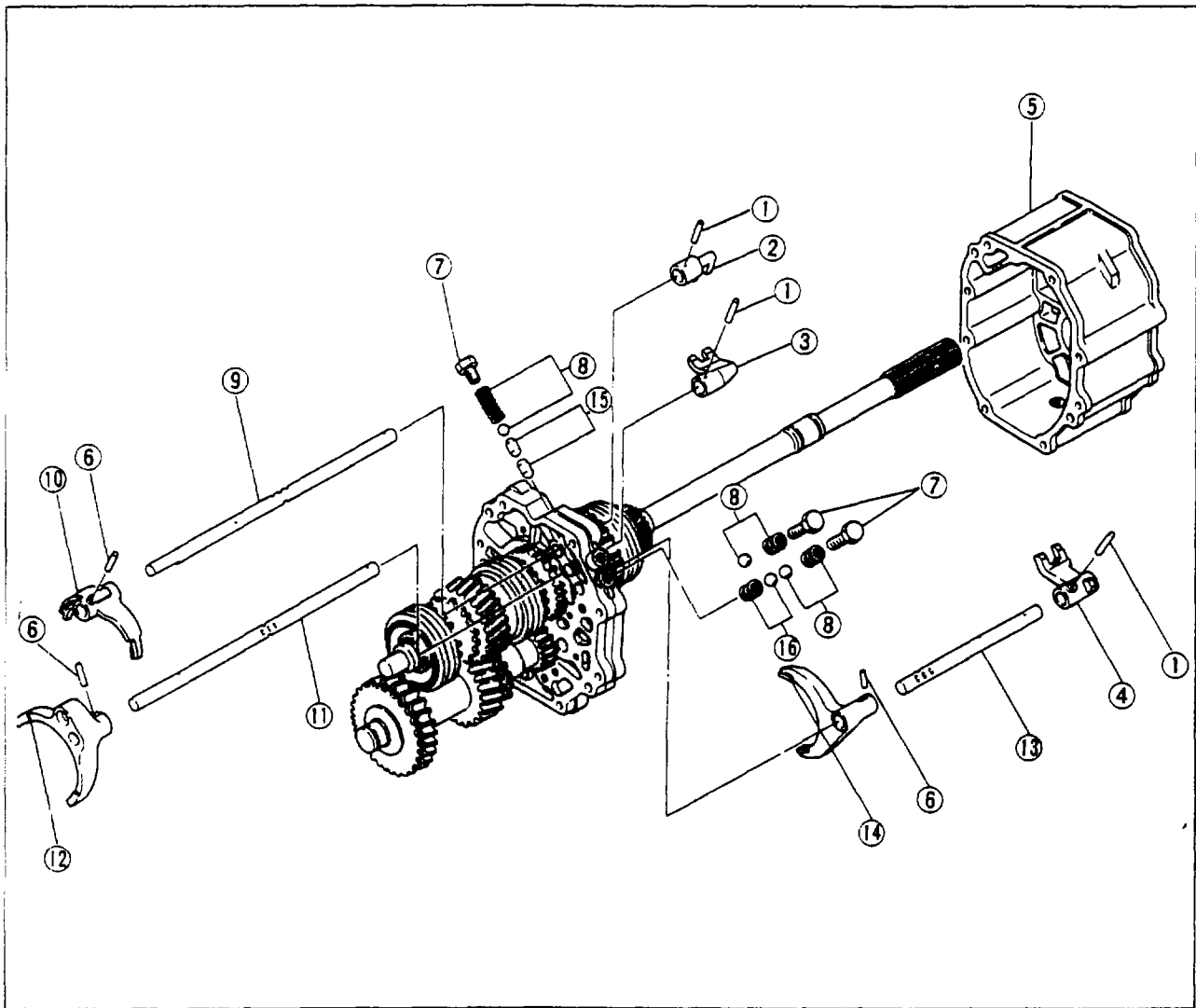

67U07A-012

- | | | |
|--------------------------------|--------------------------|------------------------------|
| 1. Spring pins | 6. Spring pins | 11. Shift rod (3rd/4th) |
| 2. Shift rod end (1st/2nd) | 7. Cap plugs | 12. Shift fork (3rd/4th) |
| 3. Shift rod end (3rd/4th) | 8. Springs and balls | 13. Shift rod (5th/reverse) |
| 4. Shift rod end (5th/reverse) | 9. Shift rod (1st/2nd) | 14. Shift fork (5th/reverse) |
| 5. Intermediate housing | 10. Shift fork (1st/2nd) | 15. Interlock pins |
| | | 16. Ball and spring |

MAINSHAFT AND COUNTERSHAFT

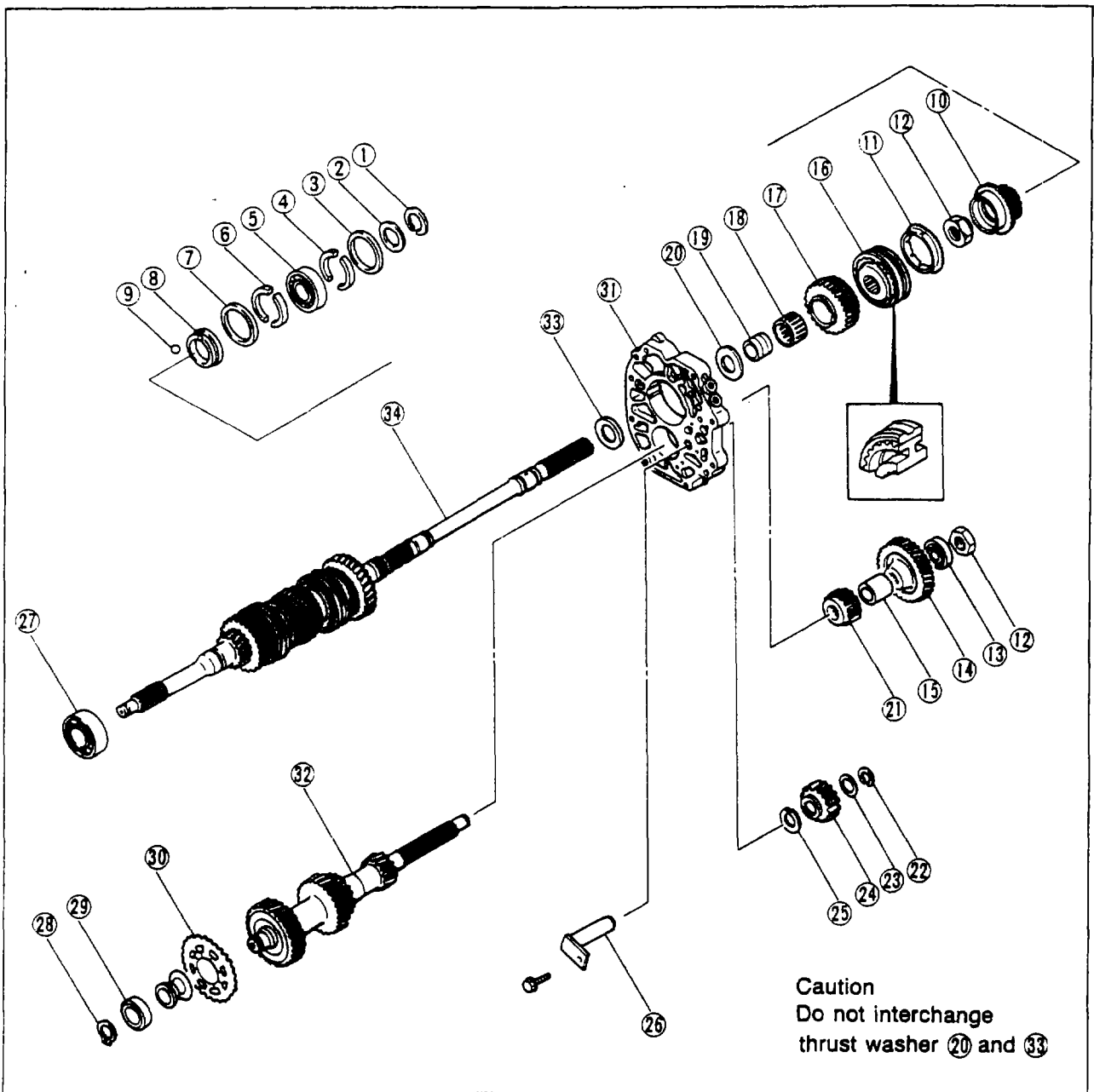

77U07A-106

- | | | |
|---------------------------|---------------------------------------|---------------------------------|
| 1. Snap ring | 13. Ball bearing | 24. Reverse idle gear |
| 2. Washer | 14. Countergear | 25. Thrust washer |
| 3. Retaining ring | 15. Spacer | 26. Reverse idle gear shaft |
| 4. "C" washers | 16. Clutch hub assembly (5th/reverse) | 27. Main drive gear bearing |
| 5. Mainshaft rear bearing | 17. Reverse gear | 28. Snap ring |
| 6. "C" washers | 18. Needle bearing | 29. Bearing |
| 7. Retaining ring | 19. Inner race | 30. Friction gear |
| 8. Thrust lock washer | 20. Washer | 31. Bearing housing assembly |
| 9. Ball | 21. Counter reverse gear | 32. Countershaft gear |
| 10. 5th gear | 22. Snap ring | 33. Thrust washer |
| 11. Synchronizer ring | 23. Adjust washer | 34. Mainshaft and gear assembly |
| 12. Lock nut | | |

7A DISASSEMBLY

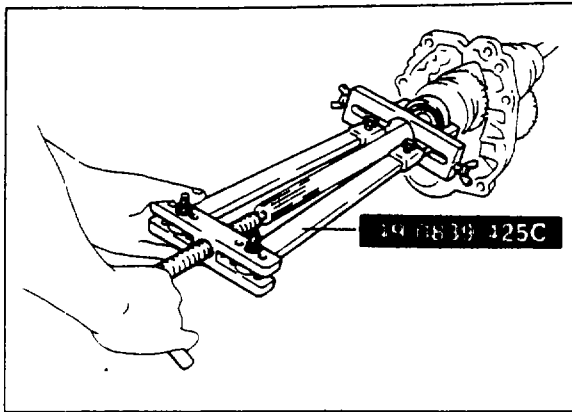

67U07A-014

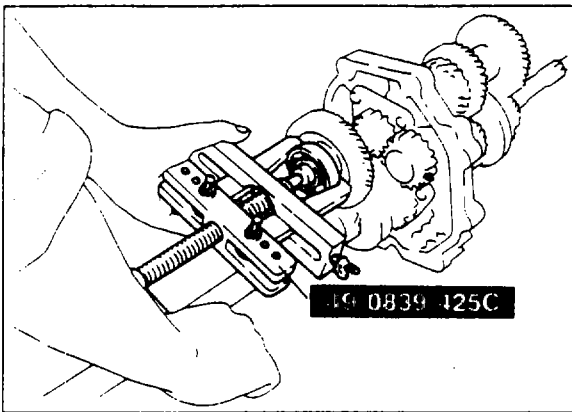

67U07A-015

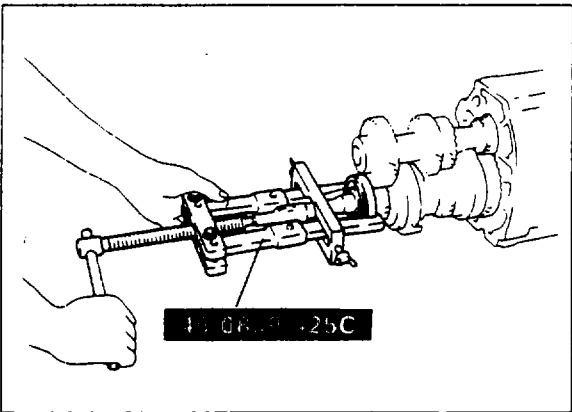

67U07A-016

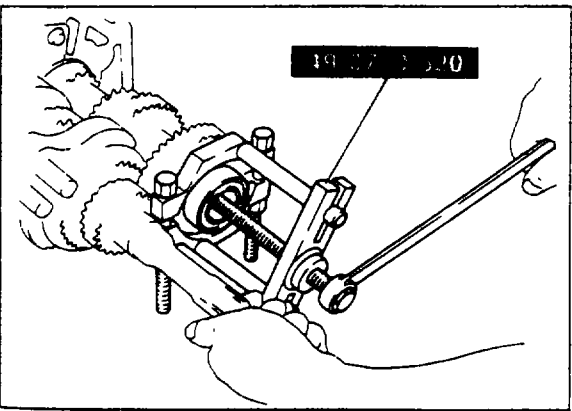

67U07A-017

Bearing

1. Remove the snap ring, washer, retaining ring, and "C" washers, then remove the mainshaft rear bearing using **puller** (49 0839 425C).

2. Remove the lock nut (see page 7A—9), then remove the countershaft rear bearing using **puller** (49 0839 425C).

3. Remove the main drive gear bearing using **puller** (49 0839 425C).

4. Remove the countershaft bearing using **bearing puller** (49 0710 520).

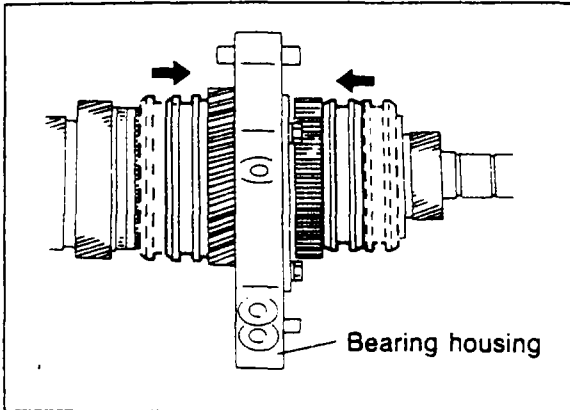

4BG07X-011

Lock Nut

1. Shift the clutch hub sleeves to first gear and reverse gear to put the gears in the double-engaged condition.

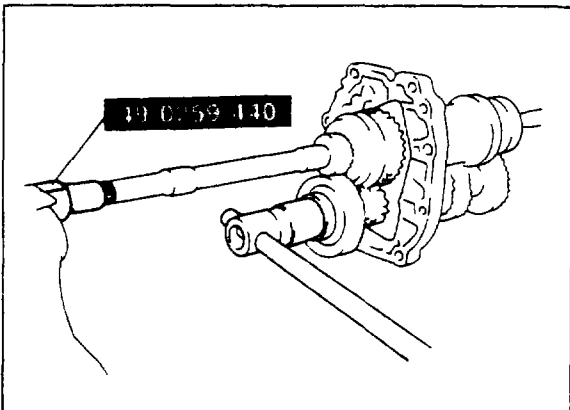

67U07A-018

2. Counter shaft lock nut
 - 1) Connect the **mainshaft holder** (49 0259 440) to the mainshaft, and mount securely in a vise.
 - 2) Remove the lock nut.

Caution

Do not re-use the lock nut.

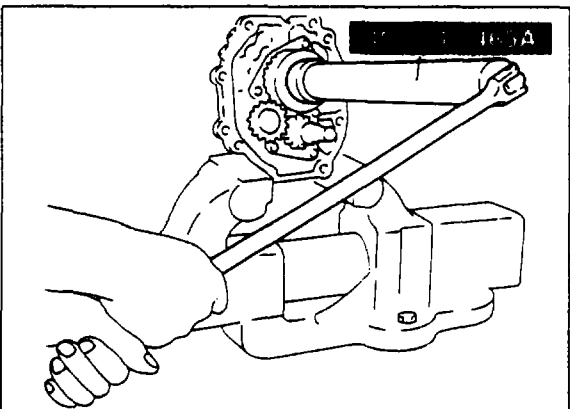

67U07A-019

3. 5th/reverse clutch hub lock nut.
 - 1) Uncrimp the tabs of the lock nut.
 - 2) Secure the bearing housing in a vise.
 - 3) Remove the lock nut using **lock nut wrench** (49 1243 465A).

Caution

- a) **Do not re-use the lock nut after it has been removed.**
- b) **Use pads in the vise.**

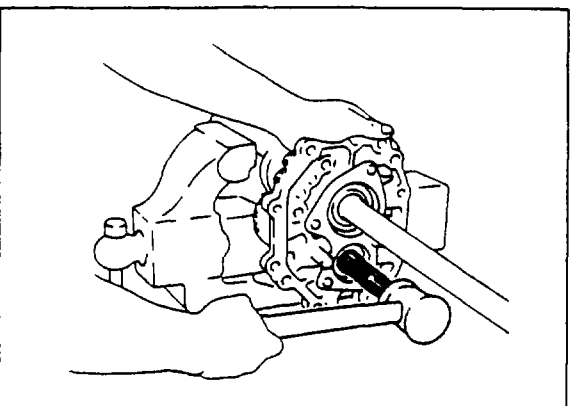

67U07A-020

Center Bearing Housing Assembly

Remove the bearing housing by lightly tapping the countershaft and mainshaft with a copper hammer.

7A DISASSEMBLY

MAINSHAFT

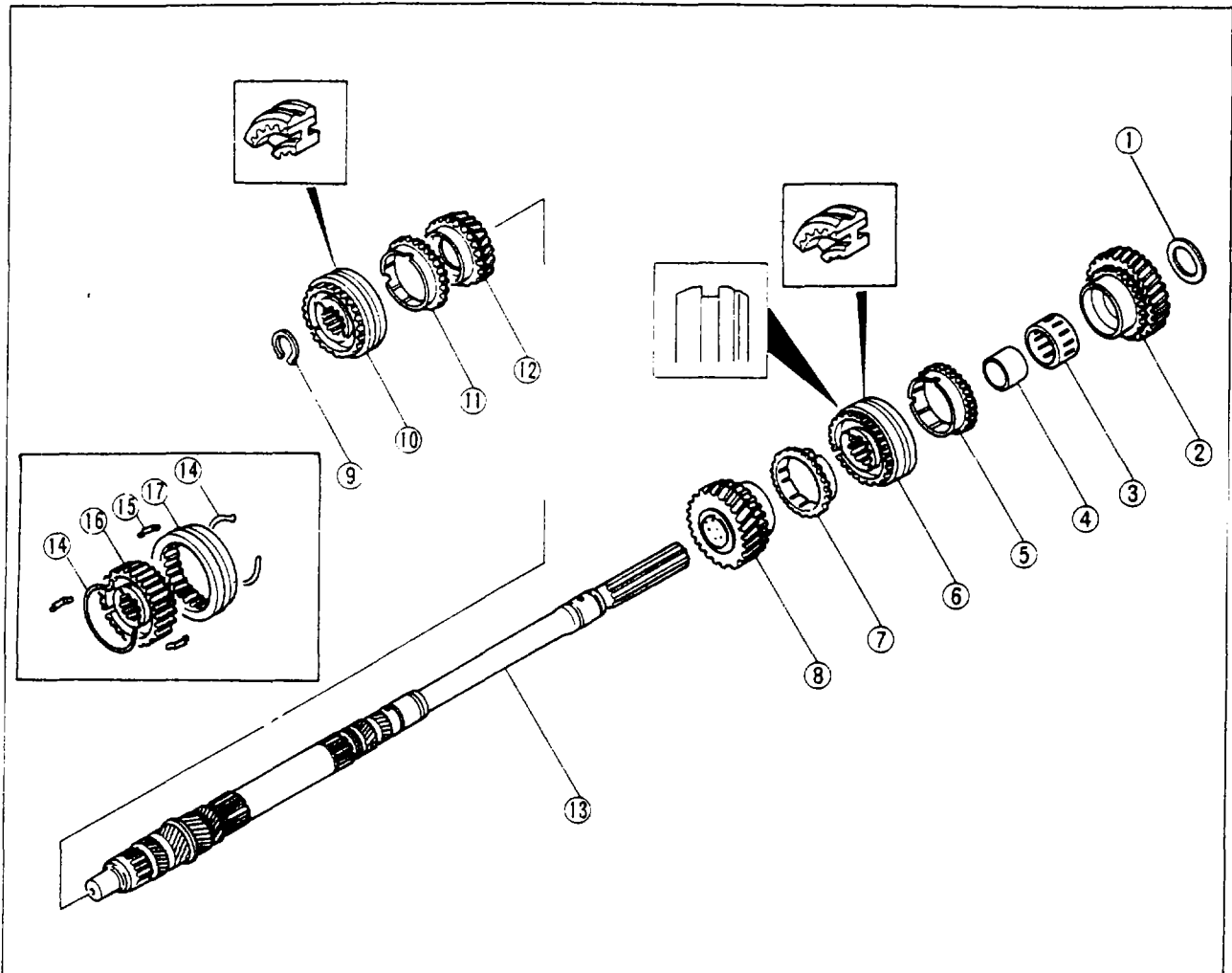

67U07A-021

- | | | |
|----------------------------------|-----------------------------------|------------------------------|
| 1. Washer | 7. Synchronizer ring (2nd) | 13. Mainshaft |
| 2. 1st gear | 8. 2nd gear | 14. Synchronizer key springs |
| 3. Needle bearing | 9. Snap ring | 15. Synchronizer key |
| 4. Inner race | 10. Clutch hub assembly (3rd/4th) | 16. Clutch hub |
| 5. Synchronizer ring (1st) | 11. Synchronizer ring (3rd) | 17. Clutch hub sleeve |
| 6. Clutch hub assembly (1st/2nd) | 12. 3rd gear | |

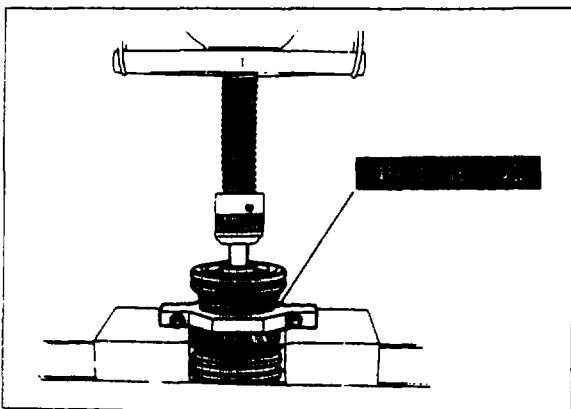

67U07A-022

Clutch Hub Assembly

1. Place the **pulley boss puller** (49 0636 145) between 2nd gear and 3rd gear.
2. Support the mainshaft by hand to prevent it from falling, and press on the clutch hub assembly.

BEARING HOUSING

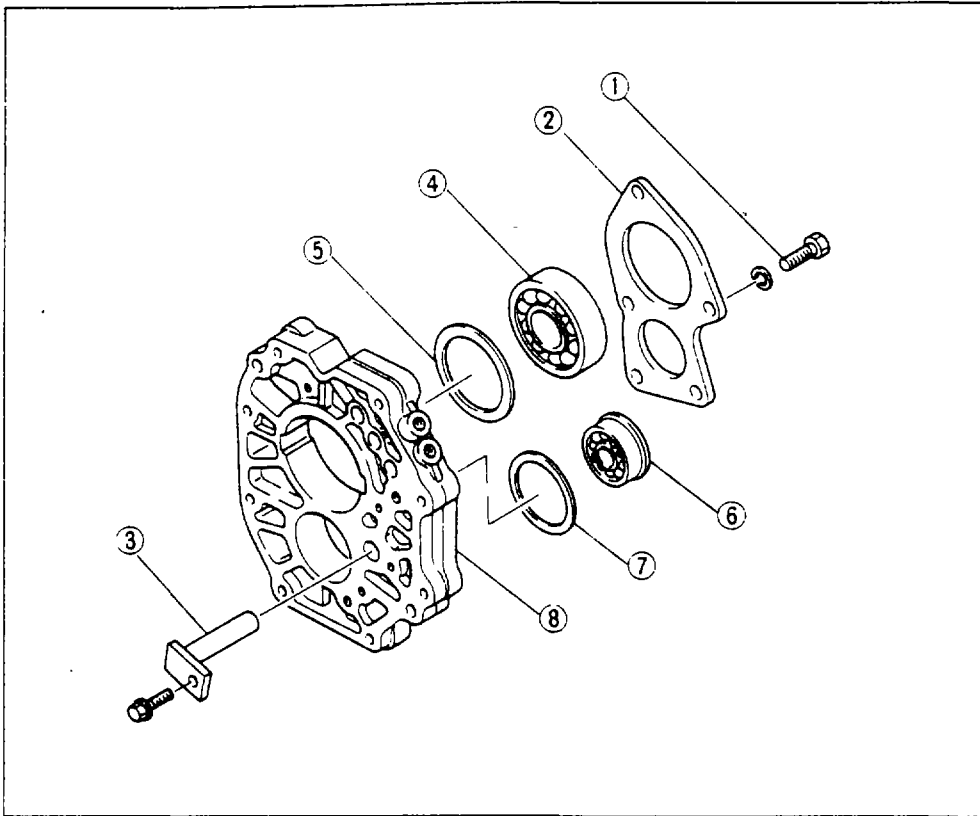

1. Bolt
2. Bearing cover
3. Reverse idle gear shaft
4. Ball bearing
5. Adjust shim
6. Ball bearing
7. Adjust shim
8. Bearing housing

67U07A-023

EXTENSION HOUSING

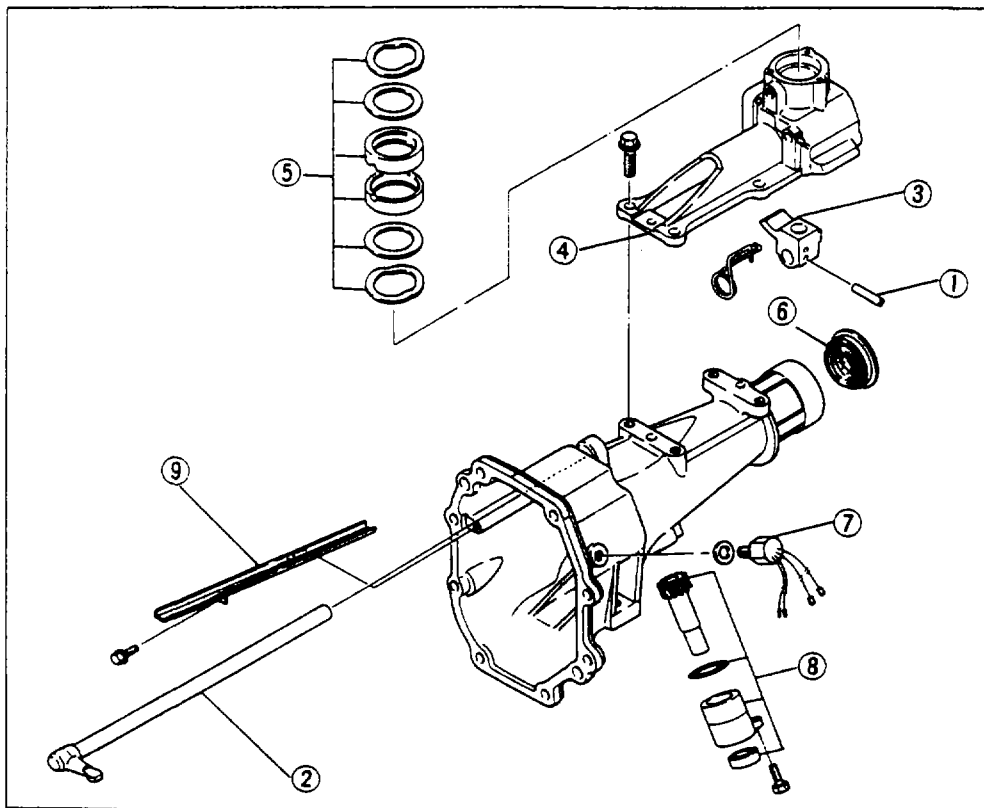

1. Pin
2. Control lever
3. Control rod end
4. Change control case
5. Change lever bush set
6. Oil seal
7. Back up lamp and 5th switch
8. Speedometer driven gear
9. Oil passage

67U07A-024

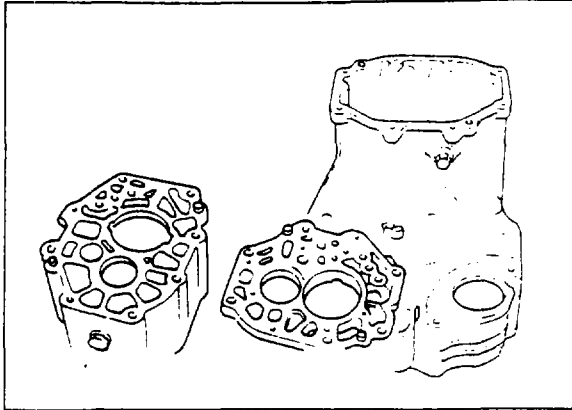

77U07A-107

INSPECTION

Check each of the items listed below, repair or replace if necessary.

Transmission Case and Housing

1. Cracked or damaged.
2. Rough or damaged contact surfaces.
3. Worn or damaged extension housing bushing or oil seal.

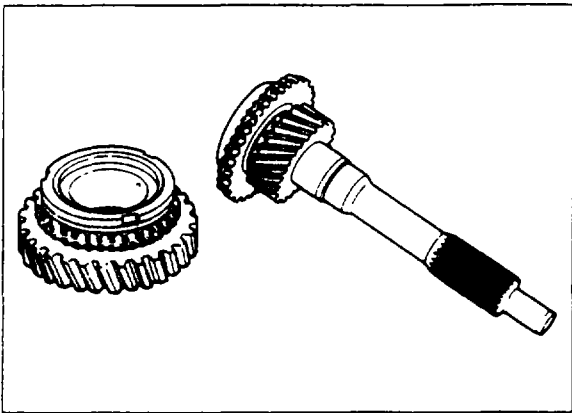

77U07A-108

Each Gear and Main Drive Gear

1. Worn or damaged synchronizer cones.
2. Worn or damaged hub sleeve parts.
3. Worn or damaged teeth.
4. Worn or damaged inner gear or outer gear surfaces.
5. Worn or damaged main drive shaft splines.

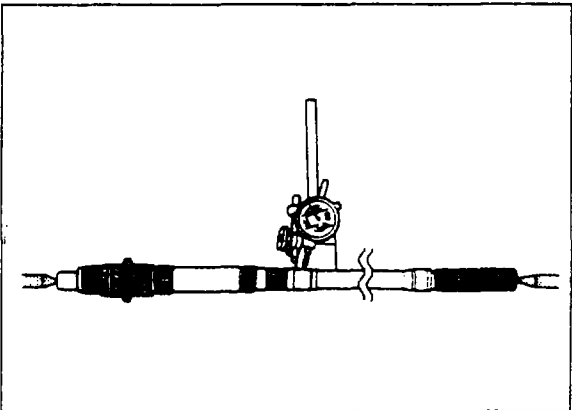

77U07A-109

Mainshaft

1. Deflection.

Deflection: 0.03 mm (0.0001 in) max.

2. Worn or damaged splines.

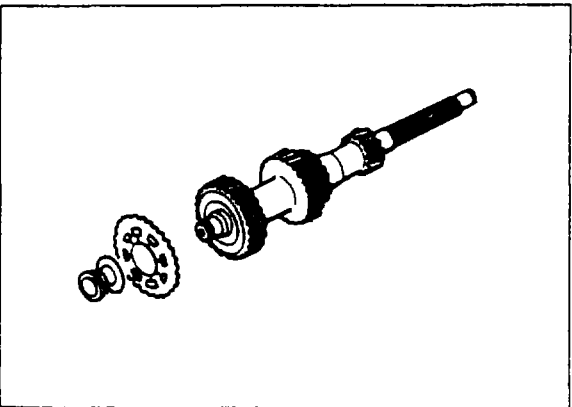

77U07A-110

Countershaft

1. Worn or damaged gear teeth.
2. Worn or damaged splines.
3. Worn or damaged friction gears.

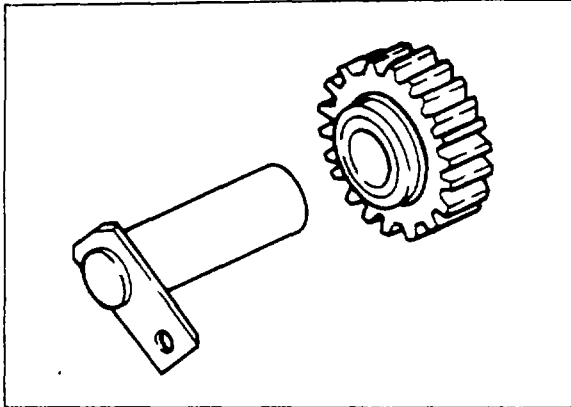

77U07A-111

Reverse Idle Gear and Shaft

1. Worn or damaged gear.
2. Worn shaft.

Standard clearance:

0.02—0.05 mm (0.0008—0.0020 in)

Max: 0.15 mm (0.0059 in).

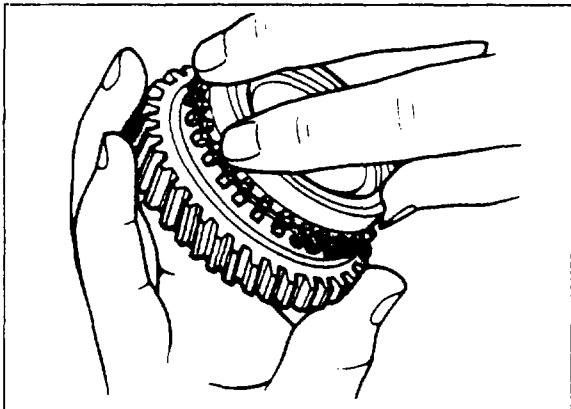

77U07A-112

Synchronizer Ring

1. Gear cone mesh.
2. Worn or damaged splines.
3. Worn or damaged taper surface.

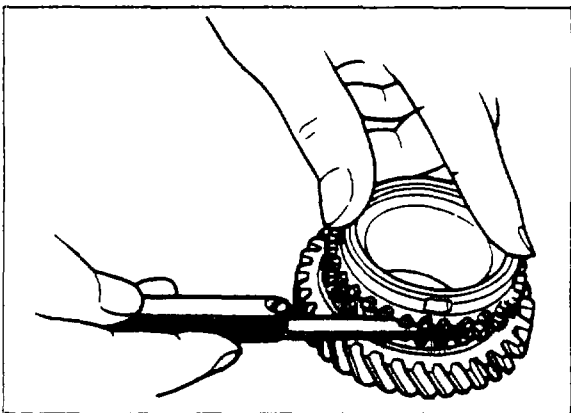

77U07A-113

4. Clearance between synchronizer ring and flank surface of gear.

Standard clearance: 1.5 mm (0.059 in)

Max: 0.8 mm (0.031 in)

Note

Set the synchronizer ring straight in the gear, and measure around the circumference.

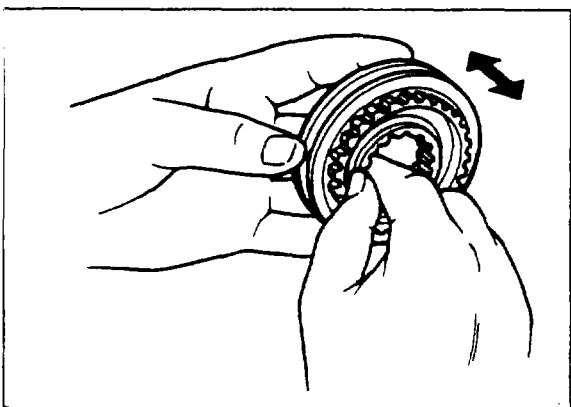

77U07A-114

Clutch Hub

1. Operation of clutch hub sleeve and hub.
2. Worn or damaged hub sleeve sliding surface.
3. Worn or damaged hub synchronizer key groove.
4. Worn gear teeth.

7A INSPECTION

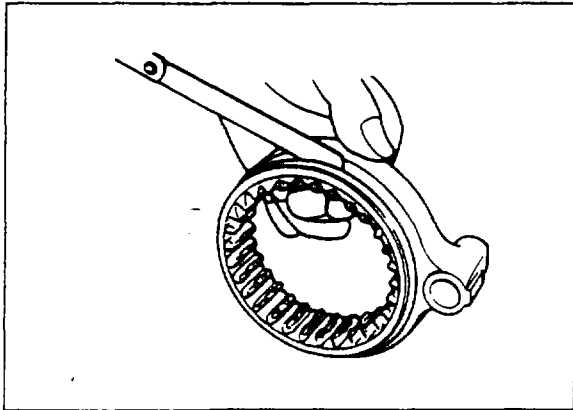

77U07A-115

Clutch Hub Sleeve

1. Worn or damaged clutch hub sliding surfaces.
2. Clearance between hub sleeve and release fork.

Standard clearance:

0.2—0.3 mm (0.008—0.012 in)

Max: 0.8 mm (0.031 in)

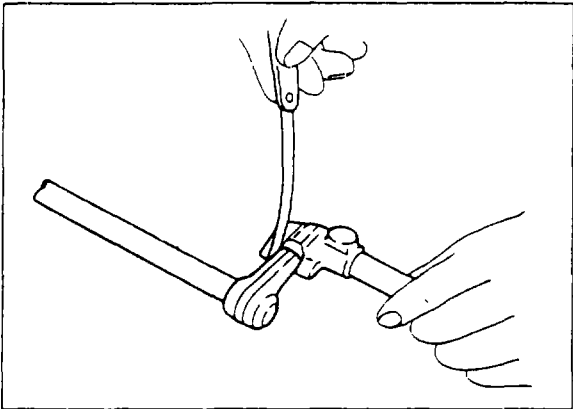

67U07A-034

Control Lever and Shift Rods

1. Clearance between the control lever and the gate of the shift rod.

Clearance: 0.8 mm (0.0315 in) max.

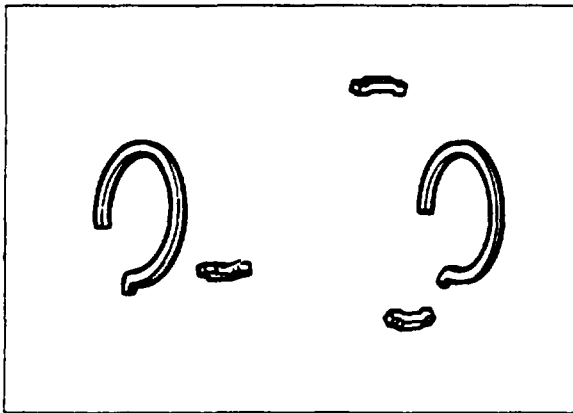

77U07A-116

Synchronizer Key and Key Spring

1. Worn key.
2. Fatigued or damaged spring.

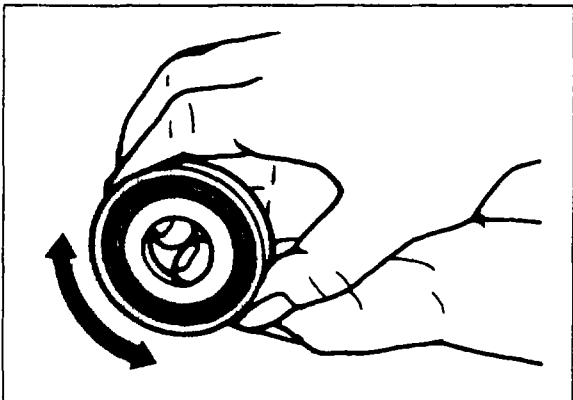

77U07A-117

Bearing

1. Roughness or noise while turning.
2. Damaged bearing.
3. Worn bearing.

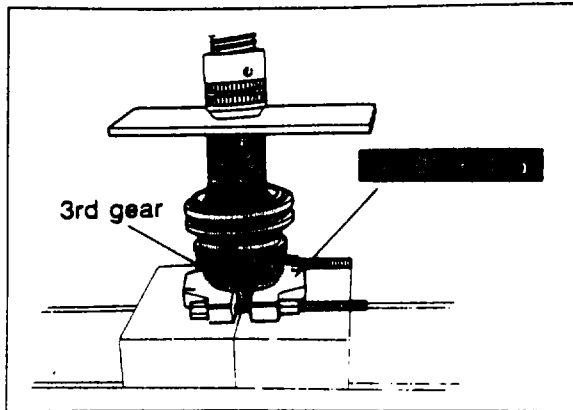

67U07A-037

ASSEMBLY

Clutch Hub

1. Place the 3rd gear and synchronizer ring on the mainshaft.
2. Press the clutch hub assembly (3rd/4th) on using a suitable pipe and **pulley boss puller** (49 0636 145).

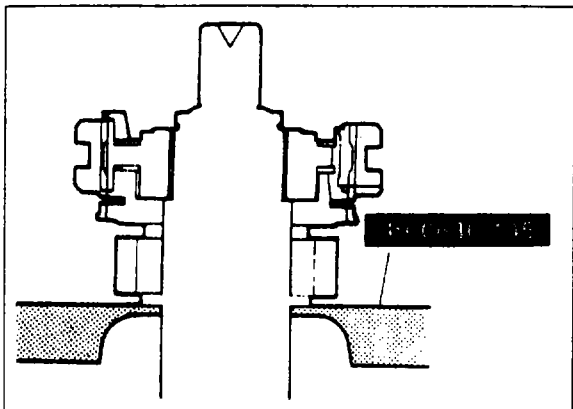

67U07A-038

Caution
Align the synchronizer ring and clutch hub when installing.

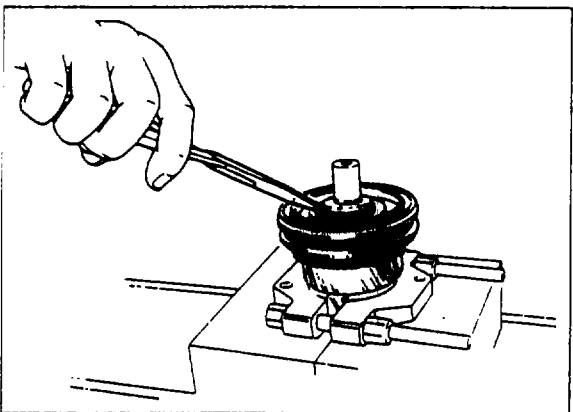

67U07A-039

3. Insert the snap ring using snap ring pliers.

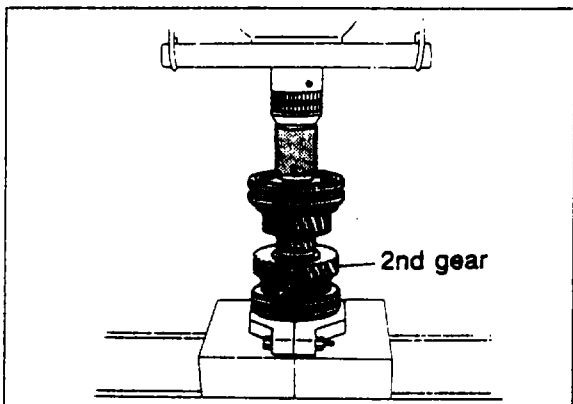

67U07A-040

4. After mounting the 2nd gear and synchronizer ring on the mainshaft, use a suitable piece of pipe to press the clutch hub assembly (1st/2nd) on.

Caution
Align the synchronizer ring and clutch hub when installing.

7A ASSEMBLY

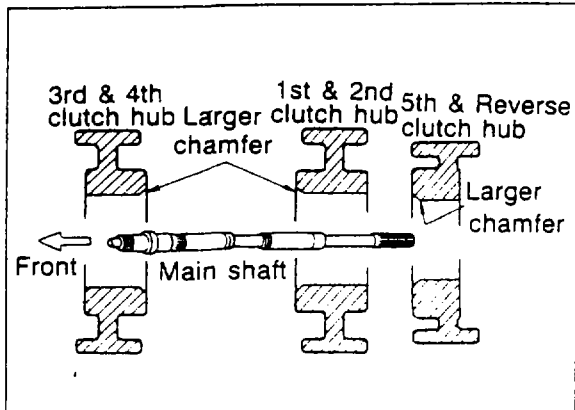

67U07A-041

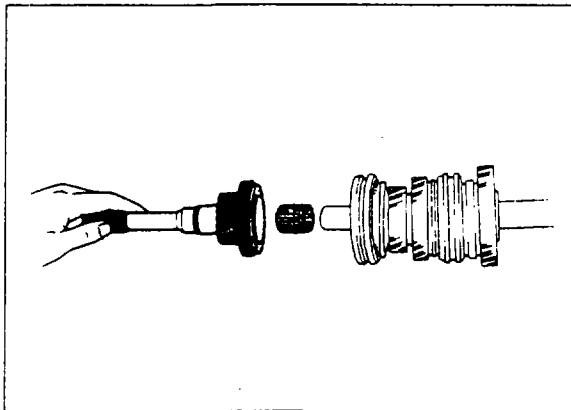

48G07A-031

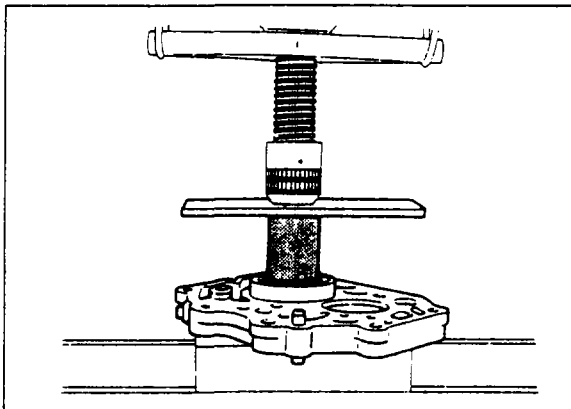

67U07A-042

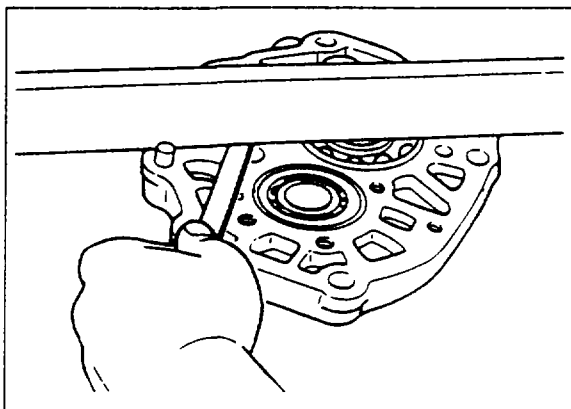

67U07A-043

Note

Press each clutch hub assembly on to the mainshaft in the proper direction.

5. Assemble the gear sleeve, 1st gear and washer to the mainshaft, install the needle bearing, synchronizer ring and main drive gear.

Bearing Housing

1. Use a suitable piece of pipe to press the bearing into the bearing housing.
2. Measure the clearance between the bearing and the bearing housing. If the clearance is not as specified, adjust it by using an adjust shim(s).

Standard clearance:

$0 \pm 0.05 \text{ mm}$ ($0 \pm 0.002 \text{ in}$)

Adjust shim:

0.1 mm (0.004 in), 0.3 mm (0.012 in)

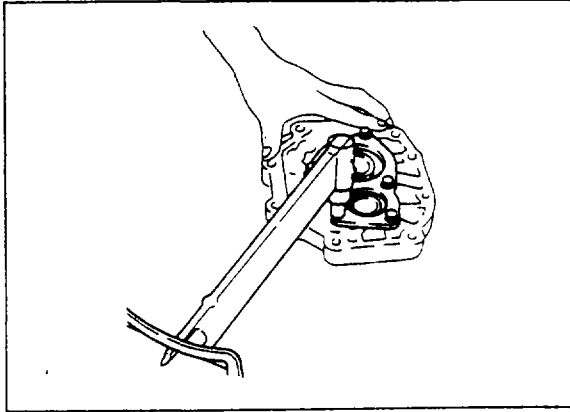

67U07A-044

3. Install the bearing cover to the bearing housing.

Tightening torque:

Bearing cover

18—26 N-m (1.8—2.7 m-kg, 13—20 ft-lb)

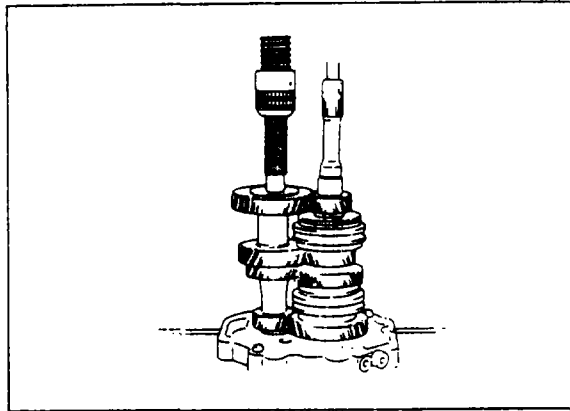

67U07A-045

4. Install the mainshaft and main drive gear assembly and the countershaft gear.
Use a suitable round bar to press in the countershaft.

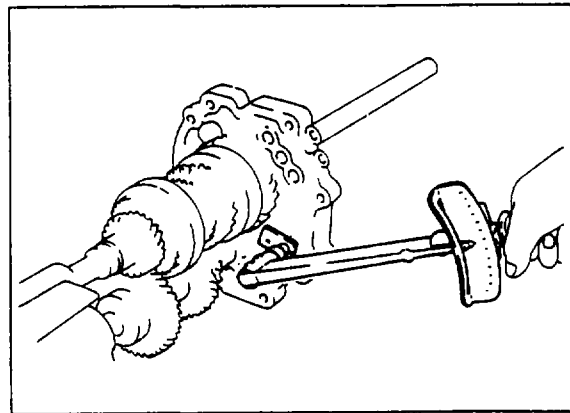

67U07A-046

Reverse Idle Gear

1. Mount the reverse idle gear and 2 washers to the reverse idle gear shaft.

Tightening torque:

9—13 N-m (90—130 cm-kg, 78—113 in-lb)

2. Install the washer, reverse gear and counter reverse gear.

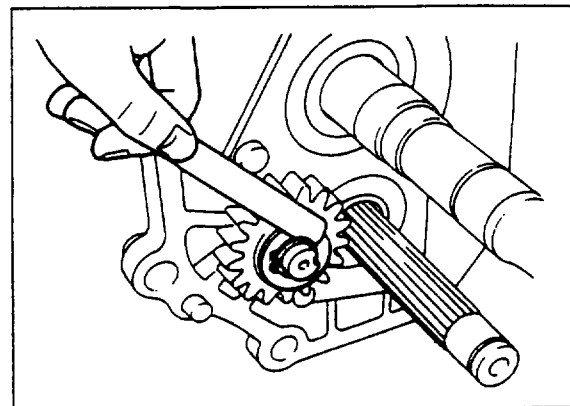

67U07A-047

3. Install the reverse idle gear shaft in the bearing housing.
4. Install the thrust washer, reverse idle gear, adjust washer and secure with the snap ring.
5. Measure the clearance between the adjust washer and snap ring.
6. If the clearance is not as specified, adjust with an adjust washer.

Standard clearance: 0.1 mm (0.004 in) max.

Adjust washer thickness:

2.1 mm (0.083 in), 2.2 mm (0.087 in)
2.3 mm (0.091 in), 2.4 mm (0.094 in)

7A ASSEMBLY

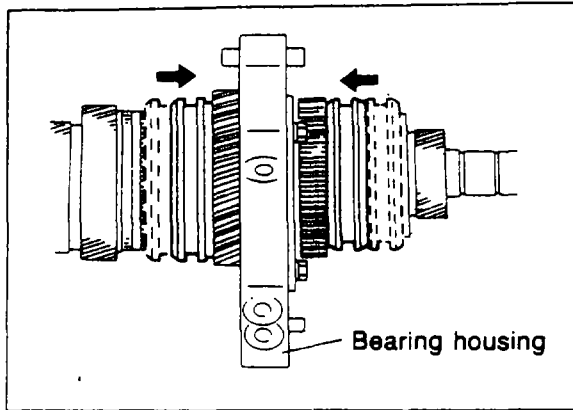

67U07A-048

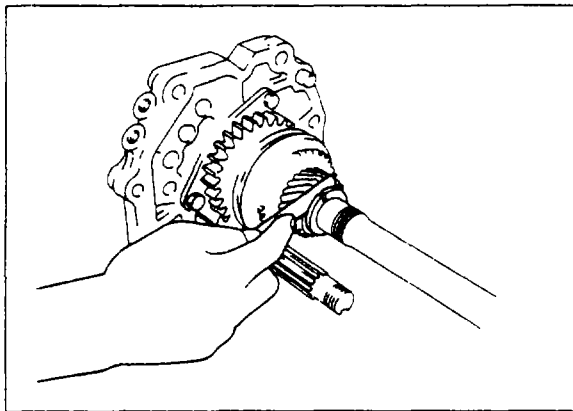

67U07A-049

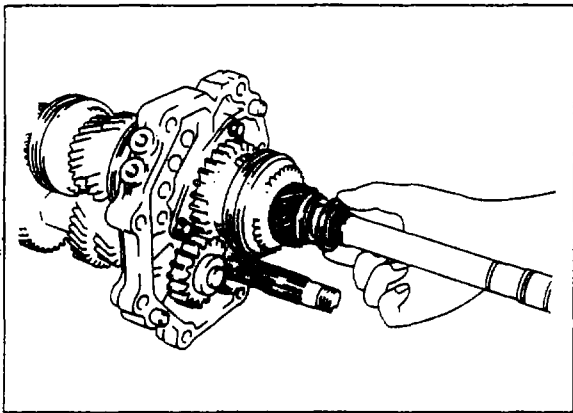

67U07A-050

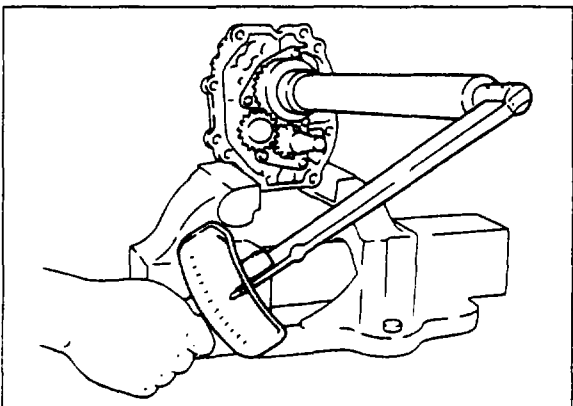

67U07A-051

Mainshaft Lock Nut

1. Install the clutch hub assembly and reverse idle gear.
2. Shift the clutch hub sleeves to first gear and reverse gear to put the gears in the double-engaged condition

3. Secure the bearing housing in a vise.
4. Tighten the new lock nut using the **lock nut wrench** (49 1243 465A).

Tightening torque:

130—210 N·m (13—21 m·kg, 94—152 ft·lb)

5. Stake the lock nut.

5th Gear

1. Install the 5th gear and synchronizer ring.
2. Insert the ball and thrust lock washer.
3. Install the "C" washers and hold them with the retaining ring.

Caution

- a) Use the 3.0 mm (0.118 in) "C" washers, or else the rear "C" washer may not be able to be installed.
- b) The two "C" washers must be the same thickness; a difference in thickness will cause bearing failure.

4. Measure the clearance between the thrust lock washer and "C" washers (5th gear end play). If the end play is not as specified, adjust with a thrust lock washer.

Standard play:

0.1—0.3 mm (0.004—0.012 in)

Thrust lock washer thickness:

- 6.4 mm (0.252 in)
- 6.5 mm (0.256 in)
- 6.6 mm (0.260 in)
- 6.7 mm (0.264 in)

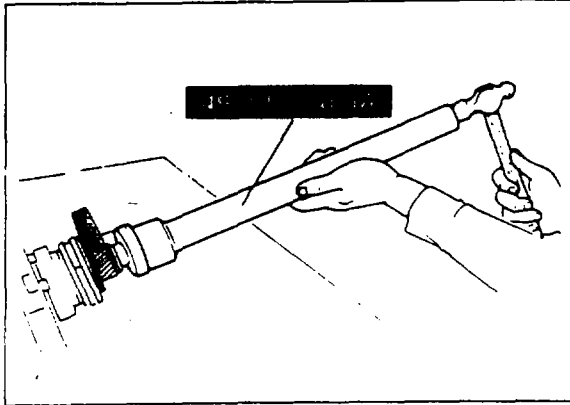

67U07A-052

Bearing

1. Drive on the main drive gear bearing using the **lock nut wrench** (49 1243 465A), then install the "C" washers, retaining ring and washer and secure them with the snap ring.

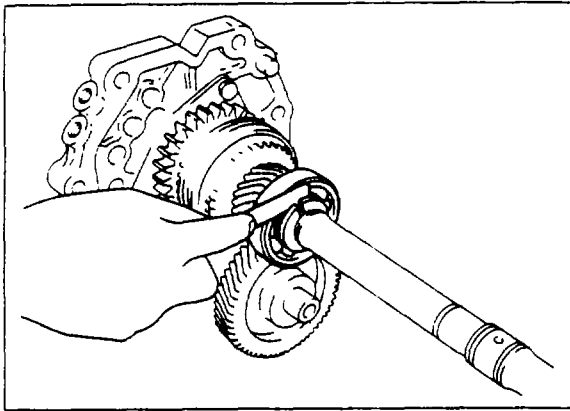

67U07A-053

2. Measure the clearance between the "C" washers and washer. If end play is not as specified, adjust the end play with other "C" washers.

Standard play: 0.3 mm (0.012 in) max.

"C" washer thickness:

2.9 mm (0.114 in), 3.0 mm (0.118 in)

3.1 mm (0.122 in), 3.2 mm (0.126 in)

Caution

Check that there is no clearance between the bearing and "C" washers.

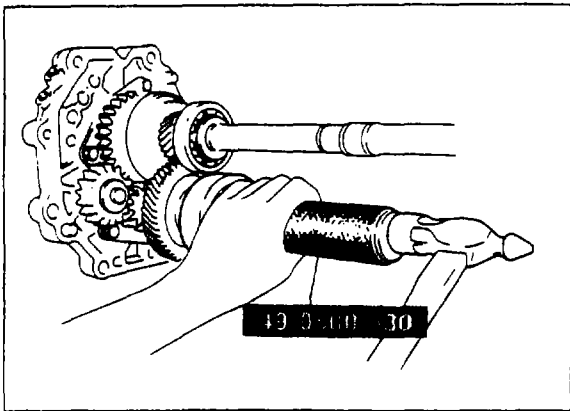

67U07A-054

3. Drive the ball bearing on the counter shaft using the **bearing installer** (49 0500 330).

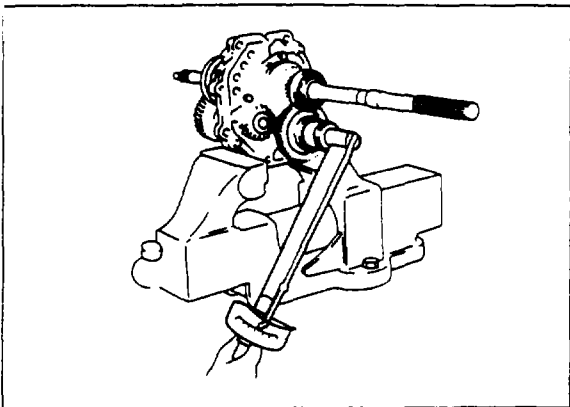

67U07A-055

Countershaft Lock Nut

1. Shift the clutch hub sleeves to first gear and reverse gear to put the gears in the double-engaged condition.
 - (1) Install the **mainshaft holder** (49 0259 440) on the mainshaft, and place in a vise.
 - (2) Tighten the lock nut.

Tightening torque:

127—196 N-m (13—20 m-k, 94—145 ft-lb)

7A ASSEMBLY

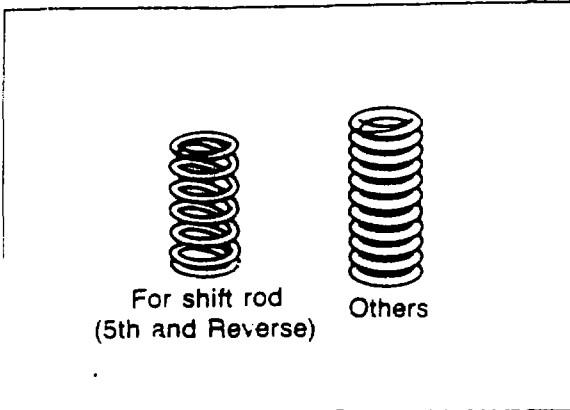

67U07A-056

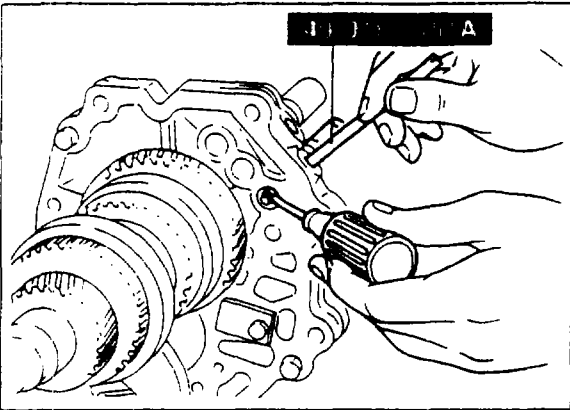

67U07A-057

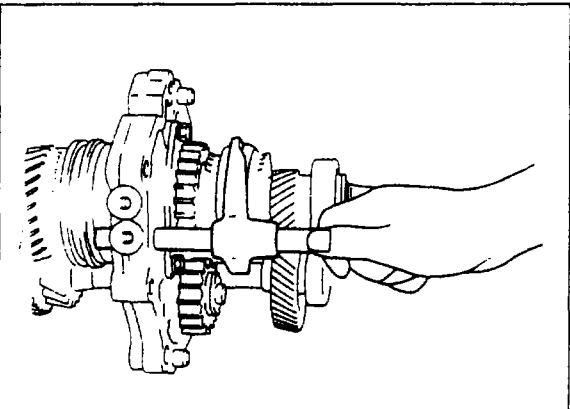

67U07A-058

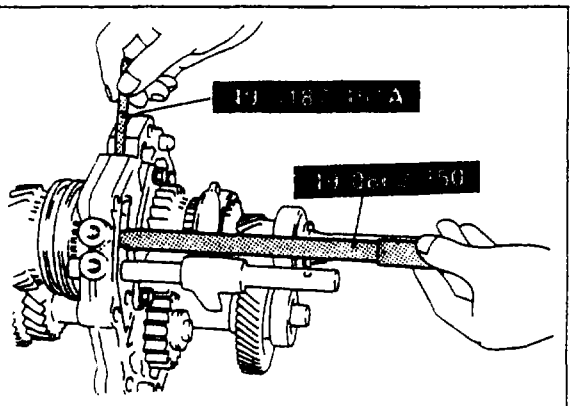

67U07A-059

Shift Fork and Rod

1. Insert the spring and ball (5th/reverse) into the bearing housing.

Note

There are 2 types of springs; be sure to install them correctly.

2. Press the spring and ball (5th/reverse) using the **interlock pin guide** (49 0187 451A) and a flat-tip screwdriver to install the shift rod.

3. Install the shift rod in the bearing housing.

4. Position the interlock pin in the bearing housing using the **shift fork guide** (49 0862 350) and **interlock pin guide** (49 0187 451A).

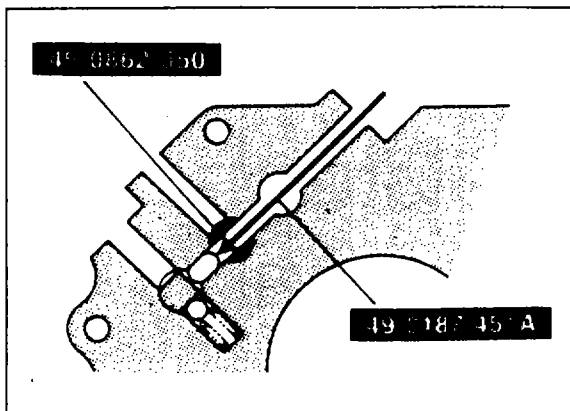

67U07A-060

5. Check that the interlock pin is correctly installed.

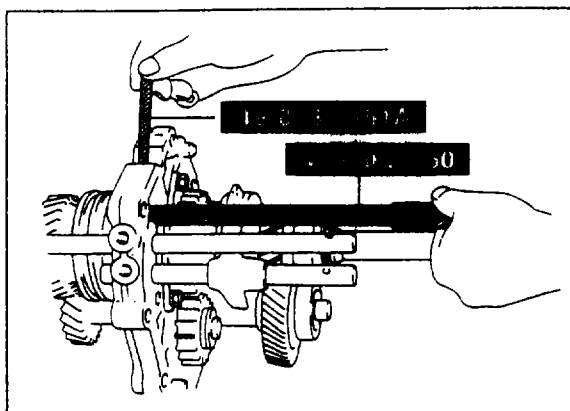

67U07A-061

6. Install the shift fork and rod (3rd/4th), and install the interlock pin in the bearing housing as in step 4.

7. Install the shift fork and rod (1st/2nd), the springs balls, and the caps.

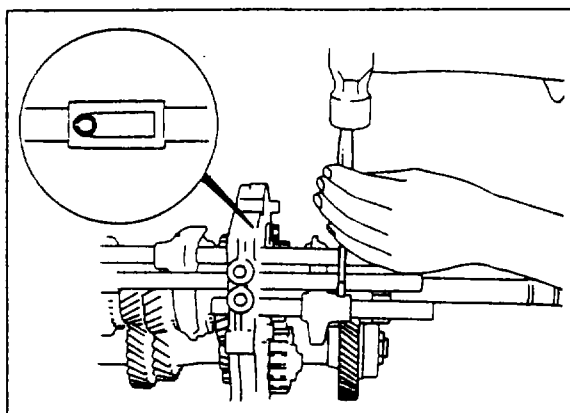

67U07A-062

8. Install the spring pins in the shift forks.

Caution

The spring pin should be installed so the groove of the pin is as shown in the figure.

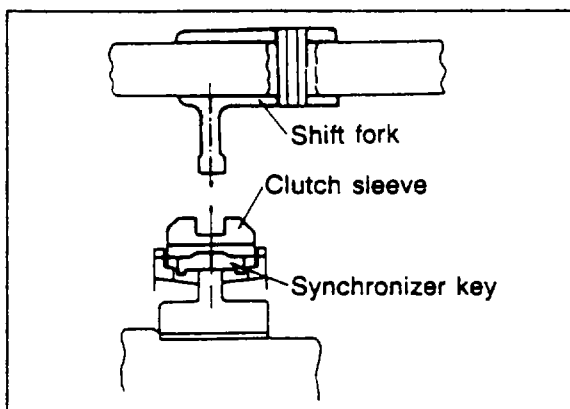

67U07A-062

Adjustment of Shift Fork and Clutch Hub Sleeve

1. To obtain the correct position of the shift fork to the clutch hub sleeve, select the proper thrust washer for between 1st gear and the mainshaft bearing, or reverse gear and the mainshaft bearing.

7A ASSEMBLY

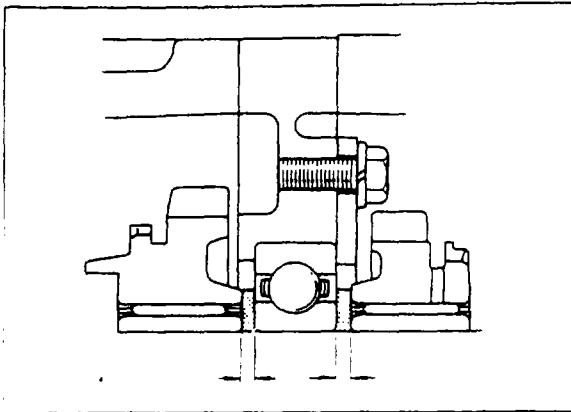

67U07A-063

2. The following thrust washer thicknesses are available for use.

2.2 mm (0.0866 in)	3.2 mm (0.1260 in)
2.7 mm (0.1063 in)	3.7 mm (0.1457 in)
3.0 mm (0.1181 in)	

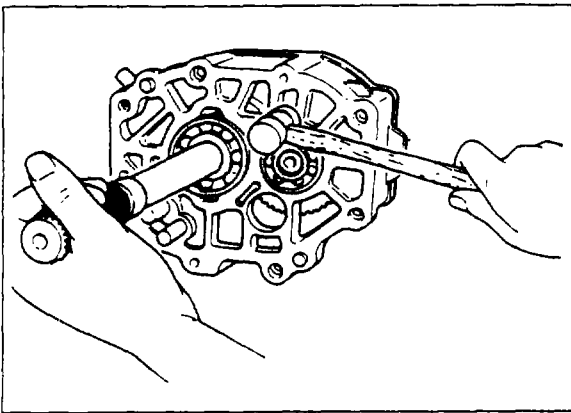

67U07A-064

Intermediate Housing

1. Coat the intermediate housing mounting surfaces with sealant.
2. Mount the intermediate housing to the bearing housing by tapping lightly with plastic hammer.

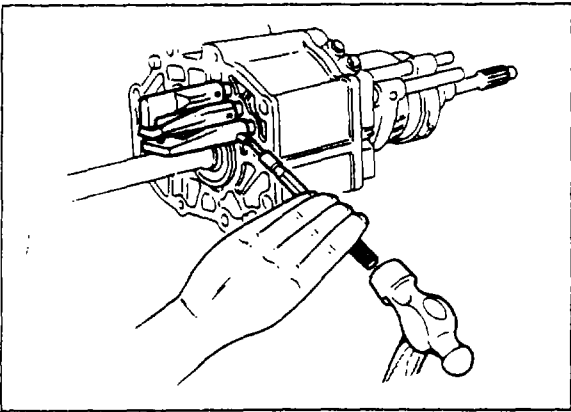

67U07A-065

Rod End

Install the shift rod ends on the shift rods.

Speedometer Drive Gear

1. Install the snap ring.
2. Mount the ball and speedometer drive gear, and secure them with a snap ring.

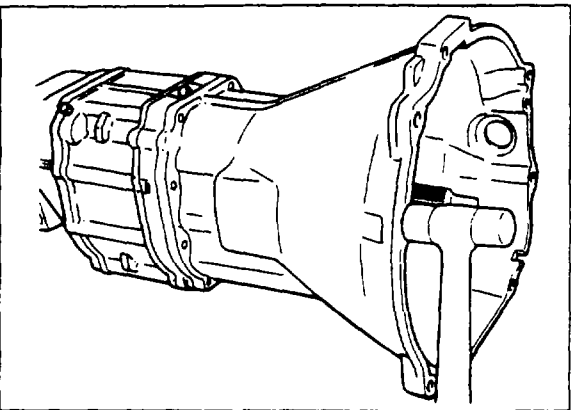

67U07A-066

Transmission Case

1. Coat the mounting surfaces of the transmission case and bearing housing with sealant.
2. Mount the transmission case to the bearing housing by tapping lightly with a plastic hammer.

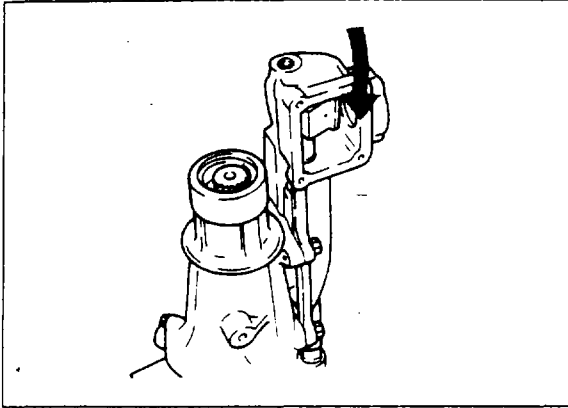

67U07A-067

Extension Housing

1. Coat the mounting surfaces of the extension housing and intermediate housing with sealant.
2. Shift the clutch hub sleeves to 1st gear.
3. Turn the control rod in the direction of the arrow and install the extension housing.
4. Tighten the bolts.

Tightening torque:

16—23 N·m (1.6—2.3 m·kg, 12—17 ft·lb)

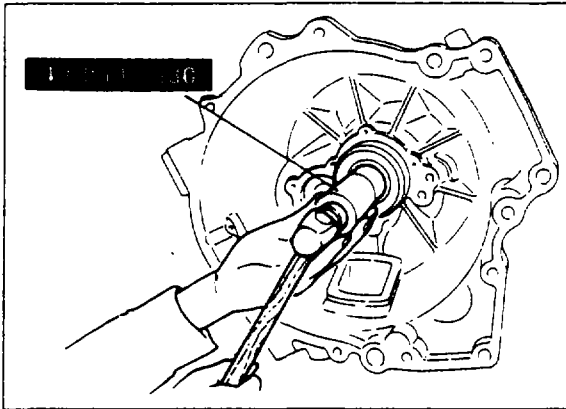

67U07A-068

Bearing

1. Drive the main drive shaft bearing on using **bearing installer** (49 0500 330) and secure with the two snap rings.

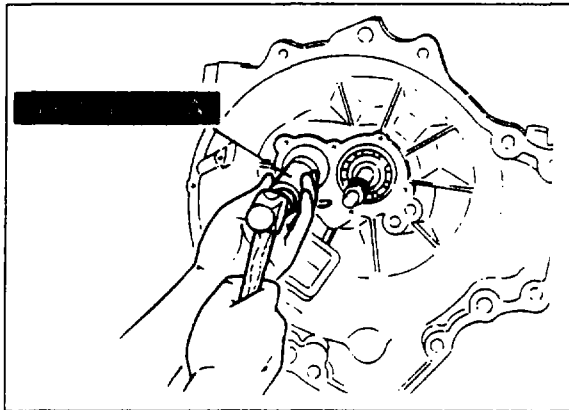

67U07A-069

2. Drive the counter shaft bearing on using **bearing installer** (49 0180 321A).

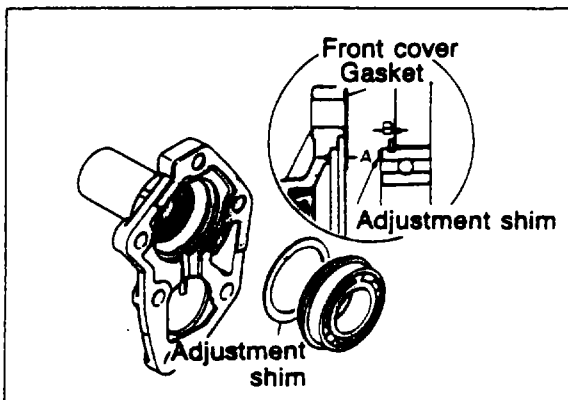

67U07A-070

Front Cover

1. After measuring dimensions (A) and (B), use an adjust shim(s), of a thickness corresponding to the value of (A) minus (B), so that bearing end play will be within the specification.

Bearing end play:

0—0.1 mm (0—0.004 in)

Adjust shim thickness:

0.15 mm (0.006 in)

0.30 mm (0.012 in)

7A ASSEMBLY, INSTALLATION

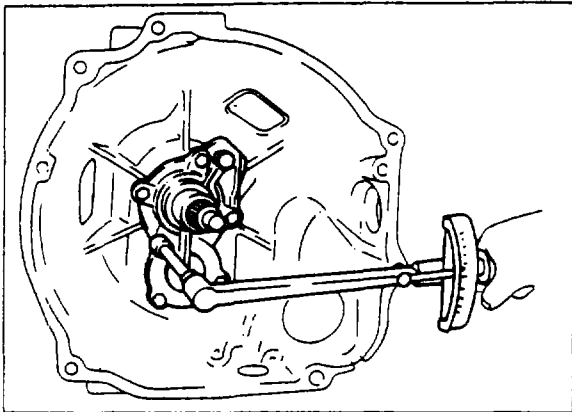

67U07A-071

2. Install the front cover.

Tightening torque:

19—26 N·m (1.9—2.6 m·kg, 14—19 ft·lb)

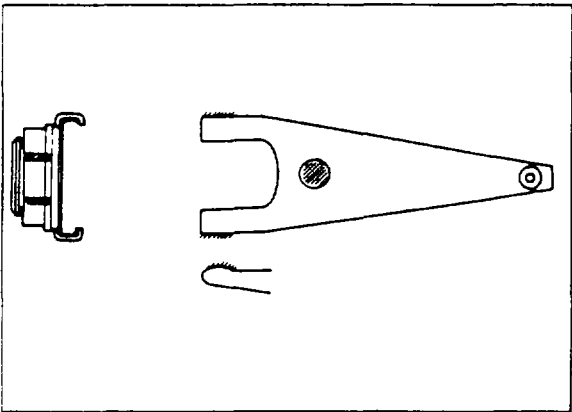

67U07A-072

Release Fork

1. Apply molybdenum disulphide grease to the parts of the release bearing and release fork indicated by the shaded lines in the figure.
2. Install the release bearing and release fork.

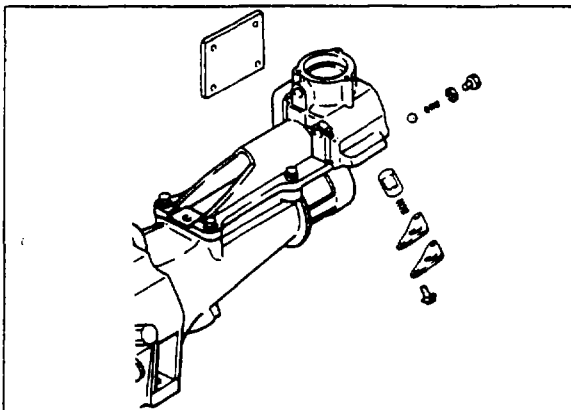

77U07A-129

Select Lock Spindle

1. Install the select lock spindle, spring and spring cap.
2. Push the select lock spindle down by pushing on the control rod.
Insert the ball and spring, and install the spring cap.

INSTALLATION

Install the transmission in the reverse order of removal.

Note

Fill the transmission with the correct grade and quantity of lubricant.

67U07A-074

DISASSEMBLY.....TURBO MODEL

Disassemble in the sequence shown in the figure.
CLUTCH HOUSING AND EXTENSION HOUSING

77U07A 11B

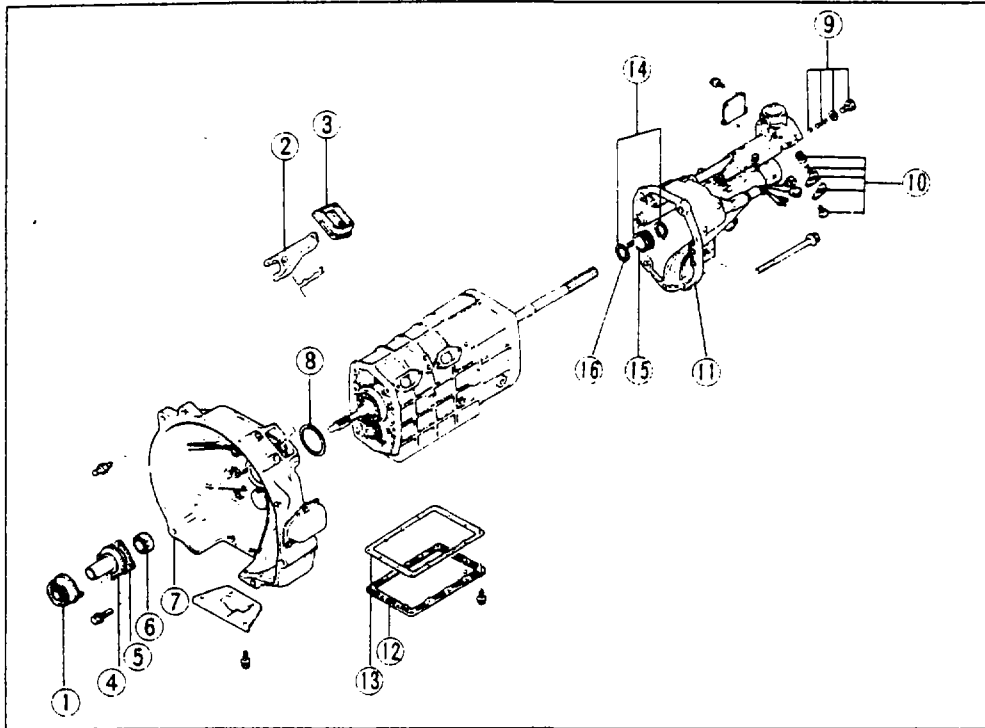

1. Release bearing
2. Release fork
3. Boot
4. Front cover
5. Gasket
6. Oil seal
7. Clutch housing
8. Adjust shim(s)
9. Bolt, spring and lock ball
10. Cover and select lock spindle
11. Extension housing
12. Under cover
13. Gasket
14. Snap ring(s)
15. Speedometer drive gear
16. Key

77U07A 006

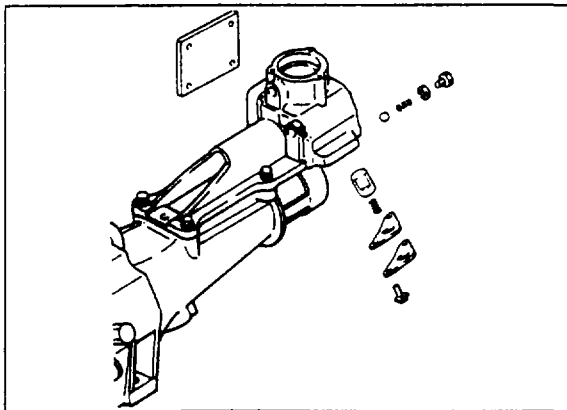

67U07A-009

Extension Housing

1. Remove the cap bolt, spring and lock ball.
2. Remove the cover, spring and select lock spindle.
3. Remove the control case cover.

4. Remove the extension housing attaching bolts.

Note

Do not remove the change control case.

5. Turn the control rod in the direction of the arrow and remove the extension housing.

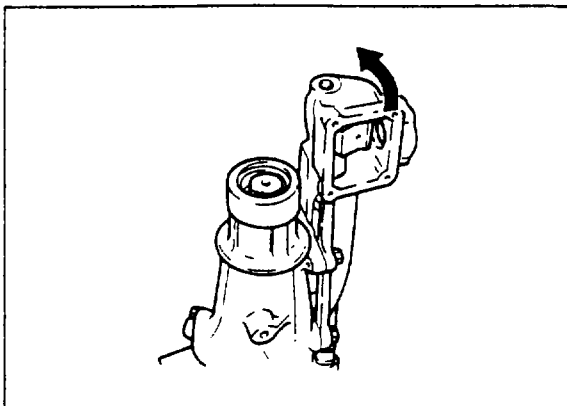

77U07A-007

7A DISASSEMBLY

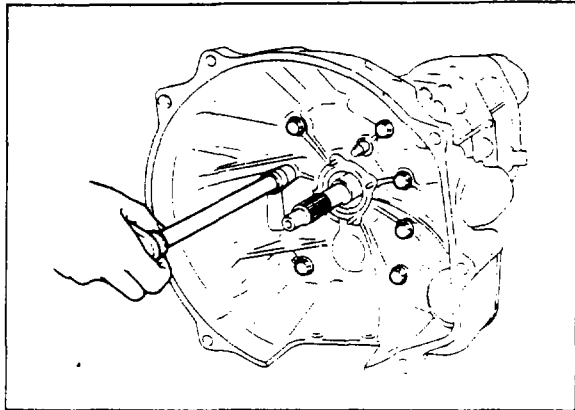

77U07A-008

Clutch Housing

Remove the clutch housing.

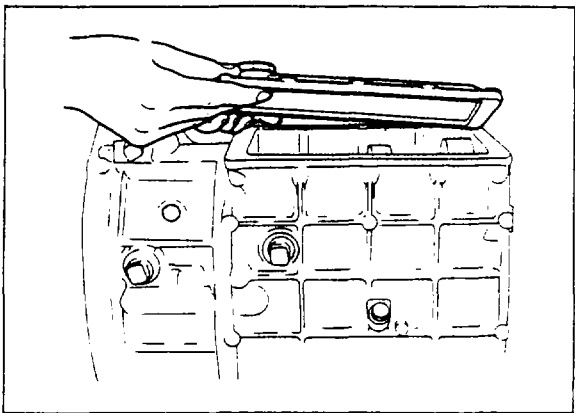

77U07A-009

Under Cover

Remove the under cover.

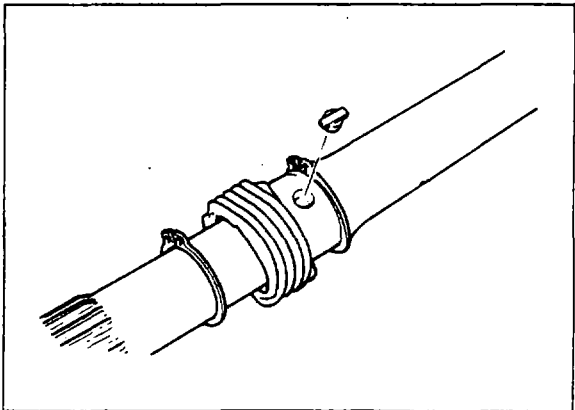

77U07A-010

Speedometer Drive Gear

Remove the snap ring, speedometer drive gear, key and snap ring.

HOUSING PARTS

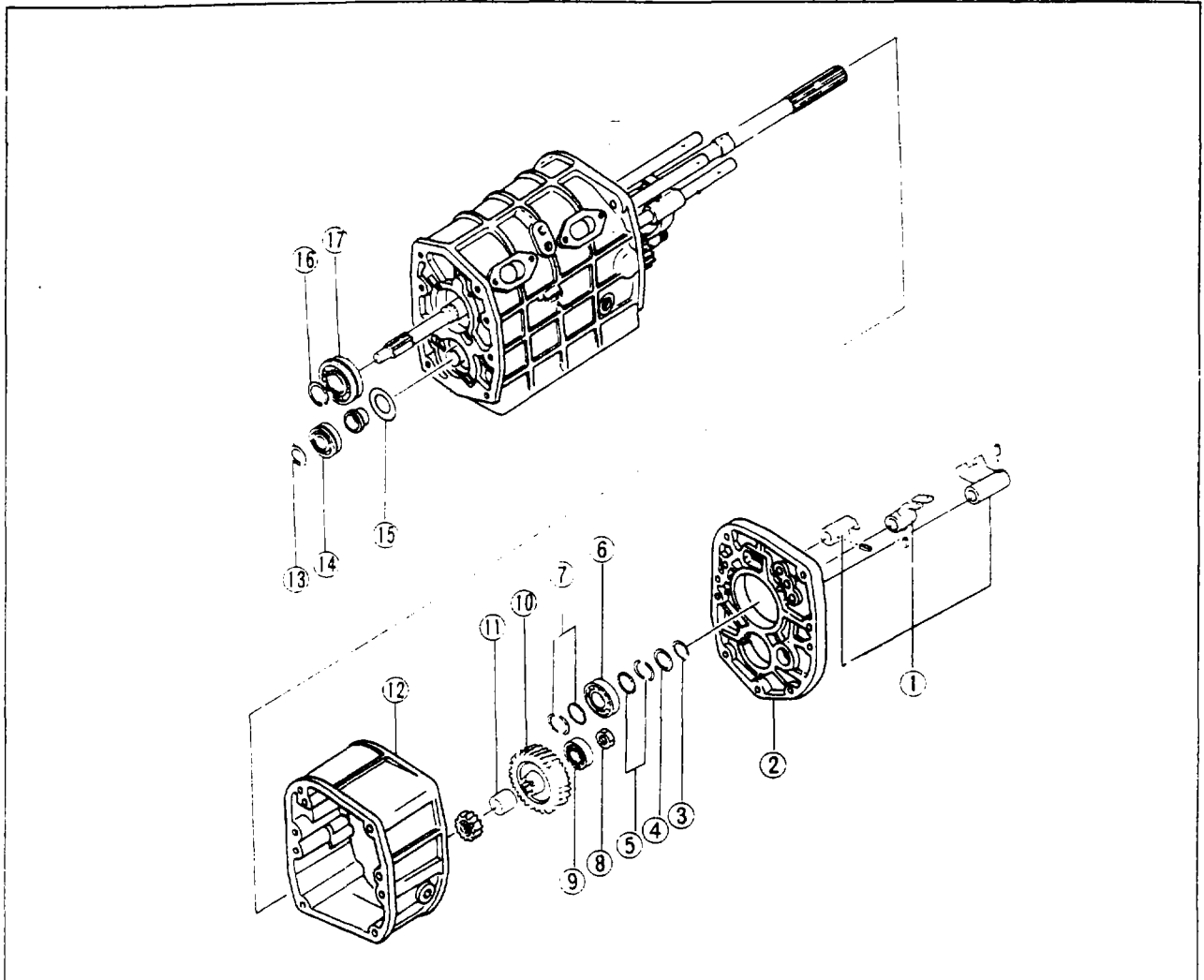

77U07A-011

- | | | |
|-----------------------------------|-----------------------------------|--------------------------------|
| 1. Shift rod end(s) | 6. Mainshaft rear bearing | 11. Spacer |
| 2. Bearing housing | 7. "C" washers and retaining ring | 12. Center housing |
| 3. Snap ring | 8. Lock nut | 13. Snap ring |
| 4. Adjust washer | 9. Countershaft rear bearing | 14. Countershaft front bearing |
| 5. "C" washers and retaining ring | 10. Counter gear | 15. Adjust shim(s) |
| | | 16. Snap ring |
| | | 17. Main drive gear bearing |

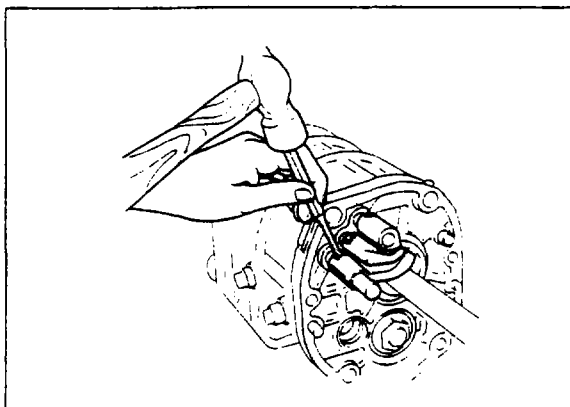

77U07A-012

Shift Rod Ends

Remove the spring pins and shift rod ends.

7A TRANSMISSION

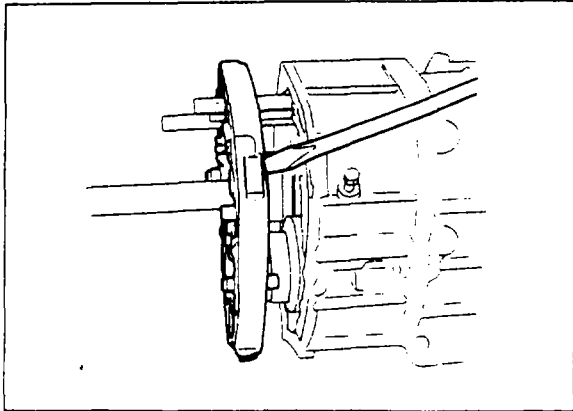

77U07A-013

Bearing Housing

Gently pry the bearing housing away from the transmission case with a flattipped screwdriver, being careful not to damage the housing or case. Slide the bearing housing off the mainshaft.

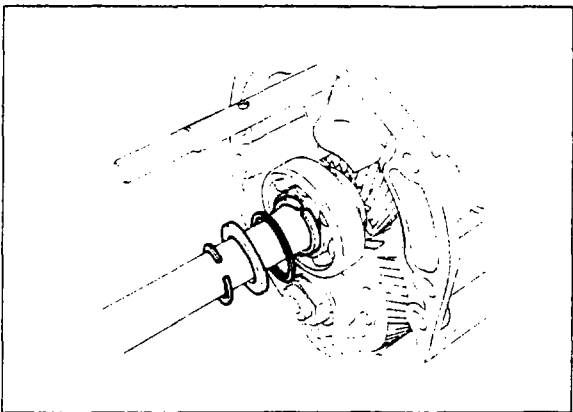

77U07A-014

Mainshaft Rear Bearing

1. Remove the snap ring, washer, retaining ring, and C washers.

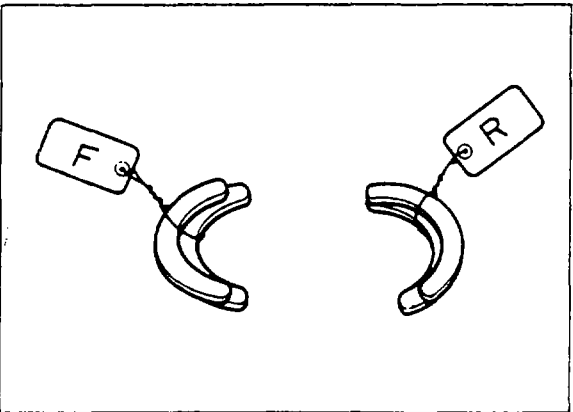

7BU07A-016

2. For proper reassembly, identify the front and rear C washers.

Note

The front and rear C washers may have different thicknesses.

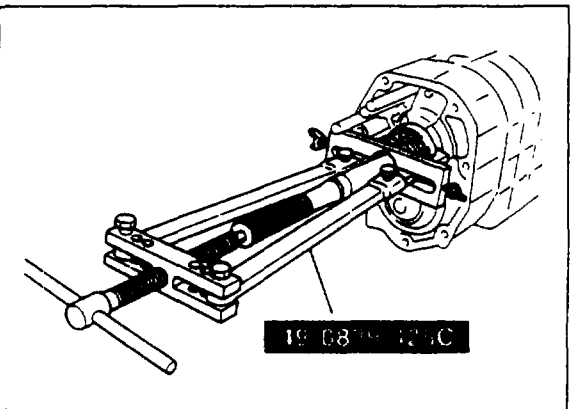

78U07A-017

3. Remove the mainshaft rear bearing with the **bearing puller set** (49 0839 425C).

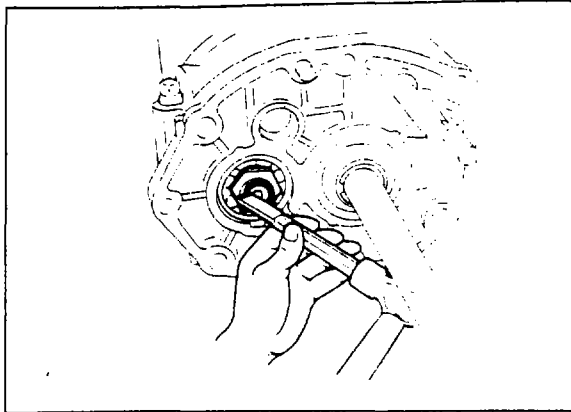

77U07A-016

Countershaft Rear Bearing

1. Uncrimp the tab of the lock nut.

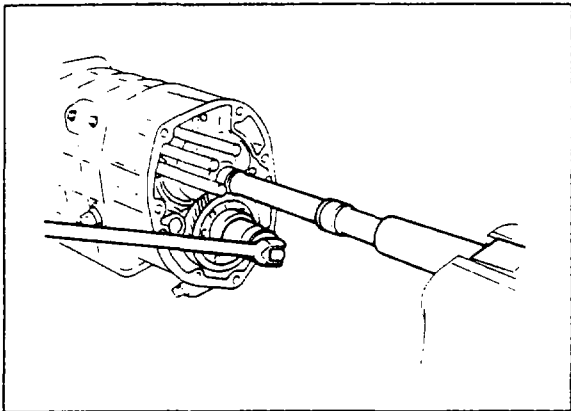

77U07A-017

2. Shift the clutch hub sleeves to first gear and reverse gear to put the gears in the double-engaged condition.
3. Remove the lock nut.

Caution
Do not re-use the lock nut.

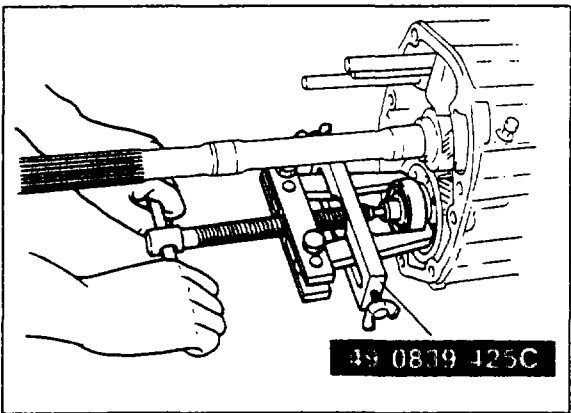

77U07A-018

4. Remove the countershaft rear bearing using **bearing puller set** (49 0839 425C).

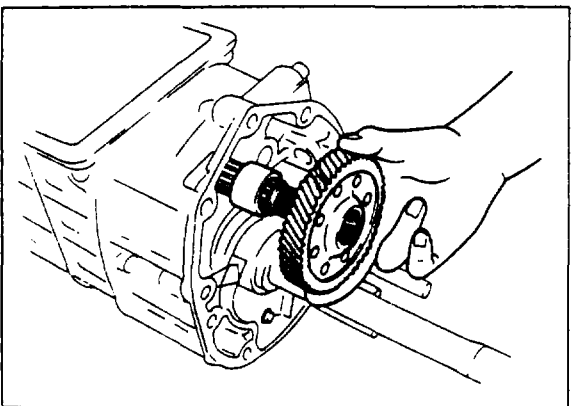

77U07A-019

Counter 5th Gear

Remove the counter 5th gear and spacer from the rear of the countershaft.

7A DISASSEMBLY

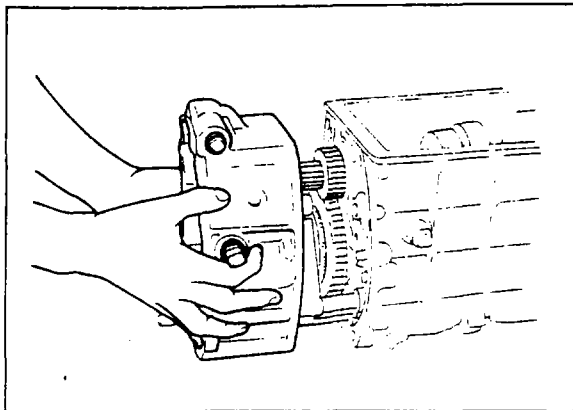

77U07A-020

Center Housing

1. Remove the cap screw from center housing.
2. Tap the housing with a plastic hammer, if necessary, and remove the center housing.

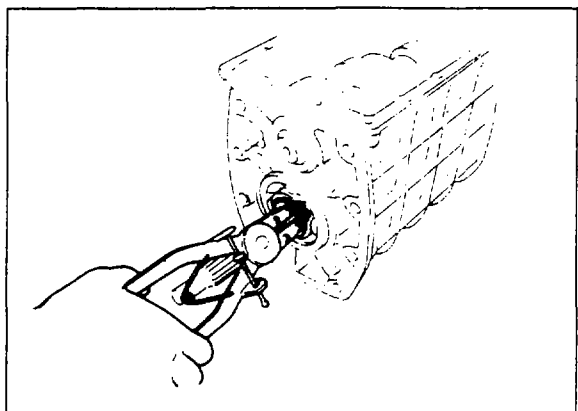

77U07A-021

Main Drive Gear Front Bearing

1. Remove the snap ring from the main drive gear.

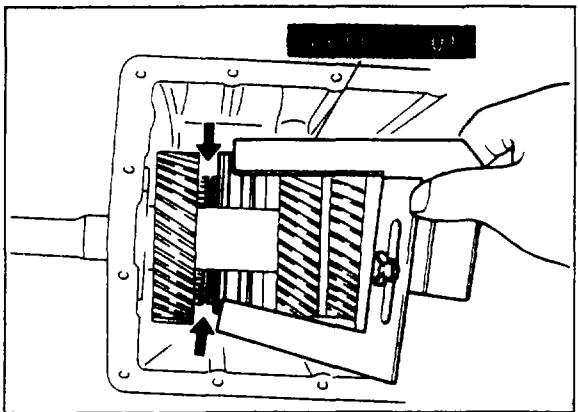

77U07A-119

2. Install the **synchronizer ring holder** (49 F017 101) between the 4th speed synchronizer ring and synchronesh gear on the mainshaft.

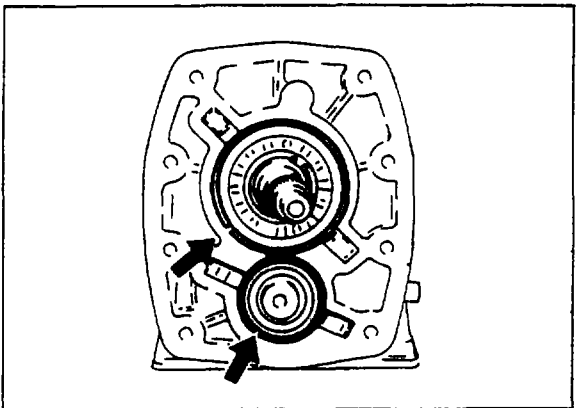

77U07A-023

3. Remove the main drive gear bearing using **bearing puller set** (49 0839 425C).

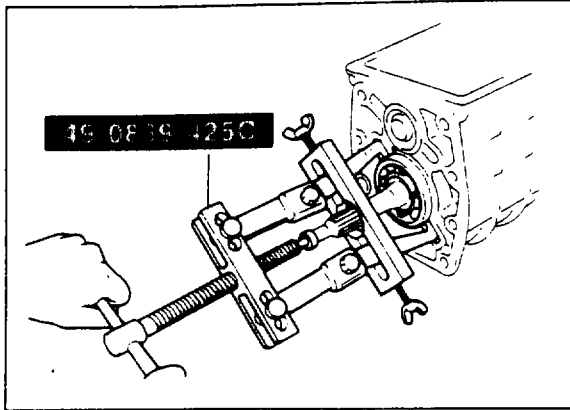

7BU07A-022

4. remove the mainshaft front bearing with the **bearing puller set** (49 0839 425C).

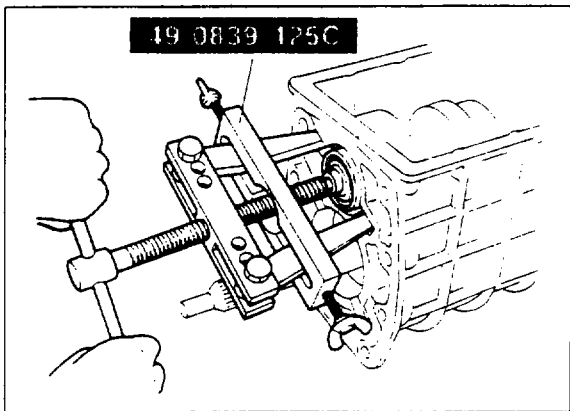

77U07A-024

Countershaft Front Bearing

1. Remove the snap ring from the front of the countershaft.
2. Remove the countershaft front bearing using **bearing puller set** (49 0839 425C).

7A DISASSEMBLY

5TH/REVERSE GEAR

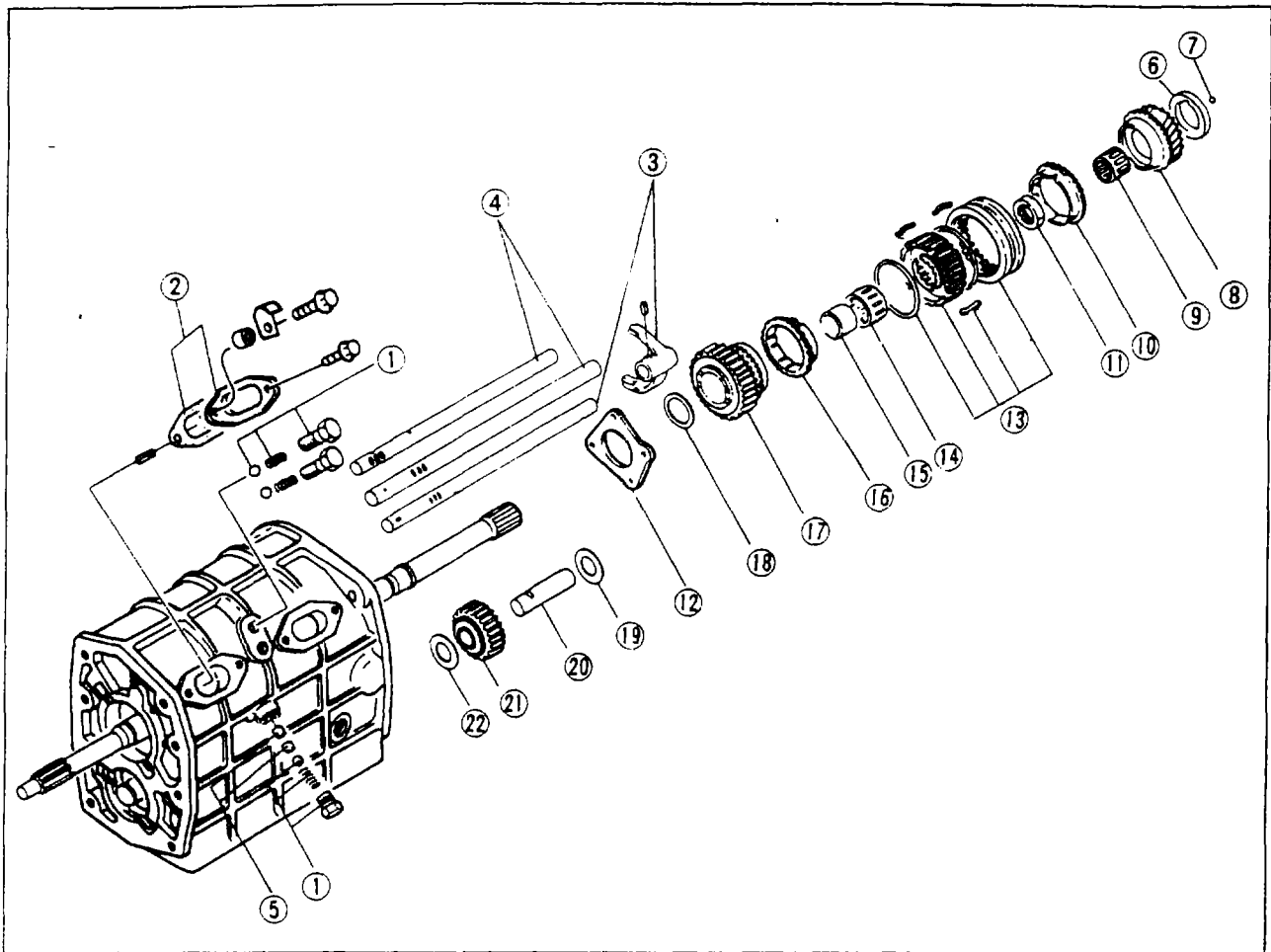

78U07A-023

- | | | |
|-------------------------------------|---------------------------------------|-----------------------------|
| 1. Bolt, spring, and ball | 8. 5th gear | 15. Inner case |
| 2. Blind cover | 9. Needle bearing | 16. Synchronizer ring |
| 3. Shift fork (5th/reverse) and rod | 10. Synchronizer ring | 17. Reverse gear |
| 4. Shift rods | 11. Locknut | 18. Thrust washer |
| 5. Interlock pin | 12. Bearing stopper | 19. Thrust washer |
| 6. Thrust lock washer | 13. Clutch hub assembly (5th/reverse) | 20. Reverse idle gear shaft |
| 7. Lock ball | 14. Needle bearing | 21. Reverse idle gear |
| | | 22. Thrust washer |

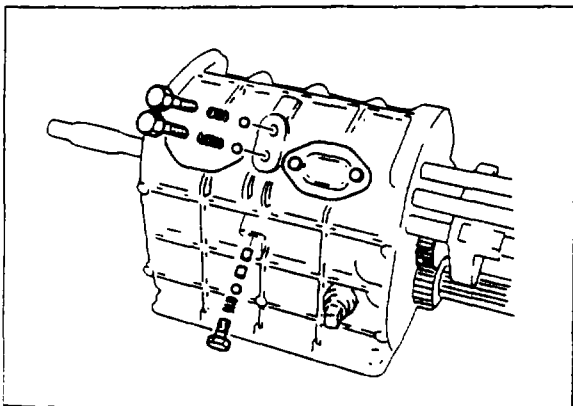

77U07A-026

Shift Rod

1. Remove the three spring cap bolts, and then remove the balls and springs.

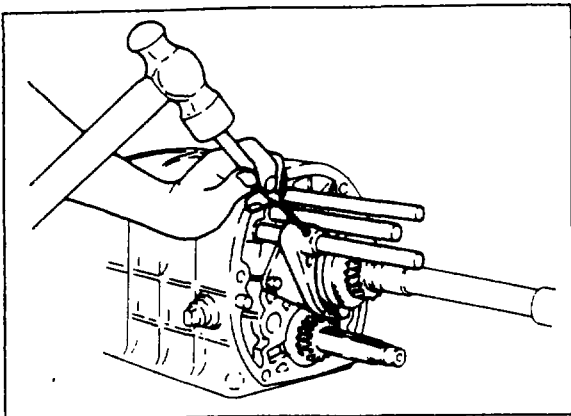

77U07A-027

2. Drive the spring pin from the 5th/reverse shift fork. Slide the 5th/reverse shift rod out of the transmission case.

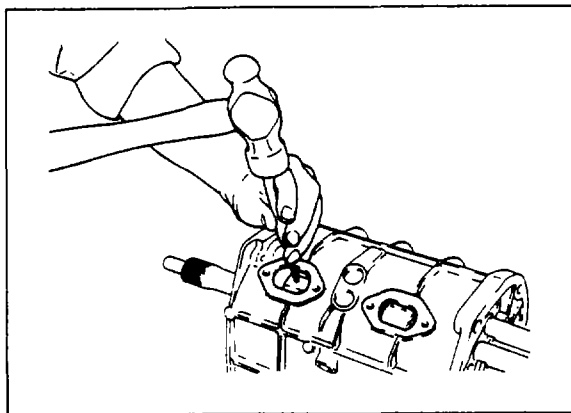

77U07A-028

3. Remove the covers and gaskets.
4. Shift the transmission into 4th gear. This will provide adequate space to drive out the spring pin. Drive the spring pin from 3rd/4th shift fork.
5. Slide the 3rd/4th shift rod out of the rear of the transmission case.

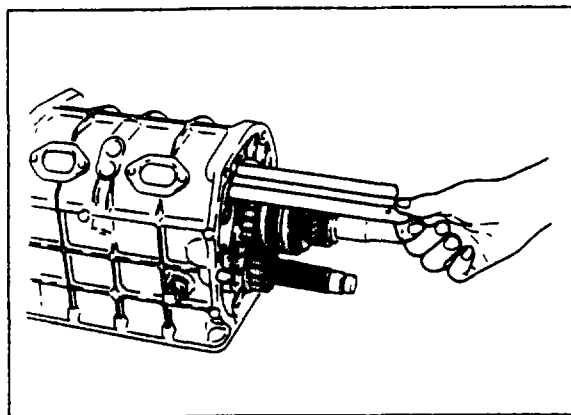

77U07A-029

6. Drive the spring pin from the 1st/2nd shift fork. Slide the 1st/2nd shift rod out the rear of the transmission case.
7. Remove both interlock pins.

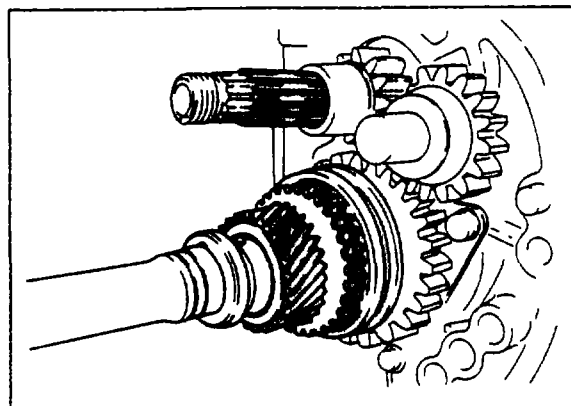

78U07A-026

5th Gear

Remove the thrust washer, lock ball, needle bearing, 5th gear, and synchronizer ring from the rear of the mainshaft.

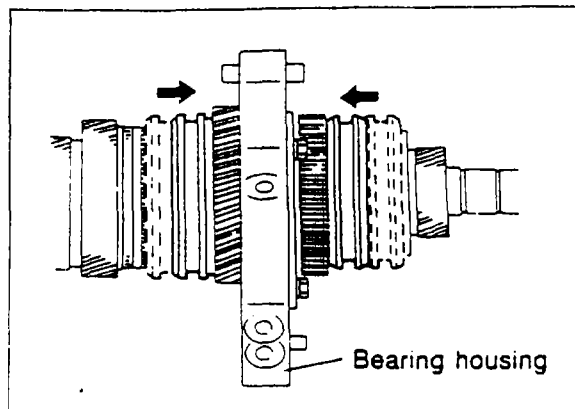

77U07A-031

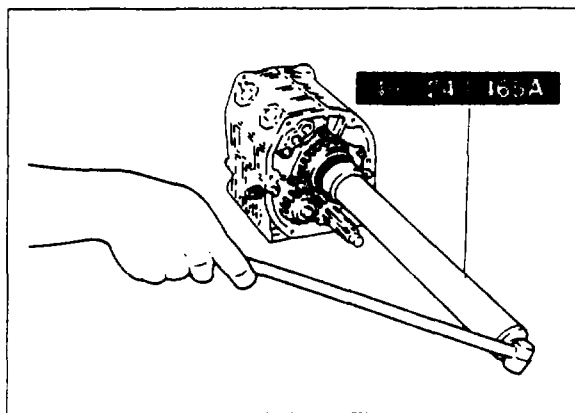

77U07A-032

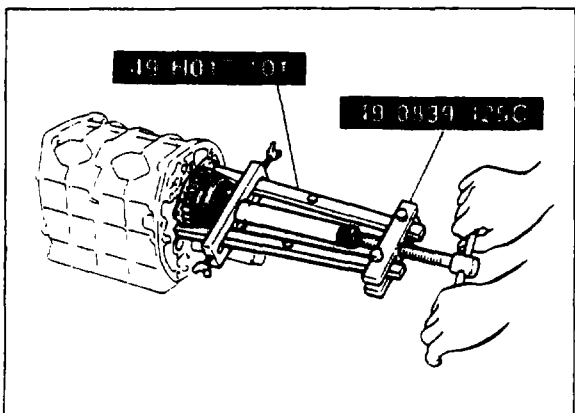

7BU07A-027

5th/Reverse Clutch Hub Assembly

1. Uncrimp the tabs of the locknut.
2. Shift into 1st gear and reverse gear to lock the rotation of the mainshaft.

3. Remove the locknut using the **locknut wrench** (49 1243 465A).

Caution

Do not reuse the locknut.

4. Remove the bearing stopper installation bolts.
5. Attach the **bearing puller set** (49 0839 425C) and **hook** (49 H017 101) to the bearing stopper, and remove the assembly containing the following parts:
 - 5th/reverse clutch hub assembly
 - Synchronizer ring
 - Needle bearing
 - Inner race
 - Reverse gear
 - Thrust washer
6. Remove the thrust washers, reverse idle gear shaft, and reverse idle gear.

MAINSHAFT

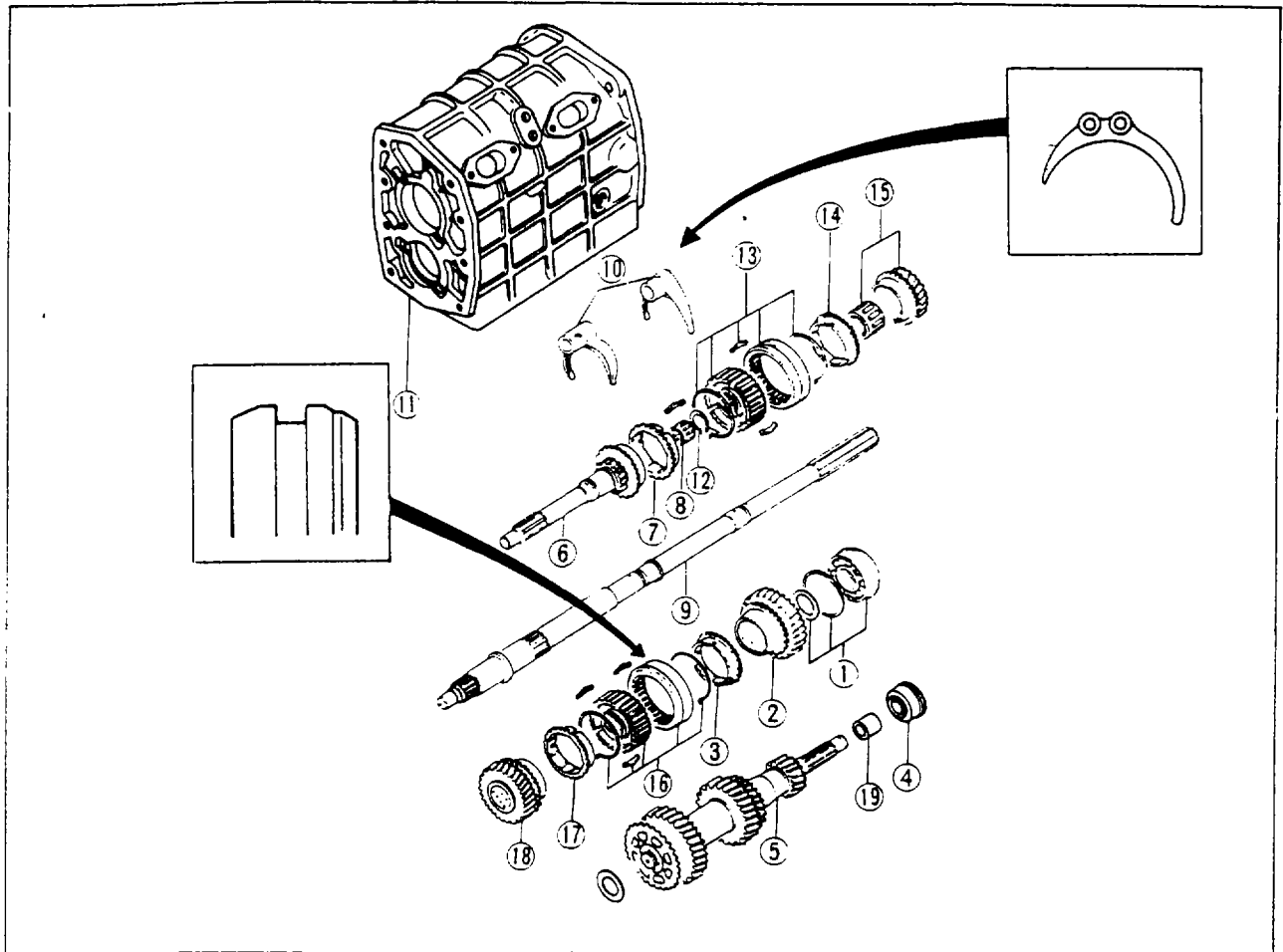

69G07A-088

- | | | |
|--|-----------------------------------|-----------------------------------|
| 1. Mainshaft bearing, adjust shim, and thrust washer | 8. Needle bearing | 15. 3rd gear and needle bearing |
| 2. 1st gear | 9. Mainshaft | 16. Clutch hub assembly (1st/2nd) |
| 3. Synchronizer ring (1st) | 10. Shift forks | 17. Synchronizer ring (2nd) |
| 4. Countershaft rear bearing | 11. Transmission case | 18. 2nd gear |
| 5. Countershaft | 12. Snap ring | 19. Inner race |
| 6. Main drive gear | 13. Clutch hub assembly (3rd/4th) | |
| 7. Synchronizer ring (4th) | 14. Synchronizer ring (3rd) | |

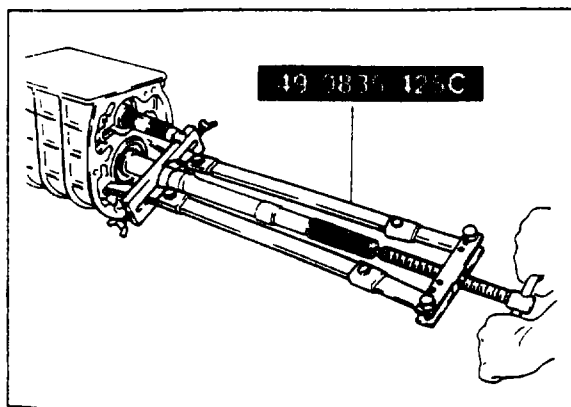

87U07A-007

Disassembly Note Mainshaft bearing

1. Remove the mainshaft bearing using **bearing puller set (49 0839 425C)**.
2. Remove the 1st gear.

7A DISASSEMBLY

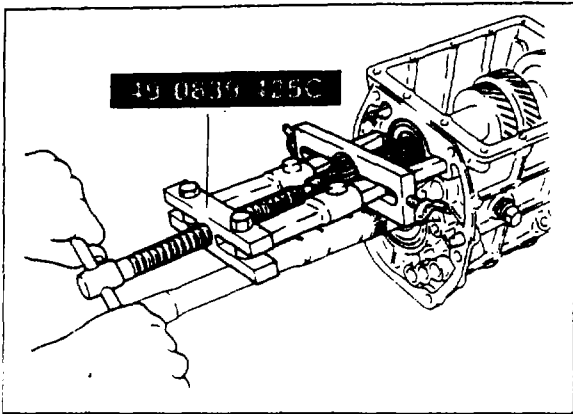

77U07A-036

Countershaft

1. Remove the countershaft center bearing using bearing puller set (49 0839 425C).

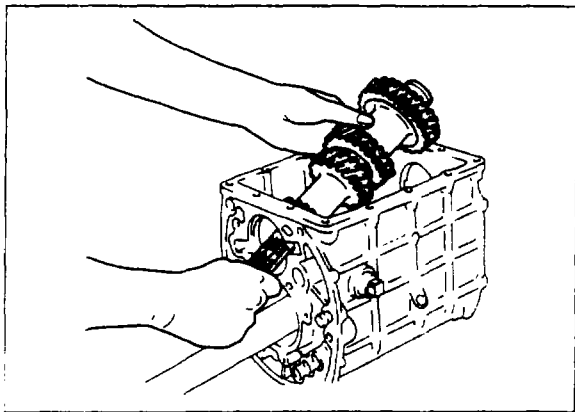

77U07A-037

2. Remove the countershaft.

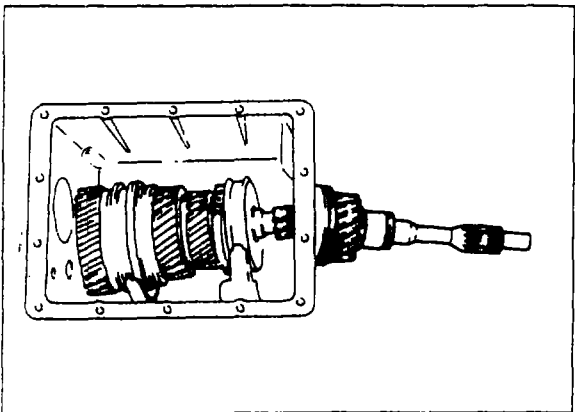

77U07A-038

Mainshaft

1. Remove the main drive gear from the transmission case.

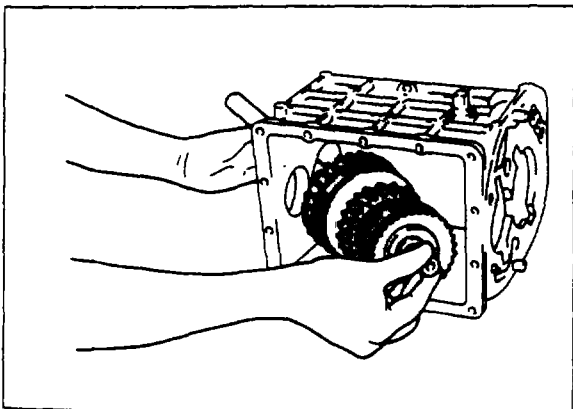

77U07A-039

2. Remove the mainshaft and gear assembly from the transmission case.

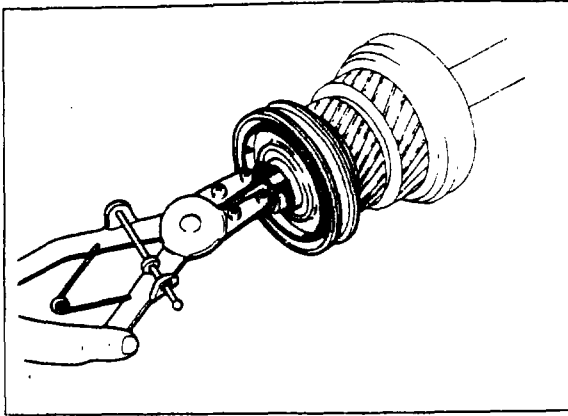

77U07A-04C

Clutch Hub

1. Remove the snap ring from the front of the mainshaft.

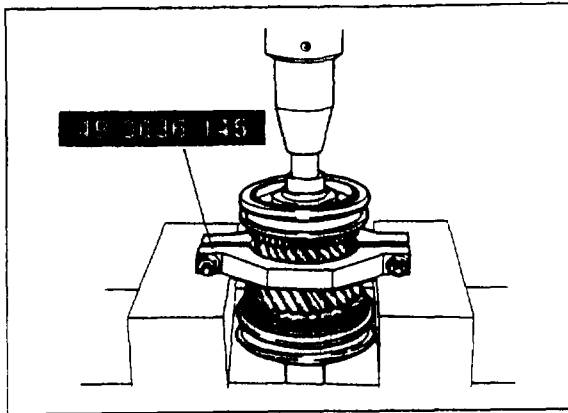

77U07A-041

2. Position the **puller** (49 0636 145) between 2nd and 3rd gear.

3. Press the mainshaft out of 3rd gear and 3rd/4th clutch hub assembly.

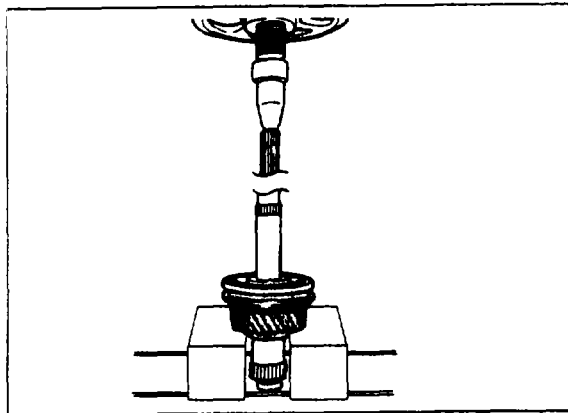

77U07A-042

4. Press the 1st/2nd clutch hub assembly and 1st gear sleeve from the mainshaft.

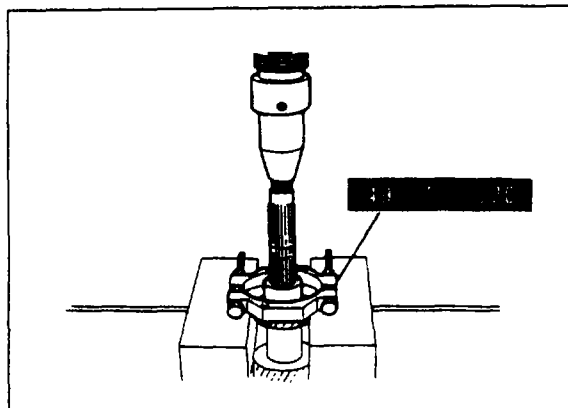

77U07A-043

Bearing Inner Race

Remove the inner race of the countershaft bearing from countershaft using **puller** (49 0710 520).

7A INSPECTION

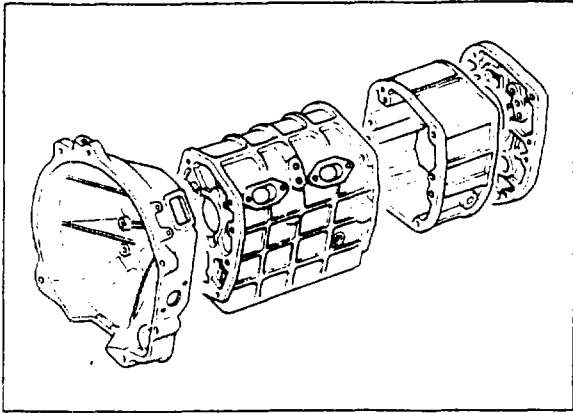

77U07A-044

INSPECTION

Check each of the items listed below, repair or replace if necessary.

Transmission Case and Housing

1. Cracks, damage or wear.
2. Rough contact surfaces or damage.

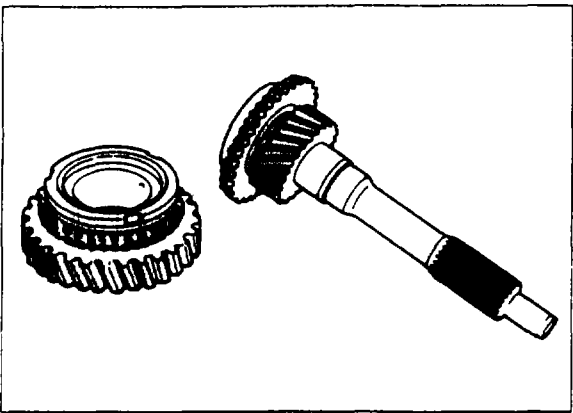

67U07A-026

Each Gear and Main Drive Gear

1. Worn or damaged synchronizer cones.
2. Worn or damaged hub sleeve parts.
3. Worn or damaged teeth.
4. Worn or damaged inner gear or outer gear surfaces.
5. Worn or damaged main drive shaft splines.

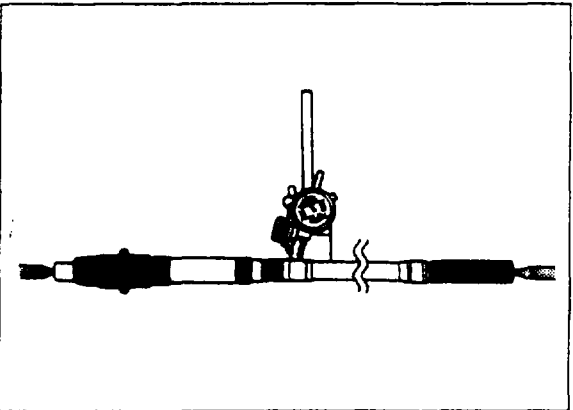

77U07A-121

Mainshaft

1. Runout.

Max: 0.20 mm (0.0079 in)

2. Worn or damaged splines.

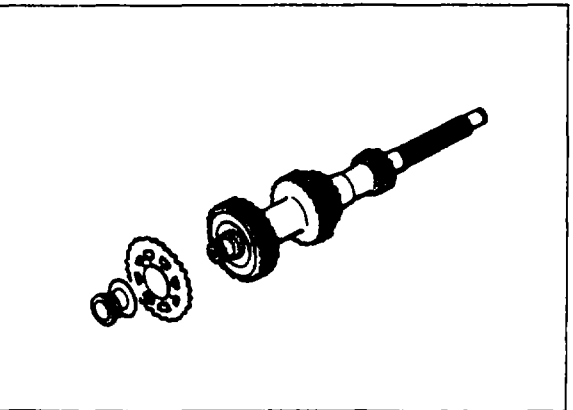

67U07A-028

Countershaft

1. Worn or damaged gear teeth.
2. Worn or damaged splines.
3. Worn or damaged friction gears.

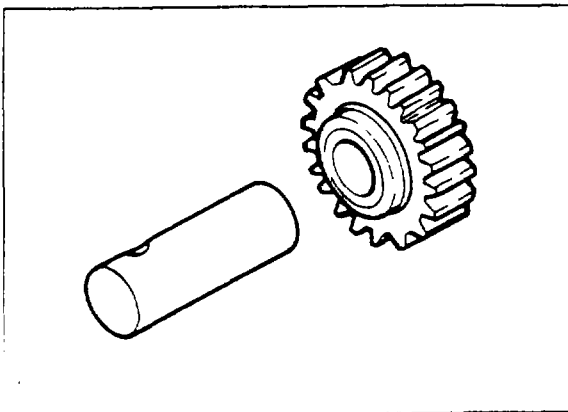

67U07A-029

Reverse Idle Gear and Shaft

1. Worn or damaged gear.
2. Worn shaft.

Standard clearance:

0.02—0.05 mm (0.0008—0.0020 in)

Max: 0.15 mm (0.0059 in)

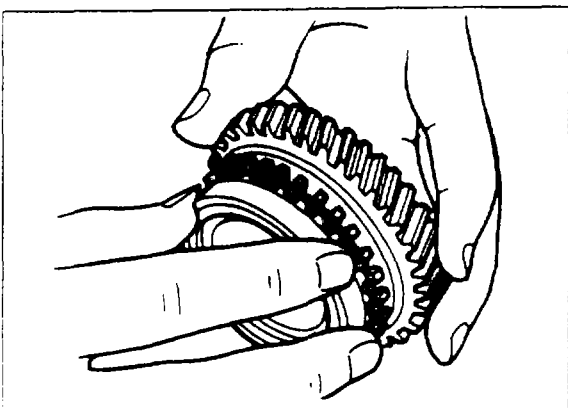

67U07A-030

Synchronizer Ring

1. Gear cone mesh.
2. Worn or damaged splines.
3. Worn or damaged taper surface.

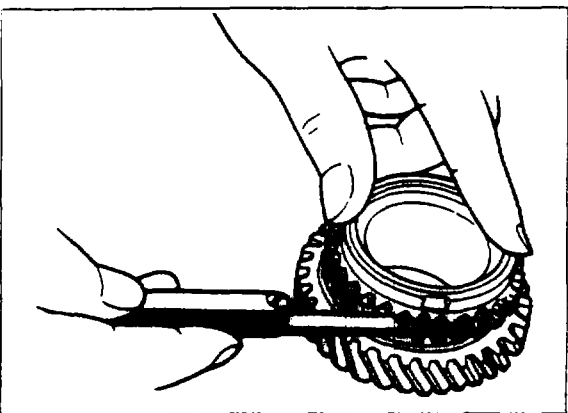

77U07A-122

4. Clearance between synchronizer ring and flank surface of gear.

Standard clearance: 1.5 mm (0.059 in)

Max: 0.8 mm (0.031 in)

Note

Set the synchronizer ring straight in the gear, and measure around the circumference.

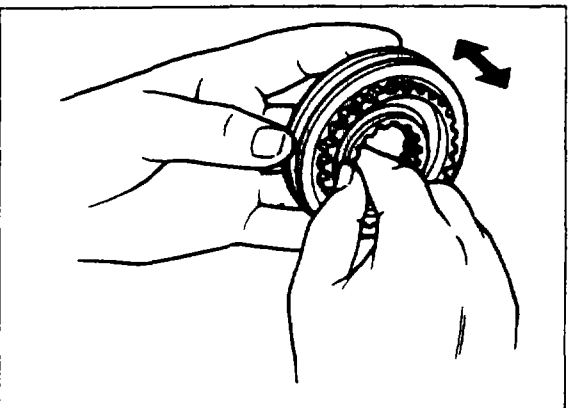

67U07A-032

Clutch Hub

1. Operation of clutch hub sleeve and hub.
2. Worn or damaged hub sleeve sliding surface.
3. Worn or damaged hub synchronizer key groove.
4. Worn gear teeth.

7A INSPECTION

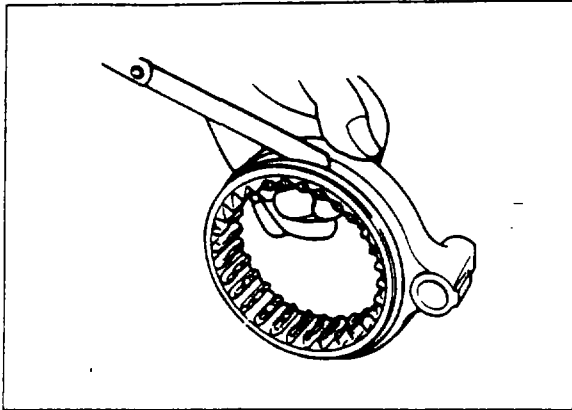

77U07A-046

Clutch Hub Sleeve

1. Worn or damaged clutch hub sliding surfaces.
2. Clearance between hub sleeve and release fork.

Standard clearance:

0.2—0.3 mm (0.008—0.012 in)

Max: 0.5 mm (0.020 in)

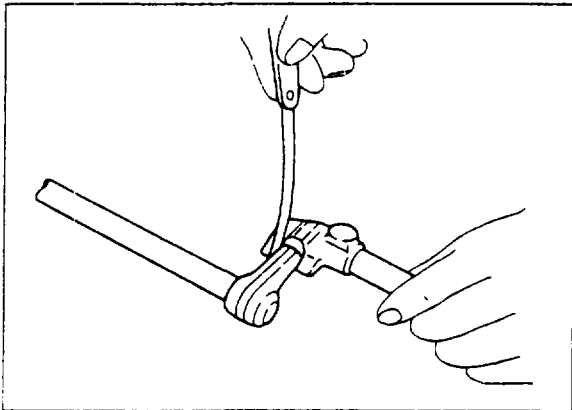

67U07A-034

Control Lever and Shift Rod

1. Clearance between the control lever and the gate of the shift rod.

Clearance: 0.8 mm (0.0315 in) max.

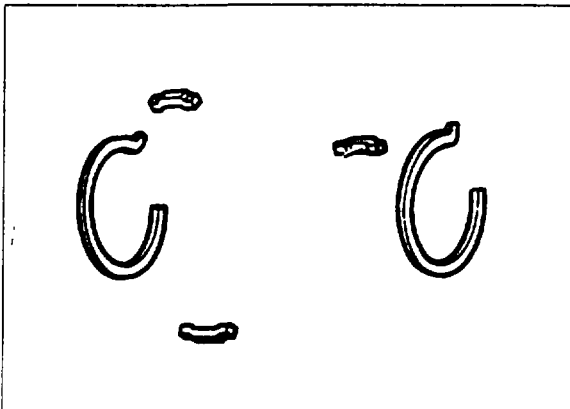

67U07A-035

Synchronizer Key and Key Spring

1. Worn key.
2. Fatigued or damaged spring.

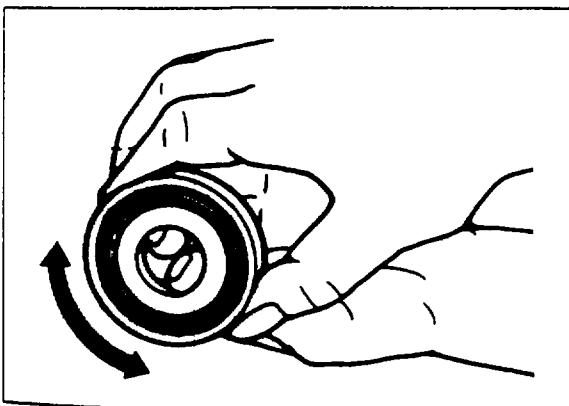

67U07A-036

Bearing

1. Roughness or noise while turning.
2. Damaged bearing.
3. Worn bearing.

ASSEMBLY

ASSEMBLY NOTE Clutch Hub

Note

a) The synchronizer rings all have the same basic shape; therefore, be careful to select the correct ones.

- The 5th and reverse synchronizer rings are the smallest.
- The 5th has notches in the teeth.
- The 4th and 3rd are the next size up and are exactly the same.
- The 2nd and 1st are the biggest and are exactly the same.

b) There are two types of synchronizer key. Standard dimensions are as follows.

	mm (in)		
	①	②	③
1st and 2nd	18 (0.7087)	5.45 (0.2146)	6 (0.2362)
3rd, 4th, 5th, and Rev.	17 (0.6693)	4.25 (0.1791)	5 (0.1969)

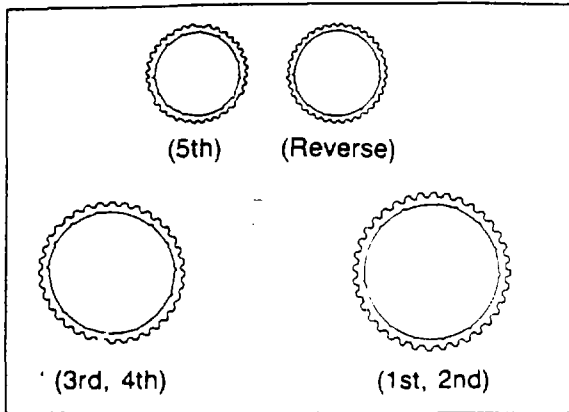

69G07A-102

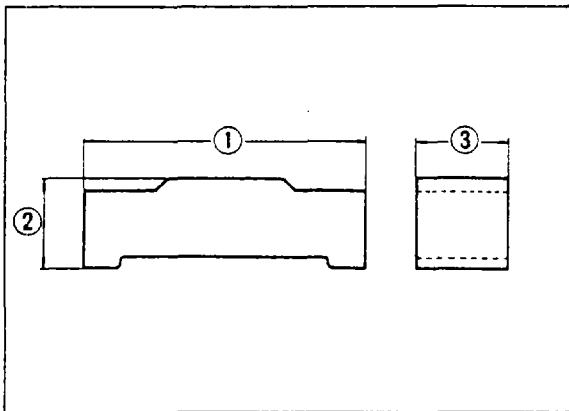

69G07A-103

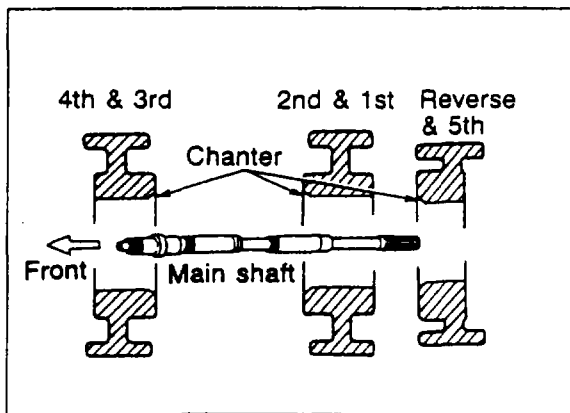

77U07A-130

- c) Press each clutch hub assembly onto the mainshaft in the proper direction.
d) Install the clutch hubs with the chamfer of the inner gear teeth as shown.

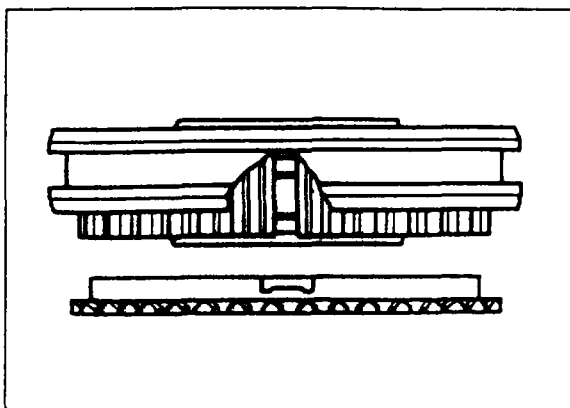

77U07A-050

Caution
Align the synchronizer ring groove and clutch hub key during installation.

7A ASSEMBLY

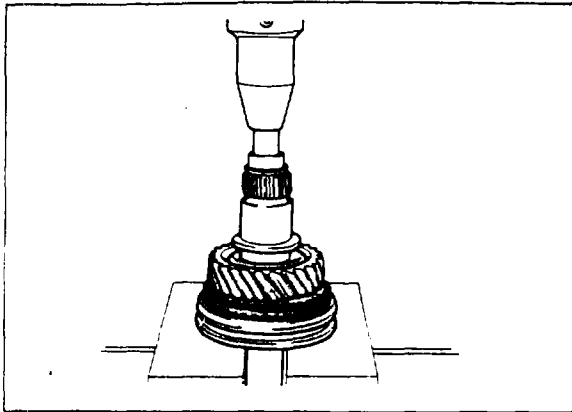

77U07A-051

1. Place the 2nd gear and 1st/2nd clutch hub assembly, and press in the mainshaft.

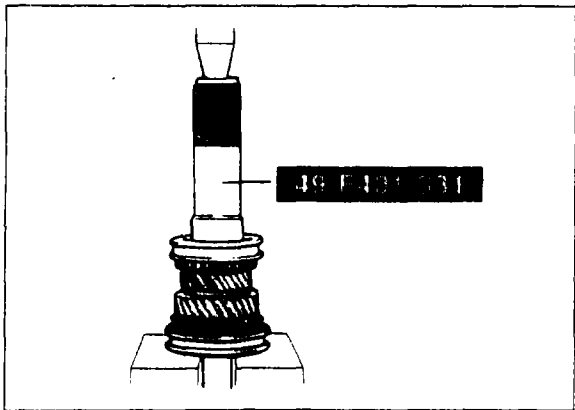

77U07A-052

2. Place the 3rd gear, needle bearing and 3rd/4th clutch hub assembly, press the 3rd/4th clutch hub assembly using **body** (49 F401 331).

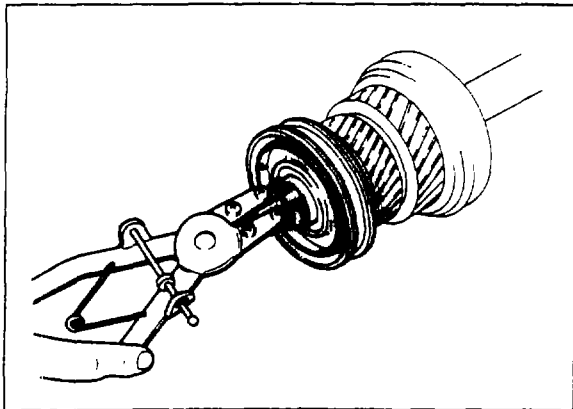

77U07A-053

3. Insert the snap ring to the front of the mainshaft using snap ring pliers.

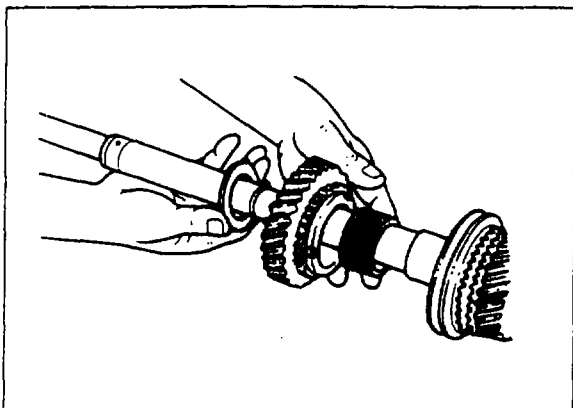

77U07A-054

4. Install the inner race, needle bearing, 1st gear and thrust washer.

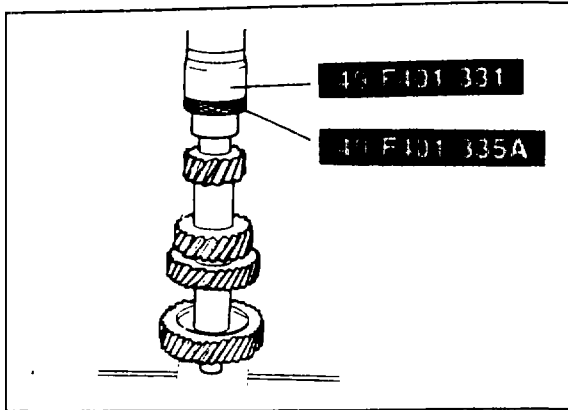

77U07A-055

Countershaft

Press the inner race of the countershaft rear bearing onto the countershaft, using the **body** (49 F401 331) and **attachment A** (49 F401 335A).

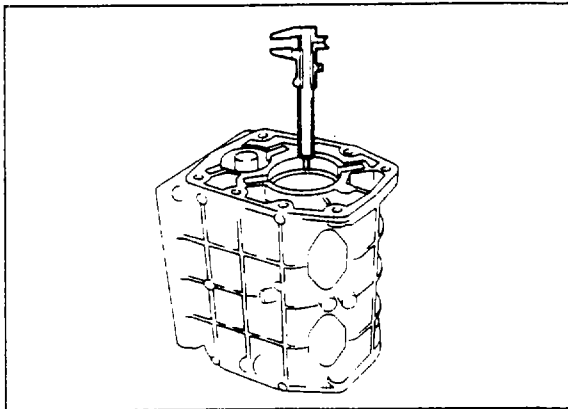

78U07A-036

Measurement of Bearing Thrust Play Mainshaft center bearing

1. Measure the depth of the main shaft center bearing bore in the transmission case.

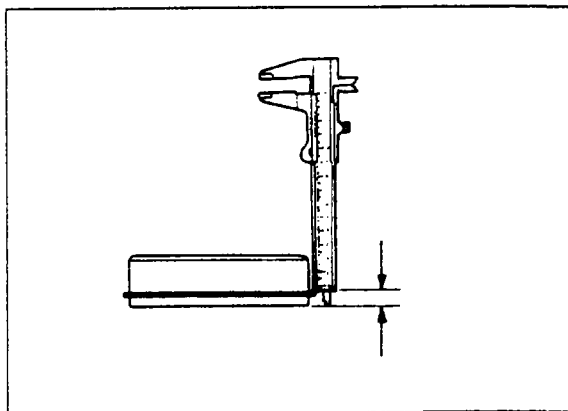

78U07A-037

2. Measure the mainshaft center bearing snap ring height. The difference between the two measurements indicates the required thickness of the adjusting shim.

Standard thrust play:

0—0.1 mm (0—0.004 in)

Adjusting shim thickness:

0.1 mm (0.004 in), 0.3 mm (0.012 in)

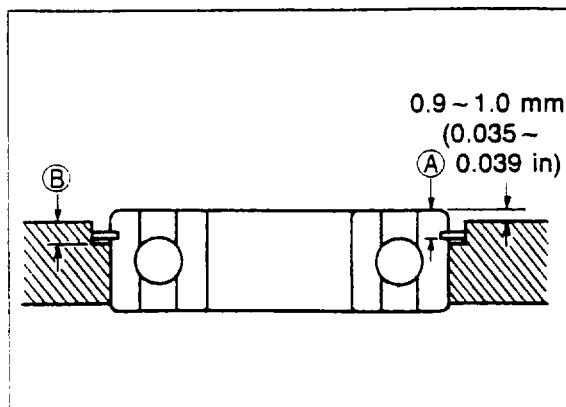

69G07A-112

Countershaft front bearing

1. Measure the depth **(B)** of the countershaft front bearing bore in the transmission case and the countershaft front bearing height **(A)**.
2. The difference between the two measurements indicates the required thickness of the adjust shim.

$$\text{(A)} - \text{(B)} + \text{Adjust shim(s)} = 0.9 - 1.0 \text{ mm} \\ (0.035 - 0.039 \text{ in})$$

Standard installed bearing height: 0.9—1.0 mm (0.035—0.039 in)

Adjust shim thickness:

0.1 mm (0.004 in), 0.3 mm (0.012 in)

7A ASSEMBLY

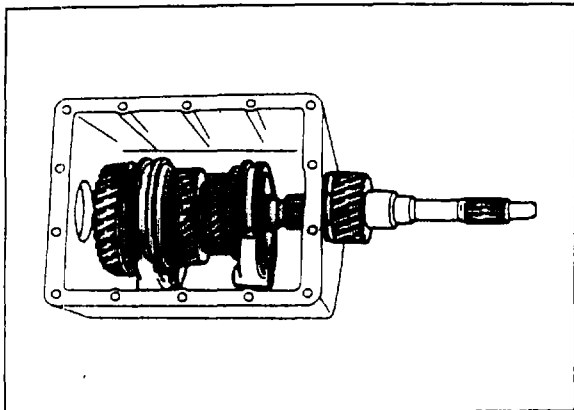

69G07A-113

Transmission Case

1. Position the 1st and 2nd shift forks and the 3rd and 4th shift forks in the grooves of the clutch hub and sleeve assemblies.
2. Install the needle bearing and main drive gear on the front of the mainshaft.

Note

Check that the friction gear engages the main drive gear.

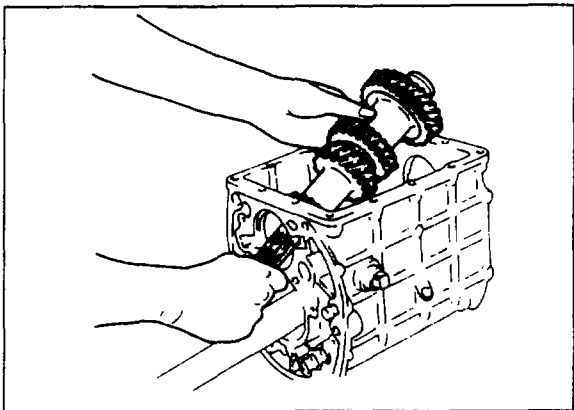

69G07A-114

3. Position the countershaft gear in the case, making sure that the countershaft gears engage each gear of the mainshaft assembly.

Note

Check that the friction gear engages the main drive gear.

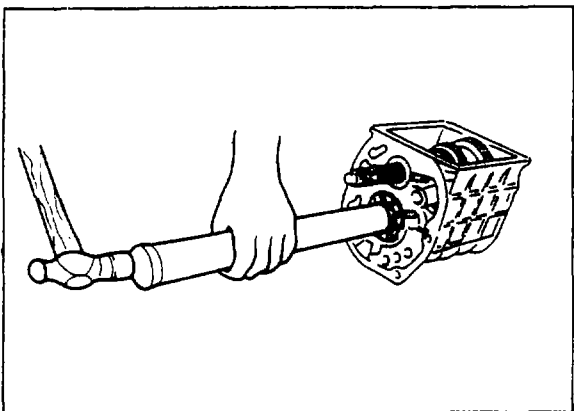

87U07A-008

Bearing for Transmission Case

1. Install the correct shim on the rear of the mainshaft as determined in the measurement of bearing thrust play.
2. Drive on the mainshaft bearing using a suitable pipe.

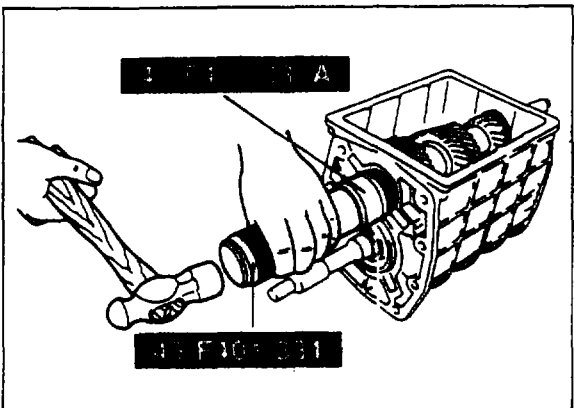

87U07A-009

3. Drive the countershaft center bearing onto the rear of the countershaft using **body** (49 F401 331) and **attachment A** (49 F401 335A).

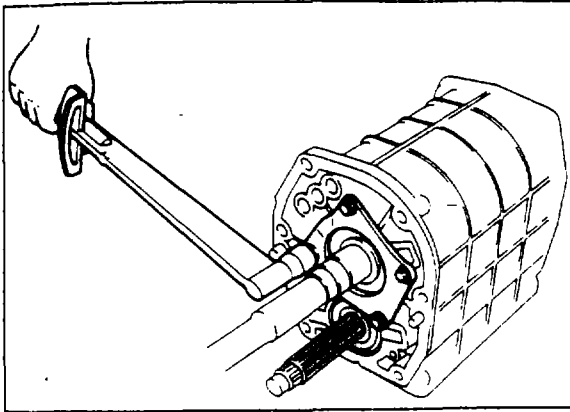

69G07A-117

4. Install the bearing cover.

Tightening torque:

18—26 N·m (1.8—2.7 m·kg, 13—20 ft·lb)

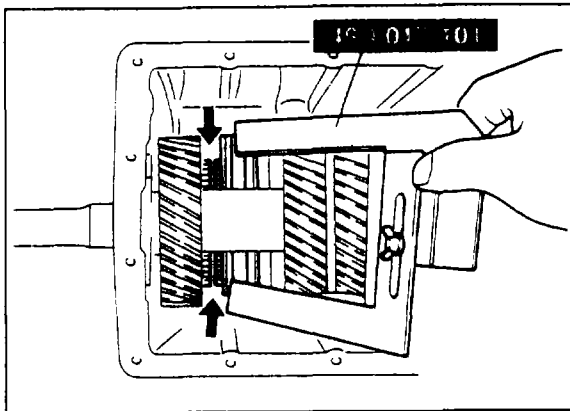

87U07A-010

5. Install the **synchronizer ring holder** (49 F017 101) between the 4th synchronizer ring and synchromesh gear on the main drive gear.

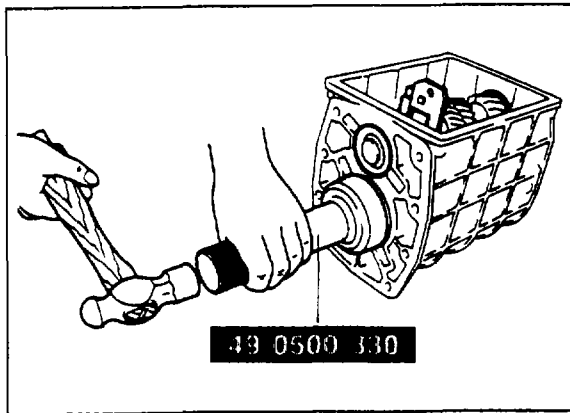

87U07A-011

6. Drive on the main drive gear bearing using **transmission bearing installer** (49 0500 330).

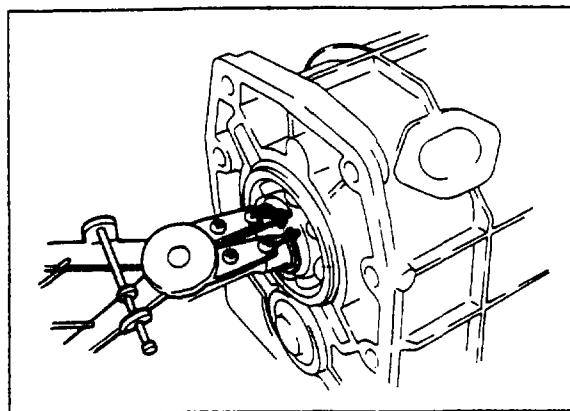

69G07A-120

7. Install the snap ring to secure the main drive gear bearing.

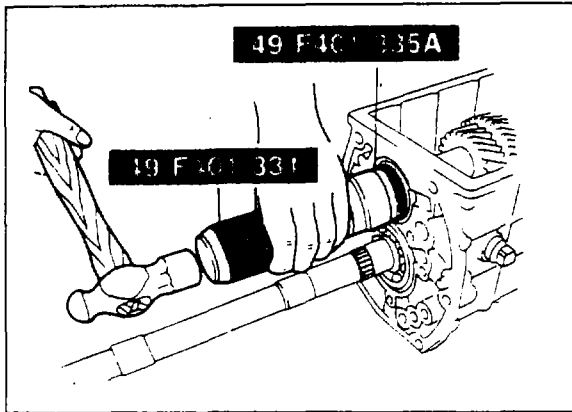

87U07A-012

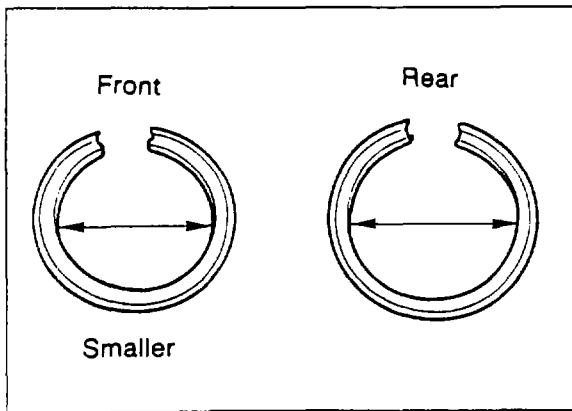

7BU07A-045

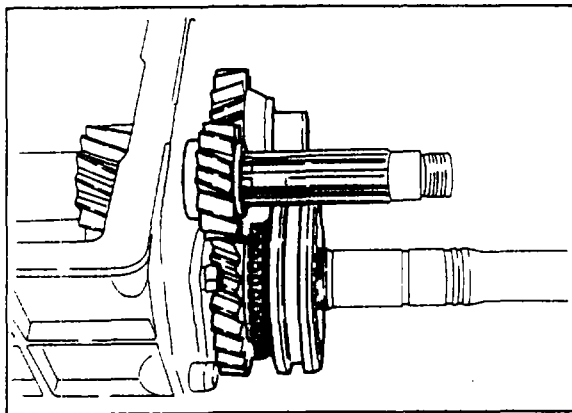

77U07A-070

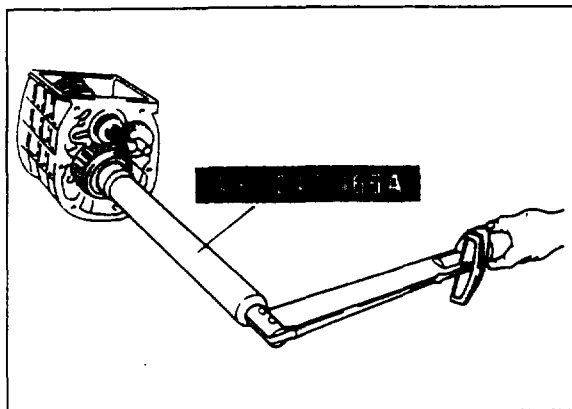

77U07A-071

8. Install the correct shim in the countershaft front bearing bore as determined by the measurement of bearing thrust play.
9. Drive on the countershaft front bearing using **body** (49 F401 331) and **attachment A** (49 F401 335A).

10. Install the snap ring to secure the countershaft front bearing.

Note

Do not confuse the front and rear bearing snap rings. The front snap ring is smaller.

Reverse Gear

1. Install the reverse idle gear and shaft with a spacer on each side of the gear.
2. Install the counter-reverse gear (chamfer side forward) and spacer.
3. Install the thrust washer, reverse gear, inner race, needle bearing, and clutch hub assembly.

4. Shift into 1st gear and reverse gear to lock the rotation of the mainshaft.
5. Install a new locknut and tighten it with the **main shaft locknut wrench** (49 1243 465A).

Tightening torque:

157—235 N-m (16—24 m-kg, 116—174 ft-lb)

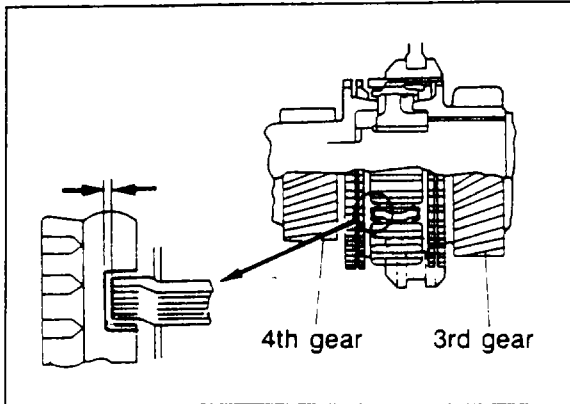

77U07A-127

6. Check the clearance between the synchronizer key and the exposed edge of the synchronizer ring. If the clearance is not within specification, select the thrust washer between the mainshaft center bearing and the first gear.

Standard: 0.66—2.0 mm (0.026—0.079 in)

Available thrust washer thickness:

**2.5 mm (0.098 in), 3.0 mm (0.118 in)
3.5 mm (0.138 in)**

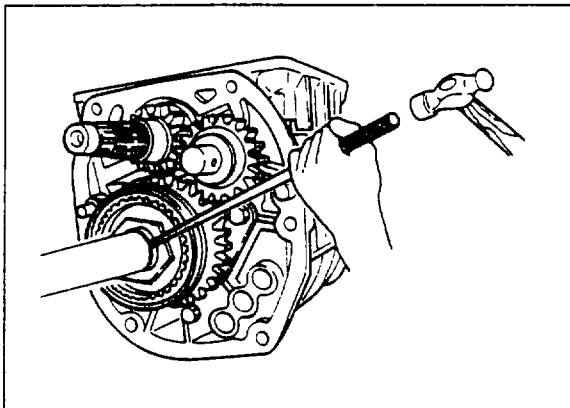

77U07A-073

7. Stake the lock nut into the main drive gear keyway.

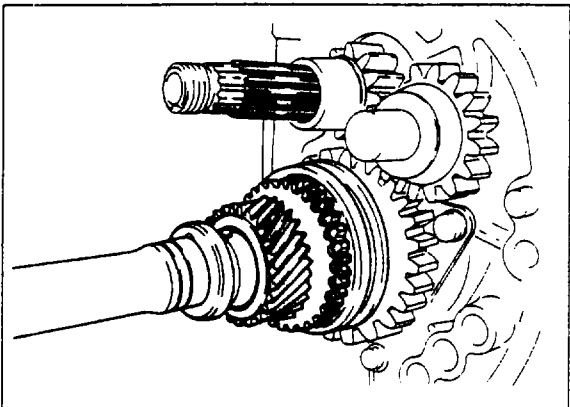

77U07A-074

5th Gear

1. Install the synchronizer ring and 5th gear.
2. Install the steel ball and thrust washer.
3. Install 3.0 mm (0.118 in) thick "C" washers and hold them with the retaining ring.

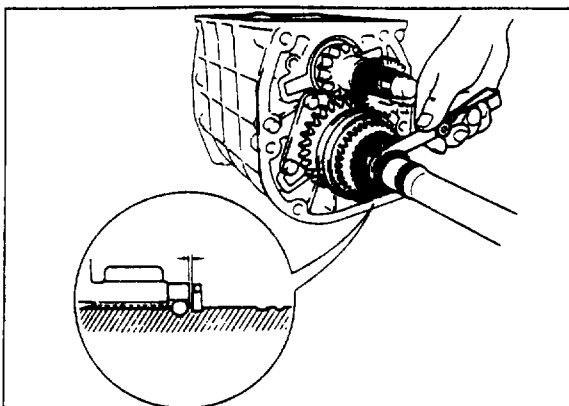

69G07A-126

4. Measure the clearance between the C washers and thrust washer. If it is not as specified, select another thrust washer.

Standard: 0.1—0.2 mm (0.004—0.008 in)

Available thrust washer thickness:

**6.4 mm (0.252 in), 6.5 mm (0.256 in)
6.6 mm (0.260 in), 6.7 mm (0.264 in)**

7A ASSEMBLY

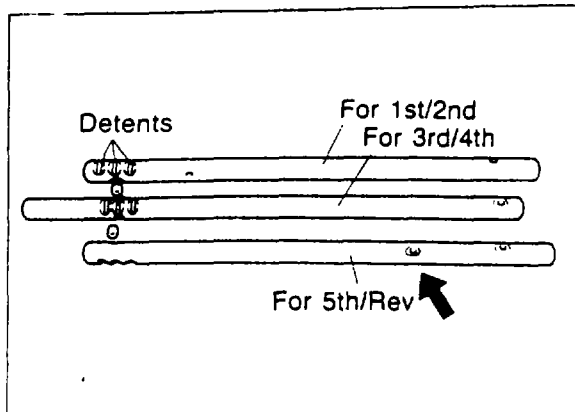

69G07A-127

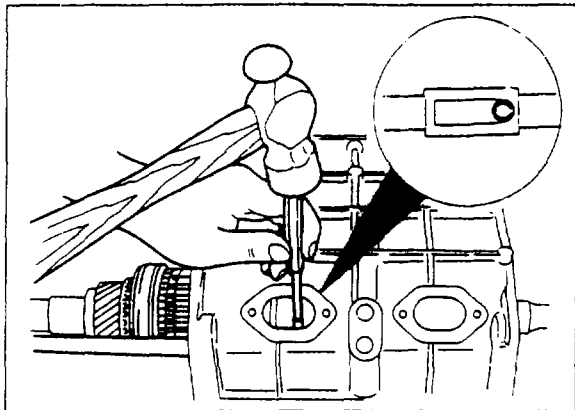

77U07A-076

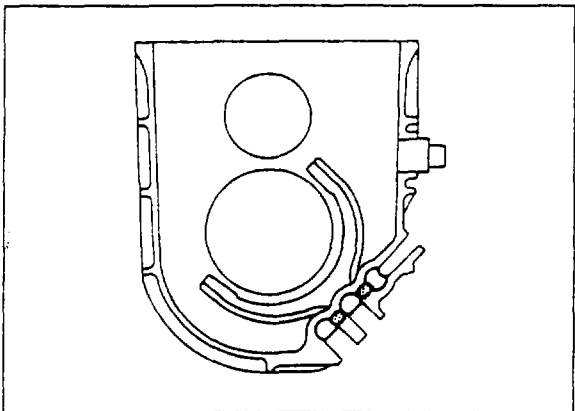

77U07A-077

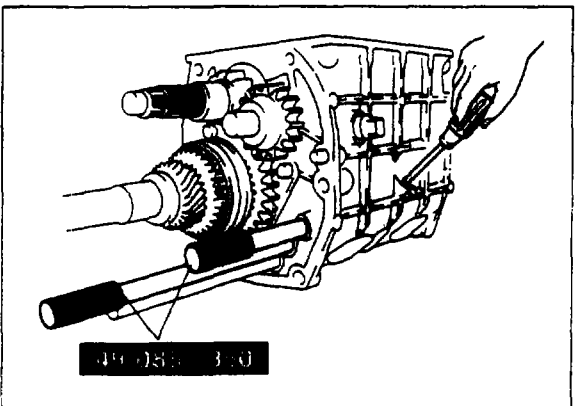

77U07A-078

Shift Fork and Rod

Note

A simple way to identify the shift rods is the following:

- The 3rd/4th shift rod is the longest.
- The 5th/Rev shift rod has an extra hole for the shift fork at the rear of the rod.

When installing the shift rods, set the detents toward the ball side.

Shift Fork and Rod

1. Slide the 1st and 2nd shift rod into the case.
2. Secure the 1st and 2nd shift forks to the rod with the spring pin.

Caution

The spring pin should be installed so the groove of the pin is as shown in the figure.

Note

Insert the interlock pin into the transmission case correctly.

3. Slide the **shift fork guide** (49 0862 350) into the transmission case, insert the inter-lock pin using **interlock pin guide** (49 0187 451A).
4. Slide the 3rd and 4th shift rod into the transmission case.
5. Secure the 3rd and 4th shift rod to the fork with spring pin.
Insert the interlock pin.

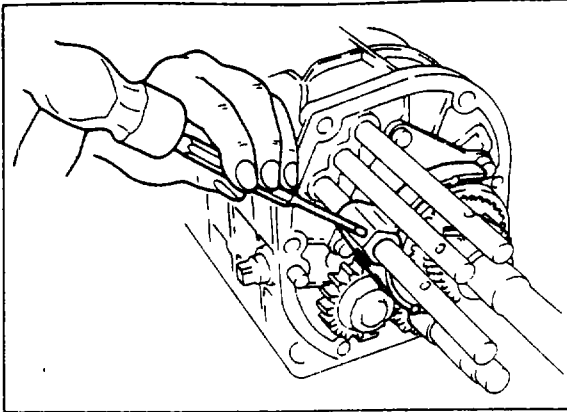

77U07A-079

6. Install the reverse and 5th fork on the clutch hub and slide the reverse and 5th shift rod into the transmission case.
7. Secure the reverse and 5th shift fork to the shift rod with the spring pin.

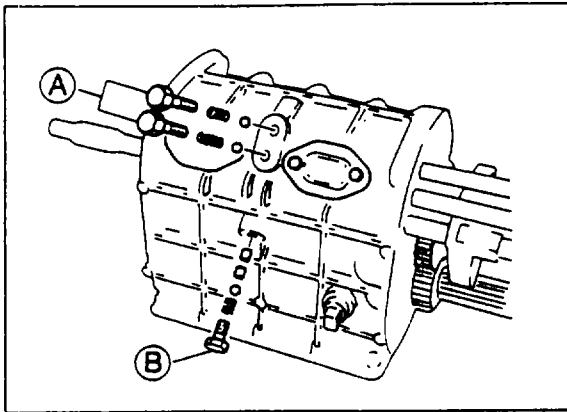

77U07A-080

8. Install the two blind covers and gaskets.

**Tightening torque: 7.8—11.8 N·m
(0.8—1.2 m·kg, 5.8—8.7 ft·lb)**

9. Install the three detent balls, springs and cap bolts.

Tightening torque:

A. 39—59 N·m (4.0—6.0 m·kg, 29—43 ft·lb)

B. 19—26 N·m (1.9—2.7 m·kg, 14—20 ft·lb)

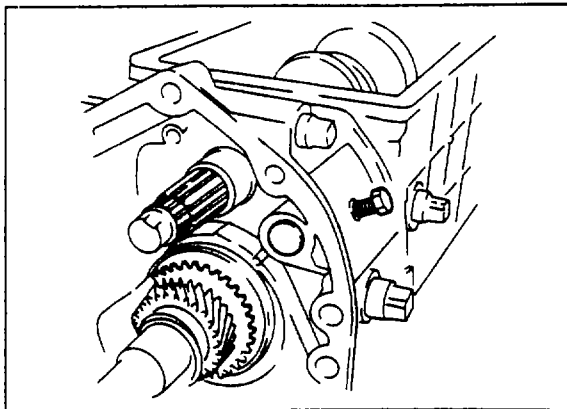

77U07A-081

Center Housing

1. Coat the contact surfaces of the transmission case and center housing with sealant.
2. Install the center housing.
Align the reverse idle gear shaft boss with the center housing attaching bolt boss, and tighten the bolt.

**Tightening torque: 8.8—13.7 N·m
(0.9—1.4 m·kg, 6.5—10.1 ft·lb)**

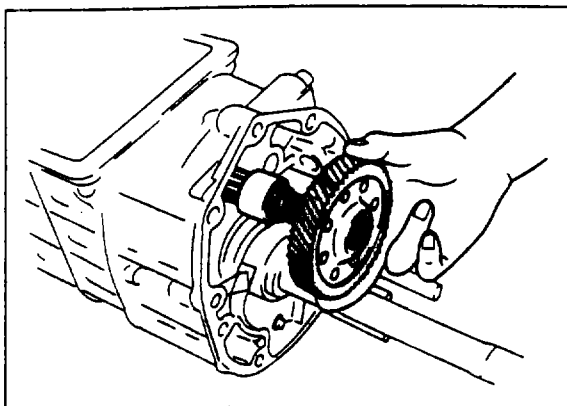

77U07A-101

3. Install the spacer and counter 5th gear.

7A ASSEMBLY

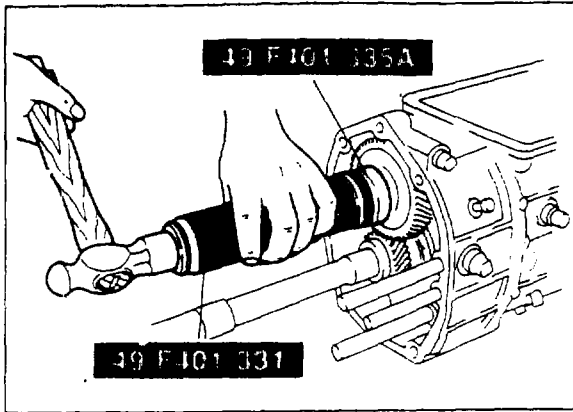

77U07A-082

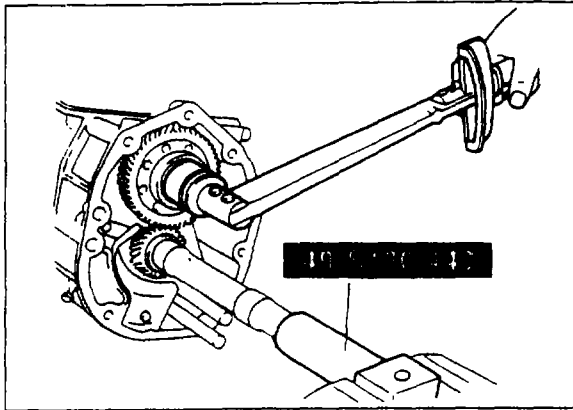

77U07A-083

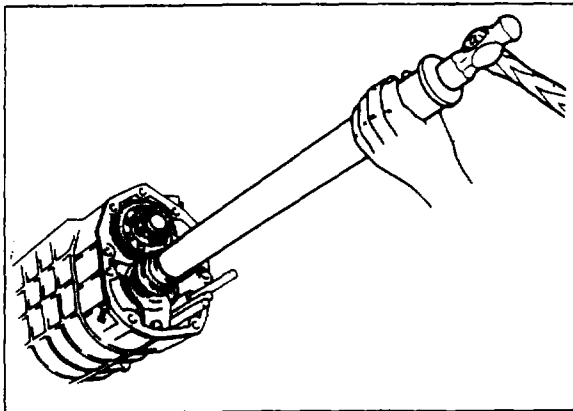

77U07A-084

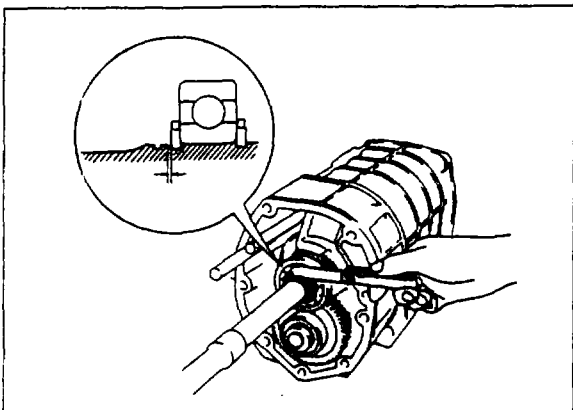

77U07A-085

Rear Bearing

1. Drive on the countershaft rear bearing using **body** (49 F401 331) and **attachment A** (49 F401 335A).

2. Shift into 1st gear and reverse gear to lock the rotation of the countershaft.
3. Install the countershaft lock nut.

Tightening torque:

127—196 N·m (13—20 m·kg, 94—145 ft·lb)

4. Stake the lock nut into the countershaft keyway.

5. Drive on the mainshaft rear bearing using a suitable pipe.

6. Install the "C" washers and hold them with the retaining ring.

7. Measure the clearance between the "C" washers and groove.

If the clearance is not within specification, select the proper "C" washers.

Standard: 0—0.1 mm (0—0.0039 in)

Available "C" washers thickness:

2.9 mm (0.1142 in), 3.0 mm (0.1181 in)

3.1 mm (0.1220 in), 3.2 mm (0.1260 in)

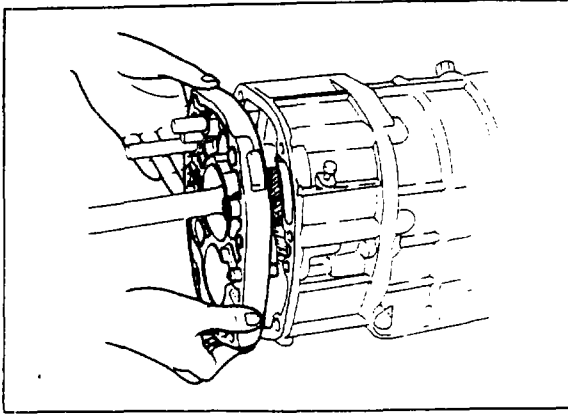

77U07A-086

Bearing Housing

1. Coat the contacting surfaces of the center housing and bearing housing with sealant.
2. Install the bearing housing on the center housing.

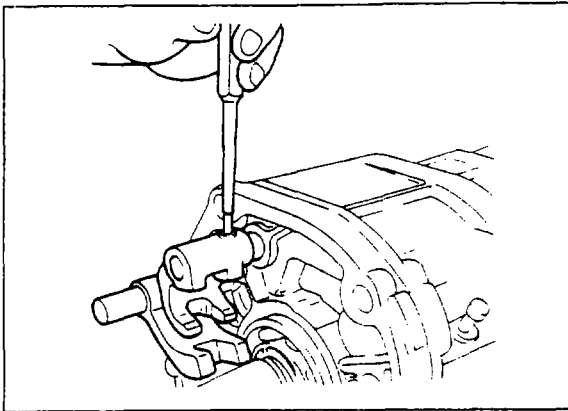

77U07A-087

Shift Rod End

- Install the shift rod ends onto the proper shift rods, and secure with spring pins.

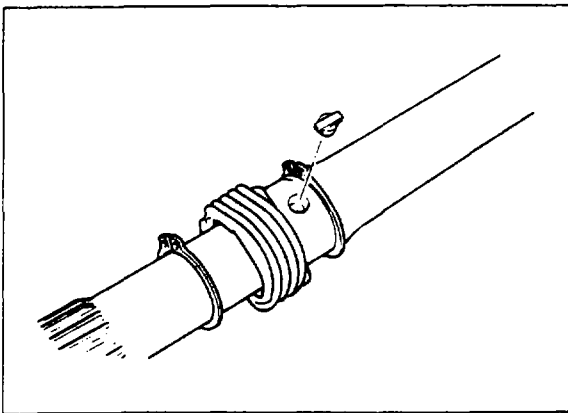

77U07A-088

Speedometer Drive Gear

1. Install the snap ring and key.
2. Install the speedometer drive gear and snap ring.

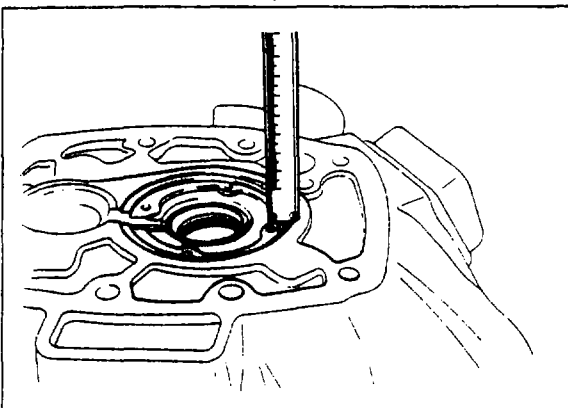

87U07A-013

Measurement of Bearing Thrust Play Main drive gear bearing

1. Measure the depth of the main drive gear bearing bore in the clutch housing using vernier calipers.

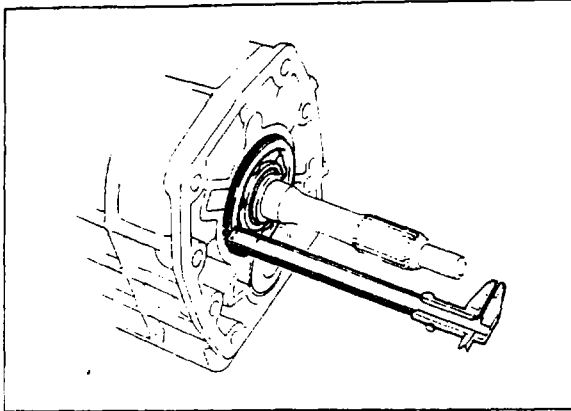

77U07A-124

2. Measure the main drive gear bearing height. The difference between the two measurements indicates the required thickness of the adjust shim.

Standard thrust play:

0—0.1 mm (0—0.004 in)

Adjust shim thickness:

0.1 mm (0.004 in), 0.3 mm (0.012 in)

Note

Make this measurement after assembling the transmission case.

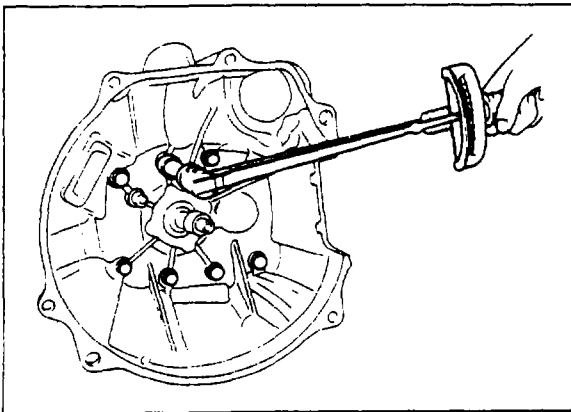

87U07A-014

Clutch Housing

1. Coat the contact surfaces of the clutch housing and center housing with sealant.
2. Install the correct shim on the main drive gear bearing and countershaft front bearing as determined in the Measurement of Thrust Play.
3. Tighten the bolts.

Tightening torque:

31—46 N·m (3.2—4.7 m·kg, 23—34 ft·lb)

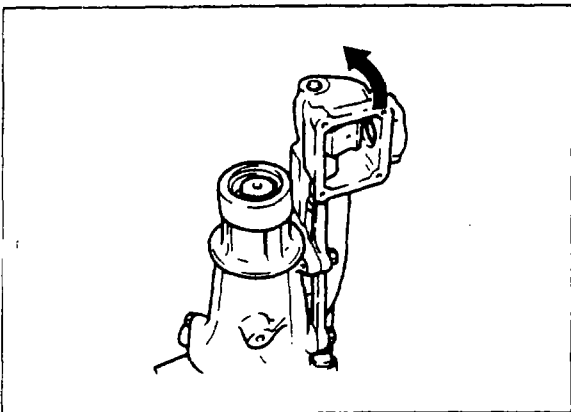

77U07A-090

Extension Housing

1. Coat the contact surfaces of the extension housing and bearing housing with sealant.
2. Turn the control rod in the direction of the arrow and install the extension housing.
3. Tighten the bolts.

Tightening torque:

31—46 N·m (3.2—4.7 m·kg, 23—34 ft·lb)

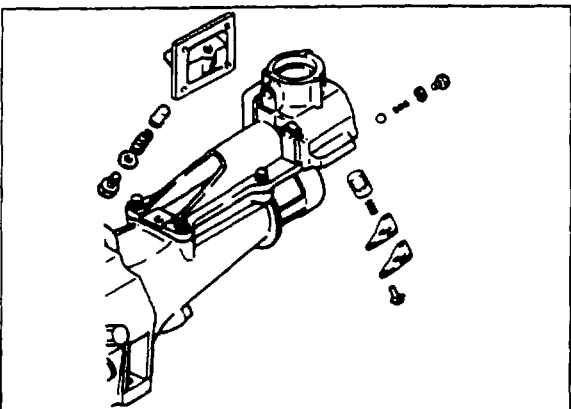

77U07A-128

Select Lock Spindle

1. Install the select lock spindle, spring and spring cap.
2. Push the select lock spindle down by pushing on the control rod. Insert the ball and spring and install the spring cap.

Note

If the select lock spindle is not pushed down, the ball will not correctly engage the select lock spindle.

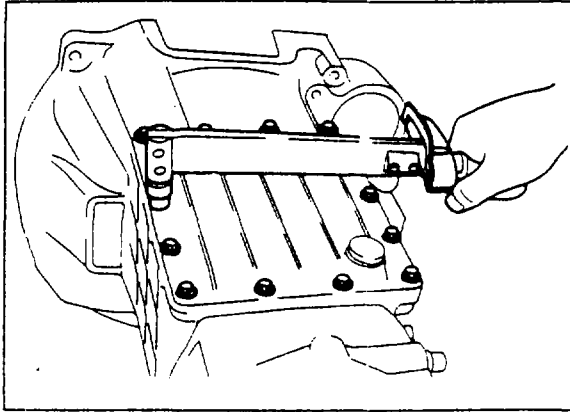

77U07A-091

Under Cover

Install the gasket and under cover.

Tightening torque:

6—9 N·m (0.6—0.9 m·kg, 4—7 ft·lb)

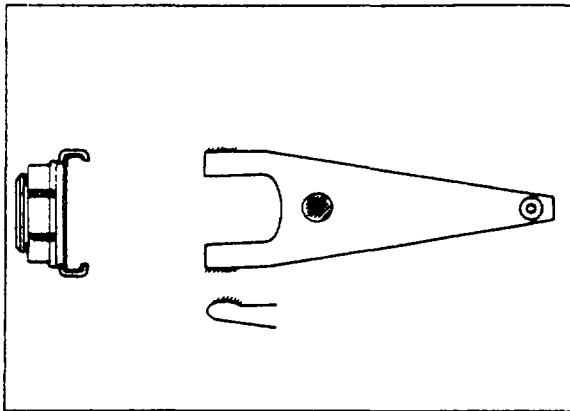

77U07A-092

Release Fork

1. Apply a coat of molybdenum disulphide grease to the parts of the release bearing and release fork indicated by the shaded lines in the figure.
2. Install the release bearing and release fork.

INSTALLATION

Install the transmission in the reverse order of removal.

Note

Fill the transmission with the correct grade and quantity of lubricant.